



Caravan Owners Manual

October 2020



ALICANTO
GRANDE



PEGASUS
GRANDE SE



UNICORN
BLACK EDITION



PHOENIX+



DISCOVERY



**360°
on-the-spot
manoeuvring**

5 YEAR WARRANTY
AL-KO Guarantee

**REIFER MARKEN
2016
5 PLATZ**

AL-KO

THE NEW AL-KO RANGER

EASY AND PRECISE MANOEUVRING AT THE TOUCH OF A BUTTON FOR SINGLE AXLE CARAVANS. AL-KO RANGER, QUALITY AND SAFETY AT AN AFFORDABLE PRICE.



The new manoeuvring system from AL-KO provides effortless control and simple operation to assist you in moving your caravan to exactly where you want it. On shale, tarmac or grass, Ranger takes the struggle away, leaving you to enjoy your holiday.

- | AL-KO Quality For Life Design
- | Suitable for almost any single axle caravan up to 1800kg
- | 360 degree on the spot manoeuvring
- | Manual Motor Engagement
- | Maximum Climbing Power - up to 18% incline
- | Soft Start and Soft Stop
- | Under Chassis Fitment
- | Remote Control
- | Protected Mechanics
- | 5 Year Warranty*

Ask for AL-KO Ranger at your local dealer or mover fitment company.

For more information:

ranger@al-ko.co.uk | 01926 818500 | www.al-ko.co.uk

*According to AL-KO Warranty Terms

AL-KO
QUALITY FOR LIFE

Pioneer Camper Navigation System

Easy, safe and smart navigation and entertainment, designed especially for camper vans

Stay on track with the Pioneer navigation, tailored for your Baileys motorhome, it'll take into account the vehicle dimensions when its planning your route, so you never get stuck. You'll be kept up to date with traffic reports to keep you out of jams, and you'll be able to search through millions of preloaded interest points, to find the nearest campsites.

- Motorhome navigation
- 45 Country EU Maps
- 10 million POI's
- Thousands of UK/EU campsites
- TMC traffic alerts
- Route / itinerary planner

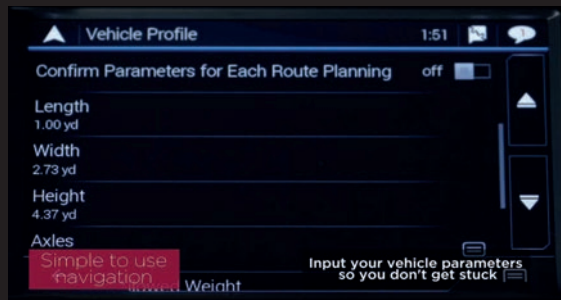

Navigation aside, you can enjoy a feature packed media hub.

- Bluetooth handsfree/ Audio
- FM/DAB+ radio
- CD/DVD Player
- Apple CarPlay
- Dual USB (audio/video)
- iPod/iPhone



Free glossy monthly magazine

50% off selected sites mid-week and more



Fantastic ferry fares

The Caravan and Motorhome Club There's no better value in touring



Save each night on pitch fees



Enjoy access to over 200 UK sites and 2,500 certificated locations



FREE technical help & advice

Discover our many sites on historic estates like Longleat



Exclusive member offers including M6 toll savings



Club Together our online community chat, interact, ask, review

Discover an unrivalled choice of sites and thousands of exclusive destinations, huge savings on everything from new cars and great days out to restaurant meals and show tickets plus a whole host of exclusive services and tailored insurance products.



What are you waiting for? Join today
www.caravanclub.co.uk or call 01342 318 813

Model: _____

Vehicle Identification number V.I.N: _____
(Located on the exterior windows and chassis)

Owner's name: _____

Address: _____

Telephone number: _____

Habitation key number: _____

Retailer's name: _____

Retailer's address: _____

Telephone Number: _____

MTPLM: _____

Caravan Height: _____

Caravan Length: _____

GREAT

GUIDES

TO THE

GREAT OUTDOORS

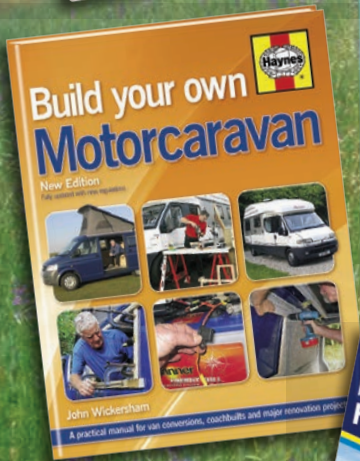
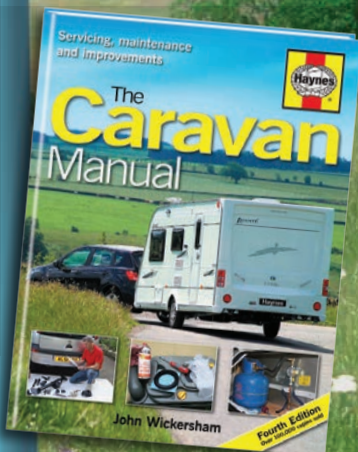

The Motorcaravan Manual
(3rd Edition)
ISBN: 978 0 85733 124 3
£22.99

Build Your Own Motorcaravan
(2nd Edition)
ISBN: 978 0 85733 281 3
£22.99

The Caravan Manual
ISBN: 978 1 84425 678 5
£22.99

Driving Abroad
ISBN: 978 1 84425 576 4
£12.99

Motorcaravanning Handbook
(2nd Edition)
ISBN: 978 0 8 5733 264 6
£14.99

Prices correct at the time
of printing



Follow us on:



www.haynes.co.uk

Books for enthusiasts
by enthusiasts



Available from all good bookshops or ORDER DIRECT on Tel: 01963 442030

CONTENTS

INTRODUCTION

Introduction	1
Driving Licences	2

STATEMENT OF CONFORMITY

Statement of Conformity	2
-------------------------	---

WARRANTY

Touring Caravan Warranty Cover	3
6 Year Bodyshell Integrity Warranty	3
Warranty Extension	3
3 Year Manufacturer's Warranty	3
Warranty Extension	4
Customer Support	4
Terms and Conditions	4
Cover	4
Term	4
Repairs	4
Registration and Use	5
Exclusions and Liability	5
Warranty Registration	6

CENTRAL REGISTRATION AND IDENTIFICATION SCHEME (CRiS)

CRiS Registrations:	7
---------------------	---

COUNTRY AND COASTAL CODE

Code of Conduct	8
Arrivals	8
Vehicle Movement	8
Use of Site	8
Cautions	8
Noise	8
Dogs and Pets	8
Fire Precautions	8
Awnings and Tents	8
Departure	8
Handbook	9
Environment	9
The Country Code	9
The Coastal Code	9
Roof Loading	9
Safety and Security	9
Children	9
Fire Extinguishers	10
In Case of Fire	10
Ventilation and Condensation	10
Petrol and Diesel Fumes	10
Original Equipment Appliances	10
Portable Appliances	10
Modifications	10

CARAVAN AND TOW VEHICLE

Caravan and Towing Vehicle Terms	11
Kerb Weight of Towing Vehicle	11
Caravan to Towing Vehicle Weight Ratio	12
Towing Vehicle's Rear Suspension	12
Recommended Towball Height	12
Secondary Braking Cable	12
Loading and Distribution of Weight	13
Hitching Up	14
Hitching the Caravan to the Tow Vehicle	14

TOWING

Speed Limits	16
Pulling Away	16
Caravan Handling	16
Reversing	16
Motorway Driving	16
Mirrors	16
Snaking	16
Stabilisers	17
Road Lighting	17
13 Pin Plug	17

UNHITCHING

Levelling the Caravan	19
-----------------------	----

WHEELS AND TYRES

Tyres	20
Wear and Damage	20
Wheel, Tyre and Bolt Safety Fitment	20
Tyre Pressures	20
Wheels	21
Spare wheel	21

SPARE WHEEL CARRIER

To lower the Spare Wheel	21
Returning the Spare Wheel	22
TPMS Tyre Pressure Monitoring	22

THE AL-KO CARAVAN CHASSIS (AKS 3004)

Operating Instructions	26
Coupling	26
Stabiliser Unit	27
Uncoupling	27
Manoeuvring Operation	28
Noises While Driving	28
Remedial Action	28
Storing	28
Towing Ball	28
Overrunning Device	29
Jockey Wheel	29
Brake Linkage	29
Corner Steadies	29

Braking System Adjustment	29
Chassis Lubrication Points	31
AL-KO ATC Trailer Control System	31
Operating Instructions	31
Spare Parts	31
Independent Suspension	32
Coupling Head	32

TRACKER MONITOR

Operating Instructions	33
General Questions	33

WATER SYSTEMS: WITHOUT AN ON-BOARD WATER TANK

Water Supply	35
Drain Valve	35
Setup	35
Removing the Plug	36

WATER SYSTEMS: WITH AN ON-BOARD WATER TANK

Water Supply	37
Filling the On-board Tank	37
Internal Supply	37
Tank Drain Operation	38
Draining and Winterization	38
Procedure	38
Initial Setup	38
Sterilising	38
Water System Troubleshooting	39
Adjusting your Pressure Switch	40

THE GAS SYSTEM

General information	42
Types of gas	42
The Regulator	42
Changing Gas Cylinder	43
Gas Safety Advice	43
Gas Leaks	43
Ventilation	44
Gas BBQ Point	44

THE ELECTRICAL SYSTEM-230v

Instructions for Electricity Supply	45
Upon Arrival at Caravan Site	45
Upon Leaving Caravan Site	45
Overseas Connections	45
Mains Unit	45

THE ELECTRICAL SYSTEM- 12v

Battery Box Connections	47
-------------------------	----

CONTROL PANELS

CBE Control Panels	49
--------------------	----

STATUS 570 ANTENNA

Travelling	53
Operating	53
DAB and FM Radio Operation	53
Gain Control	53
LED Light	53
Short Hook Up: Test 1	53
Short Hook Up: Test 2	54
Antenna Dome Coaxial Cable	54

SOLAR DUAL BATTERY CHARGER SDC 10/20

Operating Instructions	55
Function	55
Charging Process	55
Bulk Phase	56
Absorption Phase	56
Float Phase	56
Parallel Mode	56
Settings	56
Battery Type	56
Charging Current Distribution	56
PWM Charging Frequency	57
Query	57
Function Display / Troubleshooting	57
Repairs	57

HEATING SYSTEMS (ALDE)

Operating Instructions	58
Description of Functions	58
Gas Heating	58
Electric Heating	58
Domestic Hot Water	58
Draining Freshwater	59
Heat Transfer Fluid	60
Filling	60
Central Heating	61
Circulation Pump	61
Bleeding Air	61
Air Lock	62
230v Electric	62
LPG	62
Flue	63
Maintenance	63
Winter	64
Troubleshooting	64
Warranty	65

ALDE CONTROL PANEL

Starting the System	66
Standby Screen	66

Main Menu	67
Desired Room Temperature	67
Domestic Hot Water	68
Electric Heating	69
Gas Heating	69
Shutting Down the System	70
Setup	70
Restore Default Factory Settings	70
Setup Expansion Tank Pump	70
Set up Antimicrobial Function	70
Setup Standby Screen for Bedtime	70
Maintenance	70
Troubleshooting	70
Battery Backup	71

TRUMA COMBI

COMBI E Series	72
Function Description	72
Heating and Hot Water Mode	72
Hot Water Mode (Filled Boiler)	73
Operating Instructions	73
Room Thermostat	73
Filling the Water Heater	73
Draining the Water Heater	73
Filling the Water Heater (Frost Control)	74
Draining Water Heater (Frost Control)	74
Start Up	74
Switching Off	74
Maintenance	74
Fuse 12v	76
Fuse 230v	76

TRUMA DIGITAL CONTROL PANEL

Safety Instructions	77
Display and Control Elements	77
Rotary Push Button	77
Start/Standby Screen	78
Functions	78
Change the Room Temperature	78
Select Energy Source	79
Select Fan Level	79
Set the Room Temperature	79
Set the Warm Water Level	79
Select Energy Source	79
Select Fan Level	79
Set the Timer Switch	79
Activate the Timer (ON)	80
Deactivate the Timer (OFF)	80
Set Time	81
Display Mains Voltage 230v	81
Warnings	81

EXTERIOR FEATURES

GRP	82
-----	----

ROOFLIGHTS

HEKI Rooflights	82
Safety instructions	83
Care instructions	83
MPK Rooflight	83

COOKING EQUIPMENT

Operation	85
Using the Hotplate Gas Burners	85
Using the Electric Hotplate	86
Using the Grill	86
Using the Oven	87
Oven Temperature Control	87
Cooking Guidelines	87
Do's and Don'ts	88
Maintenance and Servicing	88
Service	88

DAEWOO MICROWAVE OVEN

Features	90
Operation Procedure	91
Wattage Output	91
Controls	91
Setting the Clock	92
Weight Defrosting	92
Time Defrosting	92
Cooking in One Stage	92
Cooking in Two Stages	92
Easy Cooking	92
Auto Cook	93
Child Safety Lock	93
Microwave Specifications	93

RUSSELL HOBBS MICROWAVE

Features and Information	94
Control Panel	96
Clock Setting	97
Speedy Cooking	97
Defrosting	97
Multi Stage Cooking	97
Auto Menu	98
Checking Functions	98
Cleaning	99
Guarantee	100

CARBON MONOXIDE ALARM

Features	101
Testing	101
Testing the Sensor	101
Maintaining/Testing Your Detector	102

BATHROOM CARE

Bathroom Shower Tap	103
Mirrors	103
Ecocamel Shower Head	103

THETFORD C262 TOILET

Parts	104
Using The Toilet (Standard)	104
Cleaning and Maintenance	104
Toilet Bowl	104
Waste Holding Tank	105
Winter Operation	105
Preparing the Waste Holding Tank	106
Emptying the Waste Holding Tank	106

REFRIGERATORS

Cleaning	107
Maintenance	107
Lighting	107
Parking Lock	107
Exchanging the Igniter's Battery	107
Safety Instructions	108
User's Responsibility	108
Information on Coolant	108
Appliances with Electronics (MES/AES)	108
Operating the Refrigerator with Gas	108
Electrical Operation	110
Mains power 230v	110
Gas Operation	110

RML9330/RM8550/RMS8550/RM8500

Operation	111
Troubleshooting	115

RMD8551

Operation	111
Troubleshooting	115

STAINLESS STEEL SINK

Care	118
------	-----

SMOKE ALARM

Features	118
Simple Maintenance	118

SOFT FURNISHINGS

Carpet	121
Upholstery	121
Cleaning and Care	121
Winterisation and Storage	121
Curtains	121

REMIS BLINDS

Remibase	121
Cleaning	121
Remi Flair	122
Function	122
Maintenance	122

GENERAL CARE AND MAINTENANCE OF YOUR CARAVAN

Exterior	123
Cleaning/Usage Information	123

GENERAL CARE

Acrylic Windows	123
Window Catches and Stays	124
Humidity	124
About Condensation	124
How to Keep Your Caravan Dry	124
Furniture	124

WINTERISATION & STORAGE

Procedure	125
-----------	-----

MODIFICATIONS & DIY WORK

Warning	125
---------	-----

CARAVAN KEYS

Information	125
-------------	-----

SPARES & AFTERSALES

Accessories	125
-------------	-----

BED MAKE UP

Front Bed Make Up	126
Rear Fixed Bed Extension	127
Rear Dinette Bed Make Up	128
Grande Dinette Make up	129
Retractable Rear Bed	130
Additional Fold Out Rear Bed	130
Free Standing Table	131

THE SERVICE MANUAL

©BAILEY OF BRISTOL 2018. ALL RIGHTS RESERVED

No part of this document may be reproduced or transmitted in any form or by any means, electronic or mechanical, for any purpose, without the express permission of Bailey of Bristol Ltd.

INTRODUCTION

Congratulations on the purchase of your Bailey caravan. We would like to welcome you to the prestigious rank of Bailey owner. We are confident your caravan will give you many years of enjoyment.

This handbook has been designed to assist you in obtaining the maximum benefits and pleasure from your caravan. The information and hints will be beneficial and help you protect your investment, whether you are a new or experienced caravan owner.

Information leaflets and literature on safe operation of appliances and equipment fitted to your caravan are included in the Bailey information pack. Please read these carefully prior to the use of these appliances.

This manual covers the essential parts of your caravan, however it is not exhaustive. Detailed information can be obtained from individual manufacturers regarding their products.

Failure to observe recommendations or precautions within this or any other related documentation may lead to incorrect operation of equipment. This may cause subsequent risk to occupants.

Regular maintenance is necessary to ensure trouble-free usage of your caravan. Your Bailey retailer is equipped to offer service facilities, repair work and any spare parts that you may require.

Always consult your supplying retailer before any additional equipment is fitted. This is to ensure the location of appropriate structural support.

Retailers are not agents of Bailey and have absolutely no authority to bind Bailey by any express or implied undertaking or representation.

Please be aware that certain sections are only applicable to certain models.

In order to enable Bailey and its retail partners to deal with your queries efficiently, always quote your caravan's vehicle identification number (VIN) which can be found on the offside chassis member. It is also featured on all major windows.

It is policy within Bailey to continuously improve their vehicles. While all illustration and descriptive material within this handbook is correct at the time of going to print, the ever changing market and supply situations may prevent us from maintaining the exact specification details of this handbook. Bailey therefore reserve the right to alter the specification of its products at any time without prior notice.

Bailey offer a variety of leisure vehicles. While each vehicle is designed to feature optimum storage, seating, sleeping and fluid capacities, it is the customer's responsibility to select the correct loads without exceeding the weight capabilities of your chosen towing vehicle. These weights can be found on the weight plate located outside your vehicle next to the exterior door and also on the plate found within the gas locker.

SAFETY

This handbook contains the information that you will require for your safe enjoyment of your caravan. All the information contained within is important. However, to draw your attention to specific items we have prefixed them with the following symbols to indicate a warning, caution or note respectively.



WARNINGS are instructions that if ignored can cause the user(s) physical harm.



CAUTIONS are instructions that if ignored can result in damage to the caravan.



NOTES are reminders that should be heeded.

IMPORTANT SAFETY NOTES



To ensure all the occupants of your caravan enjoy a safe and relaxed environment, please observe the following:

- Ensure all the occupants are aware of the vehicle's escape routes.
- Always keep escape routes and exit points clear from obstruction and debris.
- Provide one dry powder fire extinguisher of an approved type or complying with ISO 7465 and BSI 5423 of at least 1kg (2.2lb) capacity by the main door, and a fire blanket next to the cooker. Familiarise yourself with your fire extinguisher.

Your tourer is a compact living environment, and appliances should be treated in the same way as those in the home.

- Always keep young children away from hot surfaces.

Your tourer is supplied with an EN1645 approved caravan step. Always take care when entering or exiting your tourer ensuring that the step is securely located before use. Do not use a damaged or broken step.

- The torque setting of the caravan's wheel bolts should be checked 30 miles after collection from the caravan retailer. Thereafter, wheel bolts should be checked before every journey. The torque settings and tightening sequence are detailed in the caravan and tow vehicle section.
- Never attempt to lift the tow hitch with your hands when hitching the caravan to the tow vehicle or at any other time. Always raise or lower the tow hitch by winding the handle on the jockey wheel.
- Always ensure that the green button located on the leading edge of the coupling head is raised before towing. (Coupling specific).

STATEMENT OF CONFORMITY



All Bailey caravans have been certified by the National Caravan Council for compliance with UK and European standards and legislation along with industry codes of practice relating to health and safety issues. The approval process covers the testing and inspection of critical areas of the product including fire safety, weights and dimensions, gas, electrics and ventilation. Every Bailey caravan carries the NCC Approved Caravan badge. The NCC conducts unannounced inspections at their members' factories to ensure continued compliance.

NCC approval gives you peace of mind that your caravan is safe and legal.

Your Bailey caravan is also European Whole Vehicle Type approved. This certification assures you that your caravan meets all European regulations and has been constructed to conform to the rigorous standards for both manufacturing and product safety. It enables you to register your vehicle in other European countries.

The certificate of conformity can be found in the document pack provided with your vehicle.

If for any reason a replacement certificate should be needed your Bailey Caravan retailer is responsible for accessing one through the NCC system.

Please refer back to your retailer for additional copies.

DRIVING LICENCES

Drivers passing their test after 1st January 1997 are restricted to a car/caravan combination not exceeding 3,500kg (maximum laden weight). New drivers outside these rules will need to take an additional driving test.

WARRANTY

If you have a problem or enquiry relating to your caravan please follow these steps:

- Check the handbook concerned
- Contact your supplying retailer for assistance.

The following suppliers provide a direct aftersales service.

AL-KO

AL-KO Kober Limited
 South Warwickshire Business Park
 Kineton Road
 Southam
 Warwickshire
 CV47 0AL
 Fax: 0044 (0)1926 818562
 E-Mail: mail@al-ko.co.uk

DOMETIC

Dometic UK Ltd
 Dometic House
 The Brewery
 Blandford St Mary
 Dorset
 DT11 9LS
 Telephone: 0044(0)844 626 0130
 E-mail: technical@dometic.co.uk



It is with the retailer that the purchaser's Contract of Sale exists and subsequently Bailey cannot enter into any discussions with the purchaser.

All Bailey products are classified as "portable". All work under warranty requires that the caravan be delivered to and collected from the Bailey retailer.

Every effort has been made within this handbook to accurately reflect and describe Bailey caravan models. Our policy of continued improvements and change in market and supply conditions mean that we reserve the right to alter specification without prior notice. Some materials used in the production of our caravans can result in variations to the figures quoted in respect of measurements and weights.

TOURING CARAVAN WARRANTY COVER

Total customer satisfaction is top priority at Bailey and the quality ethos extends to the after sales service and market leading manufacturer's warranty package that comes with every new Bailey touring caravan. In this way we not only ensure long-term peace of mind but also enhance the re-sale value of your investment.

6 YEAR BODYSHELL INTEGRITY WARRANTY

Bailey Alu-Tech caravans are covered by a six (6) year Bodyshell Integrity Warranty from the initial date of purchase. This cover extends to any structural degradation to the bodyshell that arises as a result of water ingress through any permanently sealed seam or joint (with the exception of exclusions stated in the terms and conditions).

WARRANTY EXTENSION

An additional four (4) year extension to the standard Bodyshell Integrity warranty cover (making 10 years cover in total) is available as a cost option. Please ask your supplying Bailey retailer for more information.

3 YEAR MANUFACTURER'S WARRANTY

For a period of twenty-four (24) months from the initial date of purchase Bailey of Bristol offer a comprehensive warranty on all parts and components as well as full coverage for any manufacturing faults forming part of the original specification of the vehicle, with the following specified exceptions:

The following items are covered for one (1) year from the date of first registration

- Microwave Ovens
- Pioneer Stereo Radio/CD/MP3 Players & Speakers

The manufacturer's warranty then extends to an additional twelve (12) months on the following items.

- Chassis: all chassis members including corner steadies
- Suspension: axle suspension and braking system (excluding any damage to or faults in brake drums and shoes that are caused through misuse of the braking system or from normal wear and tear)
- Running Gear: road wheels (excluding tyres)

- Towing Mechanism: all mechanical components fitted to vehicle (excluding electrics)
- Cooker: the cooker unit including burners, grill, oven, flame failure device and igniter
- Refrigerator: door seal condenser, gas control valve, gas igniter, flame failure device, 12v and 230v heater elements, gas thermostat, 230v thermostat and 230v temperature control switch
- Water System: water heater (gas or electric), fresh water tank, water pump, water, gauges, taps and shower head
- Electrical System: mains hook up input connector, ELCB, battery charger and distributor unit and interior lighting units (excluding bulbs)
- Cassette Toilet: the cassette toilet is covered (excluding seals, valves and glands)
- Heating System: thermostat, motor, switches, control unit, gas heater, flame failure device and igniter (excluding ducting and fittings)
- Windows: the functionality of the opening and closing system (stays, handles and catches) and a warranty against the cracking of the acrylic
- Upholstery: zips, seams and colour fastness

WARRANTY EXTENSION

An additional three (3) year extension to the standard Manufacturer's Warranty cover for mechanical and electrical components of a leisure vehicle both external and internal (making 6 years cover in total) is available as a cost option through your supplying Retailer. Customer Support

Approved Bailey Retailers enjoy industry-leading after sales support service from the manufacturer and they will be able to offer all the help you need to rectify any issues that may occur. They should be your first point of contact on any subject relating to your vehicle. It should be noted that Bailey Approved Retailers sell our products of their own choice and not as agents of Bailey. Accordingly, they have no authority to bind Bailey or make representation or undertaking whatsoever on behalf of Bailey.

TERMS AND CONDITIONS

The Bailey Warranty Cover set out above is offered subject to the following simple terms and conditions:

COVER

During the term of the Warranty Cover, subject to these terms and conditions, Bailey will, through an Authorised Service Centre, at its option repair or replace all parts and components of the caravan that are included in the Warranty Cover and which suffer a defect in manufacture or workmanship. An Authorised Service Centre means either Bailey itself, a Bailey Approved Retailer or a Bailey Approved Service Centre. Any part which is replaced becomes the property of Bailey. Any replacement parts are covered for the unexpired term of the Warranty Cover.

TERM

1. The initial duration of the Bodysell Integrity Warranty is six (6) years and the duration of the Manufacturer's Warranty is three (3) years in both cases starting from the original purchase date of the vehicle. It is a condition of the warranty that an annual service is performed on the vehicle in accordance with the service plan. Failure to comply with this term will invalidate the warranty.

2. The unexpired term of the Warranty Cover on your vehicle may only be assigned, transferred or novated to subsequent owners with Bailey's consent (not to be unreasonably withheld) and on payment to Bailey of a transfer fee of £35. Transfer can only be made within the first three months (3) of the date subsequent ownership was taken and full documentary evidence that the vehicle has been serviced annually along with evidence of the date of subsequent purchase (in the form of a VAT sales receipt, invoice or bank/credit card statement) must be provided at the time of assignment in accordance with the terms and conditions detailed above

REPAIRS

3. The caravan must undergo a full annual service and inspection, including a moisture survey, carried out, subject to paragraph 5 below, by an Authorised Bailey Service Centre or by a service agent that is a member of the National Caravan Council's Approved Workshop

Scheme (AWS).

4. The final annual service in any warranty period must be carried out before the end of that warranty period, but all other annual services may be carried out within six (6) weeks either side of each anniversary of the original purchase date. The original VAT invoices must be retained as proof that these annual inspections have been carried out.

5. Where an annual inspection identifies that repairs to the vehicle are necessary, the caravan must be made available for repair within six (6) weeks of the date of inspection for the purpose of carrying out the repair work. Repairs under warranty must be undertaken by either Bailey itself, a Bailey Approved Retailer or a Bailey Approved Service Centre.

6. No repairs, including the fitting of any replacement unit, may be undertaken or commenced under the terms of the Warranty Cover unless prior written authorisation is obtained from Bailey via a Bailey Approved Retailer or a Bailey Approved Service Centre. No liability will exist with regard to any warranty claims not authorised in this way.

7. Bailey reserve the right to examine the vehicle before any repairs commence or any replacement part is fitted.

REGISTRATION & USE

8. The Warranty Registration Form must have been sent to Bailey within six (6) weeks of the original purchase date. It is the responsibility of the Bailey Retailer to forward this information to Bailey. This is part of the terms of trading that the Bailey Retailer has with Bailey.

9. The caravan shall: Only be used for its ordinary and intended purpose and shall not be subjected to any

- Treatment or conditions which could reasonably be foreseen to cause or result in damage to the vehicle or excessive wear and tear
- Only be towed by a private car or private 4x4 vehicle
- Not be put out to hire, reward or any other commercial use, nor used in any race, competitions or rallies whether timed, official or otherwise.

EXCLUSIONS & LIABILITY

10. Bailey's liability under this warranty shall be limited to supplying the reasonable costs of labour and materials required for the repair or replacement of faulty parts or components. Bailey shall be entitled to charge for any repair work which is necessitated by virtue of any loss or damage caused by your negligence or default or incurred as a result of any modifications you have made to the vehicle. This warranty does not cover repair costs other than labour and materials.

11. The Warranty Cover does not include: • Repair or replacement of parts, components, seams or panels which are not part of the original construction of the caravan, or which have been tampered with or undergone unauthorised modifications, or which have been repaired otherwise than by An Approved Bailey Retailer or a Bailey Approved Service Centre.

- Parts or components other than those specifically listed in the Bodysell Integrity Warranty and Manufacturer's Warranty descriptions set out above
- General maintenance or components failing due to fair wear and tear or normal deterioration repairs necessitated by lack of routine or regular maintenance. Particular attention is drawn to the Owner's Manual and Service Handbook supplied with the caravan and any maintenance instructions or notices published from time to time by Bailey relating to the proper care and maintenance of vehicles
- Structural degradation or other damage caused by water ingress through non-permanently sealed seams or joints (such as, without limitation, around windows, hatches, doors and rooflights), beyond the initial 24 months of the Manufacturer's Warranty.

12. No liability will be accepted for: • Damage caused by neglect or abuse, corrosion, intrusion of foreign or deleterious substances, lack of servicing, over-heating, freezing, or the continued use of the vehicle after a fault has become evident

- Any loss or damage caused by parts not covered by this Warranty Cover, including soft furnishings or trim



- Any accidental or fire damage or any losses incurred by accident or fire
- Transport costs to and from point of repair.

Bailey will only be liable for costs which are incurred as a direct consequence of the event, defect or fault leading to the claim being made under this warranty. No liability will be accepted for any other loss or damage (such as loss of income or revenue, or loss of business or profits), costs, expenses or other claims for compensation howsoever arising which was not reasonably foreseeable by both parties when the caravan was originally purchased. Bailey will not be liable for any loss or damage suffered by third parties, nor for bodily injury not caused by our negligence.

Nothing in this warranty shall limit in any way our liability; for death or personal injury caused by our negligence; for fraud or fraudulent misrepresentation; or for any matter for which it would be illegal for us to exclude, or attempt to exclude, our liability.

The purchaser has statutory rights in addition to this warranty and this warranty does not affect those statutory rights.

This warranty shall be governed by and construed in accordance with the laws of England and the parties irrevocably submit to the non-exclusive jurisdiction of the courts of England.

Customer's signature:

.....

Date:

.....

Retailer's signature:

.....

Date:

.....

WARRANTY REGISTRATION

The supplying retailer must explain the warranty terms and conditions to you, and complete the warranty registration process online. Your warranty will start on the day that the vehicle is first registered in the UK or 12 months from the date on which the vehicle was invoiced to the supplying retailer, whichever is the earlier.

The name and address of the warranty provider is:

Bailey Caravans Limited, South Liberty Lane, Bristol, BS3 2SS

CENTRAL REGISTRATION AND IDENTIFICATION SCHEME (CRIS)

CARAVAN REGISTRATION

This caravan has been security marked and recorded under the Caravan Registration and Identification Scheme that is recognised by the Caravan Industry and the National Caravan Council.

Shortly after purchasing this caravan you should receive your Touring Caravan Registration Document. It will be sent by post to your home address.

Your Touring Caravan Registration Document will include a 17 character VIN (Vehicle Identification Number), shown in the top right hand corner. This 17 character VIN will also be permanently marked on the caravan chassis.

For security purposes, never leave the Touring Caravan Registration Document in the caravan. It should always be stored in a safe place away from the vehicle.

If you sell the caravan please follow the instructions on the Touring Caravan Registration Document.

If, for any reason, you do not receive a Touring Caravan Registration Document or any of the details recorded are incorrect, please contact:

CRiS, Avonbridge House, Bath Road,
Chippenham, Wiltshire, SN15 2BB or Tel 0203
282 1000.

VIN CHIP CARAVAN IDENTIFICATION

The caravan's unique 17 character VIN will be incorporated into VIN Chip tamper evident labels; the master VIN Chip label is situated on the front near side window, others are located in the gas locker and a maximum of 10 placed on the inside of all windows (with the exception of opaque windows).

Three electronic RFID chips containing the individual identity of your caravan are concealed within the caravan and can only be read by using a specially programmed RFID scanner.

CRIS REGISTRATIONS:

For help, support and advice Contact CRiS:
NCC, CRiS Ltd, PO Box 445, Aldershot, GU11
9SF.

TEL +44 (0) 203 282 1000

COUNTRY AND COASTAL CODE

CODE OF CONDUCT - CAMP SITES

Check the site regulations.

ARRIVALS

Report to reception immediately on arrival.

VEHICLE MOVEMENT

Keep to roadways unless otherwise directed. Adhere to speed limits. Remember that the stopping distance on grass is considerably greater than on tarmac.

Only a person in possession of a current driving licence may drive onsite.

Park as advised on your pitch. Where possible leave 6 metres (20ft) of free space around your vehicle.

USE OF SITE

Use the electrical mains hook-up in the correct manner and with caution.

Ensure that all fresh water taps and connections are turned off after use.

Have care and consideration for others when using all facilities. Leave them clean and tidy. Ensure young children are accompanied at all times.

CAUTIONS

To avoid possible damage to sewage purification works, only approved chemical fluids must be used. Under no circumstances may coal tar, phenol or caustic-based fluids be used. Disposable nappies and similar bulky items must not be put into the chemical closet emptying points but should be wrapped in a polythene bag and placed in the container provided.

NOISE

All occupants should refrain from making excessive noise.

Flying kites and model aircraft and the use of items like catapults or air guns, as well as ball games, should not be permitted among or close to caravans.

Musical instruments, music players, radios and televisions should not be used to the inconvenience of other people onsite.

Open and close doors quietly.

Power generators must be adequately silenced and used with consideration in accordance to

restricted site times.

DOGS AND PETS

All dogs and other pets should be kept under control.

Unless permission has been granted, no animal should be let loose on the site and leads should not exceed 3 metres (10 ft).

No animal should be allowed in the shower/ toilet block.

Do not let animals foul the site.

FIRE PRECAUTIONS



Adhere to and make note of all fire precautions, including the whereabouts of the fire points.

It is recommended that a 1kg (2.2lb) dry powder fire extinguisher is carried within the caravan. It should comply with BS 5423 ISO 7465 and be marked BSI or FOC approved. It is important to check at regular intervals that the extinguisher is working as is required by types meeting BS 5423. Ensure the use-by date is frequently checked.

Careful thought is necessary for the positioning of a fire extinguisher, which should be near to the door but not too close to cooking equipment where flames could make it unreachable.

In the kitchen area, a fire blanket is a worthwhile precaution.

Unless permission has been granted, barbecues should not be used. When permission has been given, take care and consider other site users. Ensure that the environment remains pleasant for everyone.

AWNINGS AND TENTS

Awnings and tents should only be used when permission has been granted.

When on grass and staying for more than a few days, the ground sheet and/or side flaps of awnings should be periodically raised in order to avoid damage to the ground.

DEPARTURE

Leave the pitch clean and tidy.

Upon leaving, check out with reception, paying the required dues.

Under no circumstances should:

- Litter be disposed of other than in the receptacles provided.
- Water be allowed to escape from the vehicle.
- Chemical toilets be emptied except into the disposal places agreed with the landowner.
- Washing or similar be hung outside of the vehicle.

HANDBOOK

Before using the caravan, all aspects of the handbooks should be read and adhered to.

ENVIRONMENT

Care and consideration should be taken to protect the environment.

Observe the Country and Coastal Codes shown below.

THE COUNTRY CODE

Enjoy the countryside but respect its life and worth.

More people than ever before are exploring the countryside, interested in farming, plant life, bird watching or just observing the general wildlife. Whatever your interest, there is a lot to learn. Please observe the following code.

- Guard against all risk of fires. Hay and heath land can catch alight easily and once ablaze are very hard to put out.
- Remember fire spreads quickly.
- Keep to public paths across farmland.
- Use gates and stiles to cross fences, hedges and walls.
- Leave livestock, crops and machinery alone. View from a distance.
- Take your litter home; it is unsightly and harmful to wildlife.
- Help to keep all water clean.
- Take special care on country roads.
- Make no unnecessary noise. Most animals are timid, noises can disturb them unnecessarily.

If you want to get the best out of the countryside, travel around as quietly as possible.

THE COASTAL CODE

As our coastlines are increasingly used for recreation and education, the following suggestions are made to enable us to enjoy our inheritance and preserve it for posterity.

- Do not trample about, or move rocks unnecessarily.
- Do not frighten seals or sea birds.
- Do not spear fish.
- Live molluscs and crustaceans should not be collected as souvenirs, dead shells can usually be found;
- Shellfish can take years to grow and fines can be imposed for not observing national regulations.
- Do not pull up seaweed unnecessarily.
- Make your visit instructive, not destructive.
- Look at material, don't remove it.
- Observe bye-laws and be considerate to others.
- National Trust property or Country Parks have regulations to protect the wildlife. Follow these.

ROOF LOADING



Do not allow children to climb on the roof of your caravan.

Take special care when on the roof, particularly in wet or frosty weather conditions, when the surface could be slippery. Always wear practical footwear when climbing onto your vehicle.

SAFETY AND SECURITY



Your attention is drawn to the notice fixed in your Caravan advising on fire protection, ventilation and what to do in case of fire.

CHILDREN

Never leave children alone in the caravan. Ensure all potentially dangerous items are kept out of reach.



When upper bunks are used by children, especially those under the age of six (6), care should be taken to ensure against the risk of them falling out. These bunks are not suitable for use by infants without supervision.

UPPER BUNKS

Please ensure upper bunks are only used for sleeping. When upper bunks are used fall out protection must be always be in place.

FIRE EXTINGUISHERS

It is recommended that a 1kg (2.2lb) minimum capacity dry powder fire extinguisher be located near to the main habitation entrance door.

A pan fire should not have a fire extinguisher aimed at it. A fire blanket should be used. This should be within easy reach of the hob but away from the source of flames.

IN CASE OF FIRE

- Get everyone out of the caravan as quickly as possible using whichever exit is quickest, including windows.
- Raise the alarm - call the fire brigade.
- Turn off the gas bottle valve if it is safe to do so.



Your caravan is fitted with a smoke alarm. The operation of the alarm should be tested after the vehicle has been in storage, before each trip and at least once per week during use.

VENTILATION AND CONDENSATION



The ventilation points on your caravan are fixed points specified by European standards. Under no circumstances must these be blocked or obstructed. It is advised that fixed ventilation points and any protective screens are checked and cleaned on a regular basis.

Fresh air circulation should be allowed below the caravan when appliances are in use and when flues terminate below the floor to allow free evacuation of the products of combustion. At least three sides of the under-floor space should be kept clear and unobstructed, including by snow. Do not make any additional openings in the floor.

Additional night-time ventilation is obtained by releasing the window catches and placing them in the second groove on the frame catch.



Under no circumstances should the caravan ventilation be covered, blocked or tampered with in any way.

PETROL AND DIESEL FUMES

The fitting of a tail pipe deflector to your exhaust will reduce the possibility of fumes entering your caravan through the front fixed ventilation points. However fitting an extension to an exhaust tail pipe will render the exhaust illegal if it projects beyond the vehicle body or bumper.

ORIGINAL EQUIPMENT APPLIANCES

See sections devoted to individual appliances.



Replacement parts for any appliance must conform to the appliance manufacturer's specification, and must be fitted by an authorised agent.

PORTABLE APPLIANCES



Never use portable cooking or heating equipment, other than electrical heaters that are not of the direct radiant type.

MODIFICATIONS



Never allow modification of electrical or LPG (liquefied petroleum gas) systems and appliances except by qualified persons.



In the interest of safety, replacement parts for an appliance shall conform to the appliance manufacturer's specifications and should be fitted by said manufacturer or authorized agent.

CARAVAN AND TOW VEHICLE

Choosing the right car and caravan combination for safe and stable towing is an important process. It may seem complicated to the newcomer, but a few minutes spent learning the basic principles, common terms and definitions will be worthwhile in the long term and ensure your enjoyment of the caravan.

CARAVAN AND TOWING VEHICLE TERMS

MAXIMUM TECHNICALLY PERMISSIBLE LADEN MASS (MTPLM)

As stated by the vehicle manufacturer. This mass takes into account specific operating conditions including factors such as the strength of materials, loading capacity of the tyres etc. MTPLM is the maximum permissible weight of caravan on the road.



Under no circumstances should the MTPLM of the caravan be exceeded.

MASS IN RUNNING ORDER (MRO)

Mass of the caravan equipped to the manufacturer's standard specification and essential habitation equipment.

USER PAYLOAD

The difference between the maximum technically permissible laden mass and the mass in running order.

The user payload includes:

Personal Effects: Those items which a user chooses to carry in a caravan and certain items of habitation equipment which are not included in the MRO or Optional Equipment.



Personal effects will include any items not supplied as standard by the manufacturer. This includes 25kg for the leisure battery.

OPTIONAL EQUIPMENT (OE)

Items made available by the manufacturer over and above the standard specification of the caravan. These are factory fitted options.



Please make sure your personal effects stay within the allocated payload. In no circumstances should the caravans actual weight exceed the stated MTPLM.

Please note: weigh bridges may give varying (possibly inaccurate) results.

Nose Weight: The downward force (or weight) of the caravans coupling head on a car's towball. This is sometimes defined as the "static load at the coupling head". The maximum nose weight for a caravan will be limited by either the towing vehicle tow hitch limits or the maximum load to which the caravan hitch is specified.



The towing vehicle and towing hitch handbooks/manufacturer's guide must be consulted for their specification prior to towing.



The maximum static nose weight for all Bailey caravans is 100kg. This should never be exceeded regardless of whether the towing vehicle's upper limit is greater.

It is recommended that the nose weight should be varied to find the optimum weight for towing dependent upon the actual laden weight of the caravan.

MEASUREMENT OF THE NOSE WEIGHT

Nose weight may be measured using a proprietary brand of nose weight indicator. Such equipment is obtainable from your Bailey retailer.

KERB WEIGHT

The weight of the towing vehicle as defined by the vehicle manufacturer.

This is normally:

- With a full tank of fuel
- With an adequate supply of other liquids incidental to the vehicle's propulsion
- Without any drivers or passengers
- Without any load except loose tools and equipment with which the vehicle is normally provided
- Without any towing bracket.

THE CARAVAN TO TOWING VEHICLE WEIGHT RATIO

The caravan should never exceed the weight of the towing vehicle.

The optimal combination is a caravan that weighs less than 85% of the towing vehicle's kerb weight.

The following equation can be used to calculate the above.

$$\frac{\text{Actual laden mass of caravan}}{\text{Kerb weight of towing vehicle}} \times 100 = \%$$

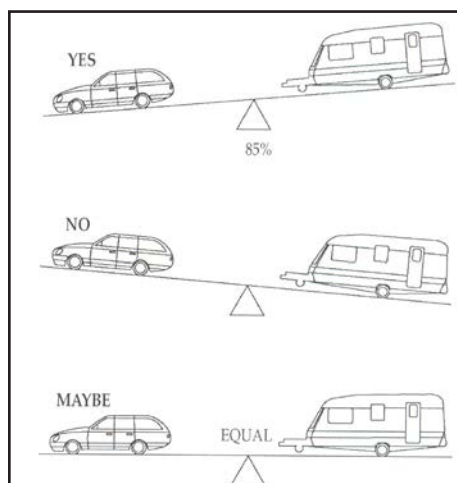

As a general guide:

- Conventional engines with a capacity of up to approximately 1600cc petrol or 1800cc diesel should be adequate for towing a caravan weighing around 85% of the kerb weight of the towing vehicle.
- Engines above 1600cc petrol or 1800cc diesel should manage a caravan weighing up to 100% of the kerb weight of the towing vehicle and still give adequate performance.

The towing vehicle's manufacturer towing limit is, in some cases, less than the kerb weight. Vehicles with automatic transmission may need an oil cooler fitted or the SAE (Society of Automotive Engineers) rating of the gearbox

fluid increasing when towing. The advice of the vehicle manufacturer should be sought. The law requires that caravans, their towing vehicles and the loads they carry must be in such a condition that no danger or nuisance is caused.

TOWING VEHICLE'S REAR SUSPENSION

It is important that the towing vehicle's rear suspension is not deflected excessively by the nose weight. If it is excessive the steering and stability will be affected and at night the headlight beam is likely to dazzle other drivers.

The greater the towing vehicle's tail overhang (the distance between the rear axle and the towball), the greater the effect the nose weight will have on the towing vehicle's rear suspension.

After trying out the caravan it may be found that stiffening of the rear suspension is necessary but note that this may give the towing vehicle a firmer ride when not towing.

There are a number of suspension aids available and advice should be sought on which should be used and how installation should be carried out.

It is important to ensure that the caravan is towed either level or slightly nose down. If it is not, then the car's towbar may be at the wrong height.



Always consult your tow vehicle manufacturer for advice on towing and the loads that the vehicle is capable of towing.

RECOMMENDED TOWBALL HEIGHT

The recommended towball height for Bailey caravans is 385 +/- 35mm (350mm to 420mm).

SECONDARY BRAKING CABLE (BREAKAWAY DEVICE)

Purpose - To apply a trailer's brakes if it becomes separated from its towing vehicle. Having done this, the cable assembly is designed to part, allowing the trailer to come to a halt away from the towing vehicle. **Construction**; A thin steel cable, coated in red plastic and fitted with a means of attachment for connection to the towing vehicle.

Operation - In the event of the main coupling of the trailer separating from the towing vehicle, the cable should be able to pull tight, without any hindrance, engaging the trailer's brakes.



The breakaway cable should never become taut during normal use.

Regularly check the cable and clip for damage. If in doubt, contact your trailer or towbar supplier or your service agent.

Make sure the cable runs as straight as possible and goes through a cable guide underneath the trailer coupling. Determine whether or not the towbar has a designated attachment point (i.e. a part specifically designated by its manufacturer for a breakaway cable).

Where a designated attachment point is provided on the towbar:

- Pass the cable through the attachment point and clip it back on itself.

Where no designated attachment point has been provided on the towbar:

- Fixed ball: Loop the cable around the neck of the towball. Use only a single loop.
- Detachable ball: You must seek guidance on procedure from the towbar manufacturer or supplier.

OTHER MEANS OF ATTACHMENT

In some instances it may be possible to attach the cable assembly:

- To a permanent part of the towbar structure, as long as this meets the approval of the towbar manufacturer/supplier,
- To an accessory sold for the specific purpose of breakaway cable attachment.

When the breakaway cable is attached, check to ensure:

- That the cable cannot snag in use on the caravan coupling head, jockey wheel, or any accessory, e.g. a stabiliser, bump shield, cycle carrier, etc.

- That there is sufficient slack in the cable to allow the towing vehicle and caravan to articulate fully without the cable ever becoming taut and apply the brake. For peace of mind you might wish to check the state of the cable by positioning the caravan and towing vehicle at extreme angles before setting off.

- That it is not so slack that it can drag on the ground. If left loose, the cable may scrape along the ground and be weakened so that it subsequently fails to do its job. The cable may also be caught on an obstacle when in motion, thus engaging the caravan's brakes prematurely.

Having followed this advice, should you feel that a satisfactory coupling arrangement cannot be achieved, consult your trailer/towbar supplier or service agent.



It is a legal requirement that the secondary breakaway cable is used when towing.

LOADING AND DISTRIBUTION OF WEIGHT IN THE CARAVAN AND CAR.

Equipment and personal effects should be loaded in the caravan so that any heavy items are low down near to the floor and mainly over the axles.

The remainder should be distributed to give a suitable nose weight at the towing coupling.

It should be noted that with certain layouts or models it may be necessary to load heavy items, such as awnings, in the middle of the floor to achieve an acceptable and safe nose weight. It may not be possible to achieve the desired nose weight with all items stored out of sight in lockers and bed boxes (bunks).

Please take care that you have allowed for the weight of all items you intend to load into the caravan.

NOSE WEIGHT

It is recommended that the nose weight should be varied to find the optimum weight for towing, dependent upon the actual laden weight of the caravan. Experience has shown

that the nose weight should be approximately 7% of the actual laden weight (i.e. between 50 and 100kg). However, this may be limited by the towing vehicle or caravan manufacturer's limit nose weight. Check with the car handbook, or consult your retailer. The upper limit for the caravan coupling head is 100kg.

HITCHING UP

Before hitching up the vehicle always check the following:

1. All wheel bolts are tightened to the correct torque. When fitted with alloy wheels, bolts should be tightened to a torque of 130Nm (Newton metres). For the steel spare wheel supplied with the caravan the wheel bolts should be tightened to 120Nm.

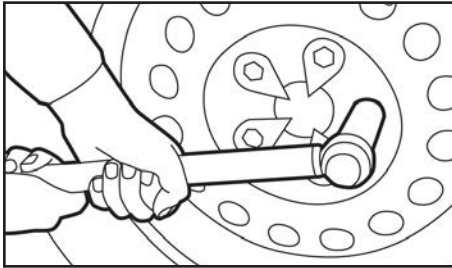

2. Inspect all wheels and tyres for signs of deterioration or damage.
3. Tyre pressures are correct.

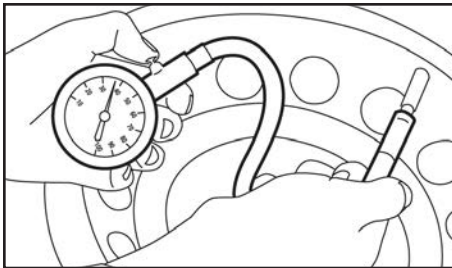

4. Ensure all loose articles are stowed securely. Do not store heavy items in roof lockers. Televisions and other heavy items must always be secured at floor level when towing.
5. All lockers and cupboard doors are closed and secured.
6. All bunks are secure.

7. All rooflights, extractor fans and sunroofs are closed and secured.
8. Tables are secured in their transit position.
9. Fridge is on 12v operation and the door lock is set (if required).
10. All windows are fully closed and latched. Never tow with windows on night setting.
11. Gas cylinders are correctly positioned, secured and turned off, and the gas box is shut and locked.

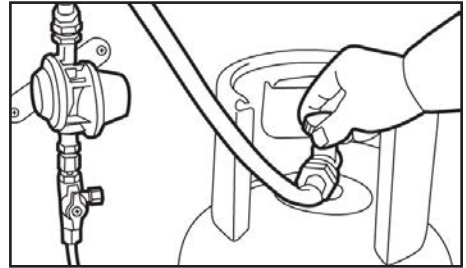

12. Ensure no loose items are stored in the gas box and it is not over filled with equipment, as this may cause impact damage to the inside of the panel.
13. Battery is connected and the battery is secure.
14. All external doors, flaps and ventilation ducts are closed and secure, with their relevant covers in place.
15. Before commencing any journey always ensure that the rooflights are closed and both handles are securely fastened.
16. It is recommended that a minimum of 2 people work together when hitching up the caravan to the tow vehicle.

HITCHING THE CARAVAN TO THE TOW VEHICLE

1. Ensure that the caravan is in a suitable position, and secure with the handbrake fully on.
2. Fully raise all four corner steadies.
3. Shut and lock the caravan exterior.
4. Gauge the height of the car's towball then raise or lower the height of the caravan's towing hitch to ensure that it is high enough to pass over it cleanly and not hit the towball. Rotating the caravan's jockey wheel handle can do this: Clockwise to lower, anti-clockwise to raise.
5. The assistant should position themselves by the front near side of the caravan so

that they can extend an arm horizontally to indicate the position of the caravan's towing hitch.

6. Remove the car's towball cover and keep it in a secure place in the car.
7. Slowly reverse the towing vehicle towards the caravan. When reversing the towing vehicle towards the caravan always ensure that any pedestrians and your assistant are visible at all times.
8. When reversing aim the towball of the car directly at the caravan towing hitch.
9. When the car's towball is as near to the caravan's towing hitch as possible fully apply the car's handbrake, turn off the engine and leave the car in first gear (Park or 'P' position for automatics).
10. The final positioning should be carried out by manoeuvring by hand.
11. Carefully release the caravan's handbrake.
12. Manoeuvre the caravan's tow hitch directly over the towing vehicle's tow ball. Always manoeuvre the vehicle by pushing/pulling on the grab handles. When the caravan is in the correct position fully apply the handbrake.
13. Raise the handle on the caravan tow hitch until it clicks and remains at an angle.
14. Rotate the jockey wheel handle clockwise to lower the hitch onto the towball. When the tow hitch clicks and the handle drops to the horizontal position it is engaged. The hitch head is fitted with a visual indicator on the front radius to show whether or not it is properly connected to the tow ball. A green band will show immediately below the red indicator button on the hitch head when a proper connection has been made.
15. Connect secondary braking cable as per the instructions in the previous section.
16. Test that the hitch is now fully engaged by slightly raising the caravan hitch from the car towball by winding the jockey wheel handle anti-clockwise. The hitch should not release from the car towball. Only raise the rear of the car enough to check the hitch is fully engaged.
17. Turn the jockey wheel winding handle to lower the caravan. When the wheel is fully retracted, release the clamp and raise the jockey wheel to travel position.
18. Once the jockey wheel is in travel position and the wheel is located in the recess, tighten the clamp again.
19. All caravans are fitted with a single 13 pin

lead. Where the connector for the car does not match that of the caravan an adaptor or replacement cable will be required. Please ask your supplying retailer for details.

20. Connect the lead to the receiving socket on the towing vehicle ensuring there is enough loose cable for cornering, but not too much so that it can drag on the ground.

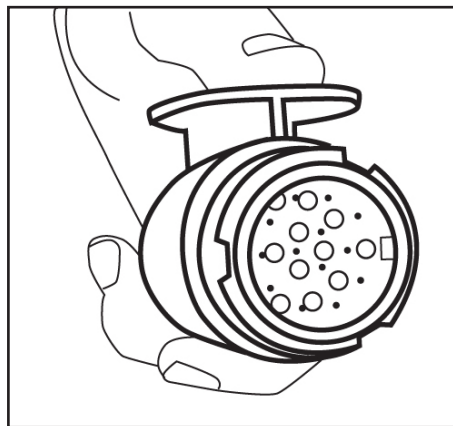

21. Check all towing vehicle and caravan road lights are working, and the operation of the brake lights.
22. Pick up any levelling pads or levelling boards.
23. Fully release the caravan handbrake.
24. Carry out a second check that the hitch is secure and the secondary braking cable is connected.
25. Adjust the car's driving mirrors from the driving seat to ensure good rearward visibility.

TOWING

TOWING VEHICLES

Your new caravan is designed to be towed by a normal motor car.

If you intend to tow it with a Pick-up type vehicle, car derived van or a 4x4 vehicle additional care should be exercised due to the potential of harder rear suspension imposing excessive loads/force onto the caravan. You may also have to adjust your driving style over rough terrain. Particular attention should be given to the height of the tow ball in relation to the caravan coupling.

Your new caravan should not be towed by a commercial vehicle with a gross vehicle weight in excess of over 3500kgs.

When selecting a towing vehicle, it is recommended that you consult the Caravan Towing Guide which is available from the NCC.

SPEED LIMITS

Where a lower limit is not in force, caravans may be towed at up to a maximum of 50 mph on single carriageways or 60 mph on dual carriageways and motorways.

PULLING AWAY

- Allow more engine speed to produce the power to move the additional weight of the caravan.
- Always let the clutch out smoothly, to avoid wear and tear on the clutch plate and transmission.
- Change gears smoothly. Ensure optimum revs are always used when changing gears.
- Try not to drop the clutch.

CARAVAN HANDLING

- Make allowances for the caravan being slightly wider than the car.
- Allow additional distance from the kerb with caravan wheels so that they are not "kerbed".
- When passing other vehicles allow more than normal clearance for driving solo.
- Overtaking and stopping distances are increased when you are towing.
- Always indicate in plenty of time before carrying out any manoeuvre.
- Allow longer to accelerate up to speed prior to overtaking.

- Allow for the vehicle being twice its normal length.
- Do not suddenly swing out.
- Carry out all manoeuvres as smoothly as possible.

REVERSING

Skilled reversing can only be achieved with practice and should be first attempted in an open area. Consider a suitable training course.

MOTORWAY DRIVING

Caravans may not be towed in the outside lane of three or four lane Motorways (Reg 12(2) of the motorway Traffic [England and Wales] Regulations 1982).

Reduce speed in high winds, cross winds, driving downhill or in poor visibility. High-sided vehicles such as lorries or coaches can cause air buffeting, so extra care must be taken when passing or being passed. Give as much space as is possible between your caravan and the high-sided vehicle.

MIRRORS

The law requires the driver of the towing vehicle to have an adequate view to the rear. If there is no rear-view through the caravan windows it may be necessary to have additional exterior towing mirrors fitted to provide a view along both sides of the caravan. In some countries these additional mirrors are a legal requirement.

Any rear view mirror must not project more than 200mm outside:

- The width of the caravan when being towed.
- The width of the towing vehicle when driven solo.

Any additional rear-view mirror fitted shall be of an approved European type and cover the field of view as stipulated by the regulators.



Passengers are forbidden to ride in a caravan at any time.

SNAKING

This is a term used to denote an unstable car and caravan combination where the caravan "weaves" from side to side often causing a similar swaying movement in the car itself. Possible causes are:

- Insufficient tyre pressure on either the caravan or the tow vehicle.
- Tow vehicle is too light.

- Incorrect loading or weight distribution.
- Excessive speed especially downhill.
- Side winds.
- Overtaking.
- Being overtaken by a high-sided vehicle.
- Erratic driving.
- Mixing radial and cross ply tyres.
- Nose of the caravan is towing too high.
- Insufficient nose weight.

STABILISERS

A stabiliser should never be used to try to improve a caravan/towing vehicle combination that has poor stability as instability may appear at high speed.

However, a good stabiliser can make an acceptable caravan and towing vehicle combination more comfortable and easier to handle.



Holes should not be drilled in either the coupling head or A frame members without prior consultation with the chassis manufacturer.

If you encounter snaking, try to keep the steering wheel in a central position, slow down gently and avoid braking if possible.

ROAD LIGHTING

All caravans are fitted with a single 13 pin lead. When the connector for the car does not match that of the caravan an adaptor or replacement cable will be required.

Please ask your supplying retailer for more information.

LIGHTS

It is important that all the road lights on your Bailey caravan are checked before you set out on a journey.

All lights must be working in the correct manner for the vehicle to be road legal.

Clean the outside of the lights with a non-abrasive or non-aggressive cleaning solution on a regular basis.

Always replace a lamp which is showing any sign of damage.

13 PIN PLUG

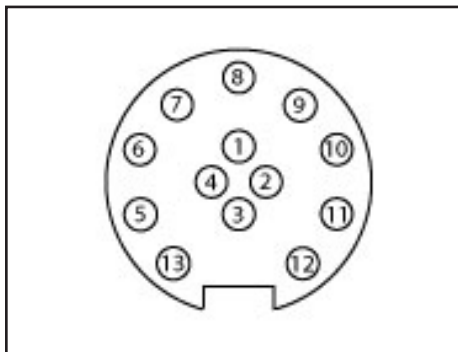

KEY:

1. Left-hand direction, indicator light
2. Right fog light
3. Common return for Core # 1, 2 and 4 to 8.
4. Right-hand direction indicator light
5. Right-hand rear position and marker lights and rear registration, plate illumination device.
6. Stop lights
7. Left-hand rear position and marker lights and rear registration, plate illumination device
8. Reversing light
9. Continuous power supply
10. Power supply controlled by ignition switch
11. Return for core # 10
12. Coding for coupled trailer
13. Return for core # 9

Within your accessories pack you will find a green 13 pin plug protection screw on cap. This should be used every time you connect your caravan to your vehicle. This will help to protect the 13 connections from corrosion. If you find corrosion on you connections please spray with water displacement spray.

TOWING BRACKETS

All tow cars registered since 1 August 1998 must be fitted with a European type-approved towing bracket, by law. It is recommended that other cars not affected by this law use only towing brackets designed and tested to British Standard BS (AU) 114b, or ISO 3853.



LAMILUX COMPOSITES

*Fibre-reinforced composites -
the high-tech material for roofs, walls and floors*

Long lasting, very light and strong, especially resistant to damage from hail and minor impacts, whilst also being resistant against corrosion. Fibre reinforced composites are the ideal facing sheets for the sandwich panel

elements used in the construction of all areas of caravans and RVs, whether the external or internal walls, floor or roof - fibre reinforced composites from Lamilux are technical and visual highlights.



LAMILUX GRAPH
for the inner wall

LAMILUX HG 4000
for the outside wall

**LAMILUX
SUPER PLUS MATT**
for the inner wall



All tests certified in compliance
with **TÜV Süd** quality

TÜV SÜD certified quality



SALES REPRESENTATIVE IN GREAT BRITAIN:

GRP Marketing Ltd. | Nick Guscott | Tel.: +44 (0) 798 083-5431 | E-mail: nick@grpmarketing.com

LAMILUX COMPOSITES GMBH

Zehstraße 2 | 95111 Rehau/Germany | Tel.: +49 (0) 92 83 595-0 | Fax: +49 (0) 92 83 595-29 0 | E-mail: information@lamilux.de

WWW.LAMILUX.COM

UNHITCHING

- Do not pitch in a position in which your outfit will obstruct other people.
- Try to choose an area that is dry, reasonably level and preferably on hard standing ground.
- If you have no alternative but to pitch on a slope, ensure that you are facing down the slope for when you leave.
- It is good practice to chock the wheels of the caravan when parked on a slope even when the caravan brakes are applied.

PROCEDURE

1. Fully apply the caravan handbrake.
2. Unclasp and lower the jockey wheel to the ground.
3. Re-clamp it in this position.
4. Pull the stabiliser lever up as far as it will go, open the coupling handle and lift from the towball. With larger nose loads, coupling and uncoupling can be made easier by using the jockey wheel to assist lifting.
5. Re-clamp jockey wheel if necessary.
6. Disconnect the secondary braking cable.
7. Disconnect the 13 pin plug and return it to its holder.
8. Replace towball cover.
9. Park your vehicle alongside the caravan on the offside.



Serious damage will occur unless the button is depressed first and the handle lifted forward before the caravan is lifted manually. This prevents the nose weight being transmitted through the button.

LEVELLING THE CARAVAN

Levelling must be carried out in both directions in order for the refrigerator and other equipment to function correctly. A spirit level can be used as shown in the picture however there are many free to download applications available on your compatible device.



The positioning of the jockey wheel can be used to help level the caravan.

Lower the corner steadies until they are in firm contact with the ground.



Under no circumstances should the corner steadies be used as a jack as they are only a means of stabilising the caravan.

Levelling pads or boards should be used under the steadies where the ground is soft or uneven. In extreme cases where it is necessary to raise a wheel off the ground for levelling purposes, further adequate support should be applied under the wheel so that the corner steadies do not take any undue strain.

WHEELS AND TYRES

All Bailey vehicles use branded tyres. These are subject to change at any point without prior notice.

TYRES

The tyres on Bailey caravans are suitable for towing at sustained speeds of up to 81 mph (130 kph) to allow for use in countries which permit these speeds.

Radial and cross ply tyres should never be mixed. It is dangerous and can cause snaking. Fit only tyres that are of identical specification on each side, unless towing for a limited time on the spare wheel.

TYRE WEAR AND DAMAGE

The legal requirements for tread depth on motor vehicles also applies to caravans.

In order to equalise wear it is suggested that wheels be balanced and changed around from time to time. When caravans are not in use for extended periods, wheels and tyres should be removed and stored in dry conditions and away from the outside elements. Alternatively caravans should be jacked up to relieve the load from the tyres.

It is dangerous to neglect tyre damage. Tyres should be checked for damage or cuts exposing the casing. If a tyre has suffered an impact (for example against a kerb) it is advisable to have it examined by a tyre specialist as soon as possible.

The caravan industry recommends that for safety reasons tyres more than 7 years old from the date of manufacture must be replaced, but preferably replaced at 4 years old. The tyres may have deteriorated by this time, regardless of tread depth.

The cleaning of tyres should only be carried out using soap and water. Petrol, diesel, paraffin and other solvents are not suitable.

If the caravan is not used for long periods of time (periods of longer than 1 month), it is recommended that the wheels/tyres are removed and stored upright in a rack and rotated at least once a month to avoid the tyres becoming distorted. They can be

covered with a natural material (e.g. hessian) for protection but NOT plastic materials. This will reduce the deterioration of the tyres and reduce the cracking and flat spots caused by continuous loading and external conditions. It is recommended to protect tyres from direct sunlight.

If it is not practical to remove the wheels it is recommended to routinely rotate the wheels to reduce the potential of cracking, flat spots etc.



Check with your insurance company that you are still covered when the wheels are removed.

TYRE PRESSURES

Caravan tyres should be at the pressure recommended. The towing vehicle's tyres should be set to the pressure recommended by the vehicle manufacturer for laden conditions. This will ensure the tyres and vehicle operate in a safe condition and maintain stability of the vehicle when towing.

Always check your caravan and tow vehicle tyre pressures when cold and prior to any journey. Also check tyre conditions for damage or cuts exposing the casing before and after any journey (this includes the spare.) If in doubt it is advisable to have it examined by a tyre specialist as soon as possible. Incorrect tyre pressures can seriously affect towed vehicle performance and the longevity of the tyre.

Consult your tow vehicle manufacturer for the correct tyre pressures for towing.

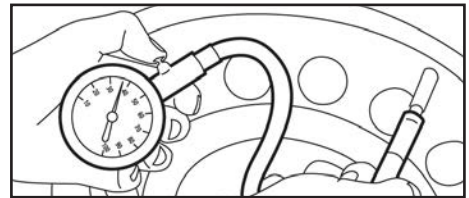

WHEELS

Caravan wheel bolts must only be tightened to the appropriate setting by tightening each opposite fixing in succession to the correct torque. Always use a calibrated torque wrench. Do not use a corner steady brace, power or electric wrench. It is as dangerous to over-tighten bolts as it is to not tighten them sufficiently.



The torque settings should be checked after the first 50km/30 miles. For alloy wheels the wheel bolts should be tightened to a torque of 130Nm (Newton metres) (96 lb-ft). For steel wheels the wheel bolts should be tightened to a torque of 120Nm (88 lb-ft).

The condition of wheels should be checked regularly, particularly for distortion of flanges and the wheel dish. Damaged or distorted wheels, or having the wheel bolt seating cracked or deformed, must not be repaired.

If a wheel or tyre has to be changed it should be of the same type of construction and size as originally fitted.



Only use a spare wheel and tyre recommended by Bailey Caravans, which should be of the same specification as those fitted to the caravan.

Always ensure mating surfaces and bolt seating areas are clean and dry. Wheel bolts should never be lubricated.

SPARE WHEELS

Spare wheels are available with some models.

The spare wheel fitted to your caravan is an unbranded tyre.

1. Always ensure that the tow vehicle and caravan are in a safe position before attempting to change the caravan's wheel. We recommend leaving the caravan hitched to the tow vehicle when changing a wheel. The tow vehicle should be left in gear (or "P"/Park for an automatic) with the handbrake on both the car and the caravan fully applied.
2. Lower the corner steadies as a safety

measure to stabilise the caravan. Chock the unpunctured wheel on the opposite side of the caravan to prevent any movement.

3. Slacken off the wheel bolts by no more than one quarter of a turn on the wheel that requires changing. Do not fully undo them.
4. We recommend you only use an AL-KO jack on the AL-KO chassis. Please refer to your AL-KO handbook for jacking instructions.
5. The wheel that is to be removed should be lifted just off the ground.
6. Remove the wheel bolts and remove the wheel.
7. Fit the spare wheel, and reverse the above procedure. Ensure the wheel bolts are all fitted, and tightened in the correct sequence. Ensure correct torque setting.
8. Remember to check the torque of wheel bolts after 50kms/30 miles.



Under no circumstances should the corner steadies be used as a jack. They are only a means of stabilising the caravan.

SPARE WHEEL CARRIER

The spare wheel carrier fitted in your leisure vehicle (model specific) is much like that fitted onto a car.

TO LOWER THE SPARE WHEEL:

1. Remove the plastic stopper in the floor.
2. The winder for the spare wheel carrier can be found in the kit bag supplied with the vehicle.
3. Remove the winder from the kit bag and insert the hooked end of the crank in the spare wheel retaining attachment.
4. Lower the spare wheel to the ground, with a little amount of slack. Pull the wheel out as far as possible before slackening the cable further. Repeat until the wheel is in the desired position.
5. Draw the spare wheel towards you from under the leisure vehicle.
6. Pivot the toggle at the end of the cable 90 degrees to release it from the spare wheel.
7. Crank up the cable again by turning the crank clockwise.
- 8.

RETURNING THE SPARE WHEEL TO THE STORAGE COMPARTMENT:

1. Use the crank to lower the spare wheel's retaining cable. When there is no wheel attached, the cable will need to be gently pulled from the carrier.
2. Pass the toggle at the end of the cable through the centre hole in the spare wheel. Pivot the toggle 90 degrees so that when raised, the wheel will rest on the toggle.
3. Retract the retaining cable slightly by slowly turning the crank clockwise several times.
4. Position the wheel so that it is not obstructed by components under the floor.
5. Continue to raise the wheel by turning the crank clockwise. Raise the wheel a little bit at a time and guide it until it is securely seated against the floor.
6. When it is no longer possible to turn the crank, check that the spare wheel is seated tight against the underside of the floor.
7. Replace the plastic stopper inside the vehicle.

For full details and instruction on how to use/set up your TPMS please see the manual supplied with the unit.

TPMS TYRE PRESSURE MONITORING SYSTEM (SUPPLIED WITH CERTAIN MODELS OF BAILEY CARAVAN)

This system is designed to monitor the pressure and temperature of wheels and tyres that have been fitted with TyrePal TPMS internal sensors. Additional sensors can be purchased to monitor spare wheels, or the tyres on the towing car.

The system continuously monitors tyre pressure and temperature while the caravan is in motion and gives distinct alerts in the event of:

- Rapid pressure loss
- Low tyre pressure
- High tyre pressure
- High tyre temperature

The system can monitor up to 22 tyres on a car and trailer.



The system does not replace the need to carry out regular checks on the condition, age and wear of tyres.

SAVES FUEL, SAVES TYRES, SAVES LIVES

Tyre Pressure Monitoring Systems

pay for themselves by reducing tyre-related breakdowns as well as improving fuel economy and tyre life.



Did you know the Bailey Unicorn range comes fully equipped with TyrePal tyre pressure monitoring as standard?

TyrePal TPMS continuously monitors the pressures and temperatures of your tyres and warns you if things are going wrong.

It is simple to add **TyrePal TPMS** to your **Pegasus** or **Pursuit** caravan, contact **Bailey Parts Direct** or your dealership for details.

For further information, please visit: www.tyrepal.co.uk

www.tyrepal.co.uk



C3imaging

print & graphics

Delivering high quality print for over 20 years...



DIGITAL PRINT LARGE FORMAT PRINTING STATIONERY MAILING
LITHOGRAPHIC PRINT CORPORATE LITERATURE SIGNAGE BANNERS
VEHICLE GRAPHICS CANVAS PRINTS BUILDING WRAPS POSTERS
PUR/WIRO BINDING PERSONALISATION MANUALS MARKETING MATERIAL

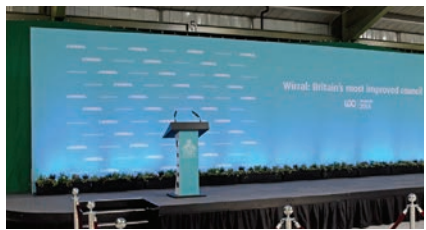
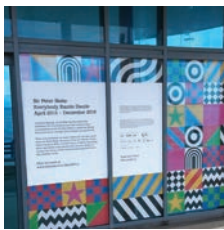

C3imaging South Wales
 Unit 13, Pontyfelin Industrial Estate
 New Inn, Pontypool, NP4 0DQ

- T** 01495 767680
- E** enquiries@c3imaging.com
- W** www.c3imaging.com



Part of the Zenith Print Group



Phoneline
available
7 days a
week

Whale Support

Call today for advice on water systems

Tel: 0345 9090 911

E-mail: info@whalepumps.com

www.whalepumps.com



Exterior Water Pump Range

Easy to fit for high flow rates in your caravan!



EP1612
with High Flow Pump

Compatible with
Whale Watermaster®
Exterior Socket



EP1642
with High Flow Pump

Compatible with
Truma® Ultraflow
sockets



Proud to manufacture in the UK

THE AL-KO AKS STABILISER AND COUPLING

The trailer coupling may only be connected to towing vehicles where clearances for the stabiliser can be observed, in accordance with EC Directive 94/20 (DIN 74058). If these clearances are infringed by special attachments, then the use must be checked separately.

The area above the towball of the vehicle must be free from vehicle components or attachments (A) (e.g. spare wheels, platforms etc.)

The clearance for the stabiliser lever must be at least 330mm (B) + the stroke movement (D) (85mm-100mm), which equates to 440mm when used in conjunction with an AL-KO overrun.

Max. 50mm (C) clearance between the centre of the towball and top of the overrun assembly or fairing, to ensure both coupling handle and stabiliser lever do not foul on operation.

Maintain the same clearances for other manufacturers' overrun assemblies.

May not be suitable for use with overrun devices which can revolve above 25° (Fig 2) or BPW overruns fitted with gas strut handbrakes from 2001 model year onwards (If in any doubt about usage consult your manufacturer).

Swan neck towbars (fixed or detachable) are suitable for use with the AKS 3004 providing they comply to EC Directive 94/20 and have the required minimum 60mm clearance, measured from the centre of the towball.

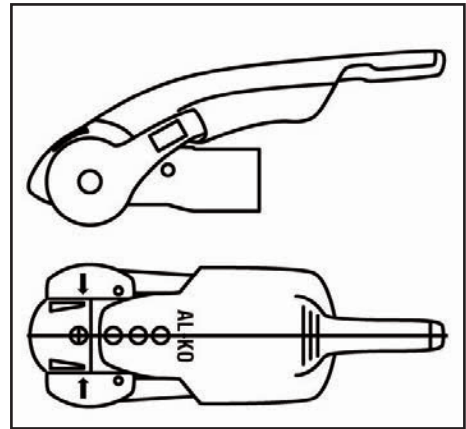
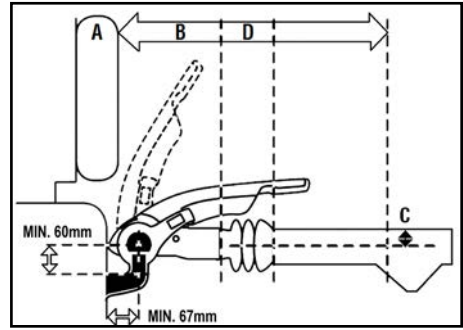

FIG. 1.

OPERATING INSTRUCTIONS

Coupling handle and stabilising lever.

The stabiliser lever (Fig.3/ Item 2) must be in the uppermost position (open).

COUPLING

Pull the coupling handle (Fig. 2/Item 1) up in the direction of the arrow. The coupling mechanism has an open position, i.e. as long as the AKS 3004 is not placed on the ball, the handle will remain open. Put the opened coupling onto the clean towball. The handle must now make an audible click and return to the flat position.

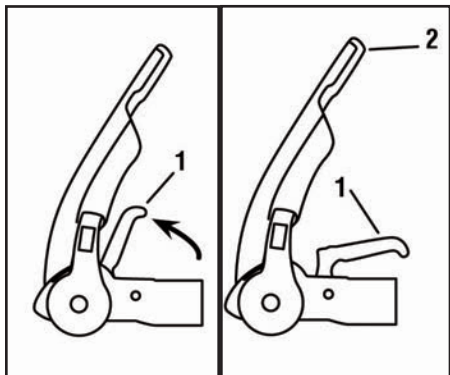

FIG. 2.



The coupling is correctly engaged when the green edge of the safety indicator button is visible (Fig. 4/Item 3.)

Always ensure that the jockey wheel is fully raised and secure before commencing any journey.

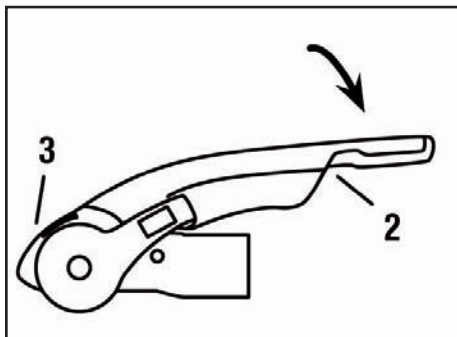

FIG. 4.

STABILISER UNIT

To operate the stabiliser (once coupled to the towball), simply press the stabiliser lever down as far as it will go (Fig. 4/Item 2).

UNCOUPLING

Pull the stabiliser lever handle up as far as it will go, lift the coupling handle and lift the AKS 3004 from the towball. With larger nose loads, coupling and uncoupling can be made easier by using the jockey wheel to assist lifting. The friction pads are pressed against the towball and hence generate a stabilising/damping force. These pads are therefore

subject to wear over time; however they will have a long service life (circa. 30,000 miles), provided they are well maintained and kept free of grease/dirt.

Having lowered the jockey wheel to the ground, operate the handle as previously described. Lift the coupling clear of the towing ball either manually or by operating the telescopic jockey wheel.

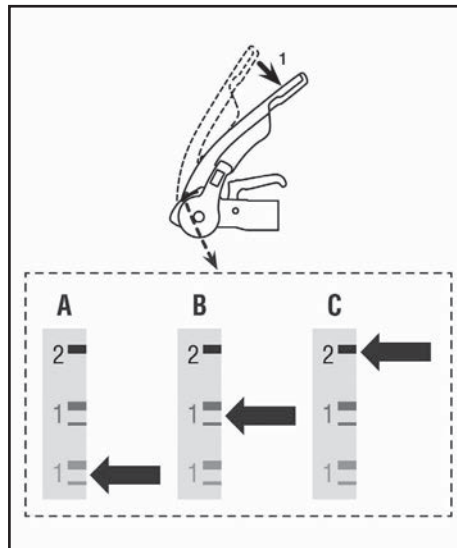

FIG. 5.

Checking the efficiency of the left/right friction pads:

1. Check that the stabiliser is correctly coupled by ensuring the coupling handle is fully down and the red indicator button is in the raised position.
2. Push the stabiliser lever (fig.5/item 1) down until resistance is felt (i.e. the friction pads are in contact with the ball but not yet under pressure).
3. Check the position of the arrowhead on the arm of the stabiliser. If it lines up with the two green lines then the friction pads are still as new (Fig.5/A)



If the arrowhead lines up with the two red lines then the friction pads are worn and should be replaced immediately.

When the stabiliser lever is correctly applied, the arrowhead should link up with the black line marked 2 (Fig 5/C).

The friction pads do not require any form of lubrication and should be cleaned with a fine emery paper prior to every journey. It is not necessary to adjust the friction pads.

MANOEUVRING OPERATION

For easier manoeuvring (on camp sites etc), pull the stabiliser lever to the "up" position. Please do not use the stabiliser lever as a manoeuvring handle. Please use the handles on the caravan or fit the AL-KO manoeuvring handle to your jockey wheel (available separately).

1. During opening or closing, the AKS must only be operated by one person.
2. Press the stabiliser lever down by hand only, DO NOT use your foot or an extension bar: this will damage the components (Fig. 6).
3. When opening or closing the stabiliser lever, please ensure your hand does not touch the coupling handle to avoid injury (Fig. 6.)

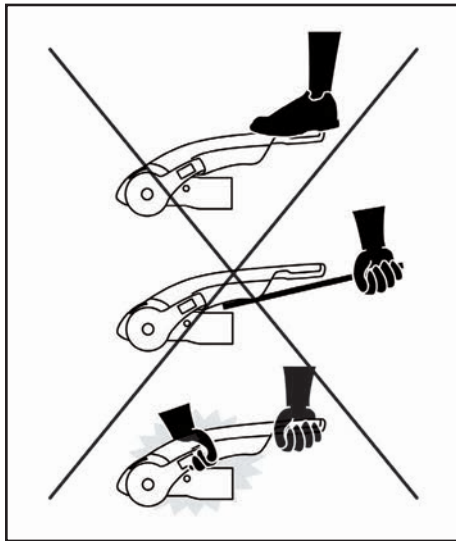

FIG. 6.

NOISES WHILE DRIVING

As a rule, the friction pads of the AKS 3004 do not make a noise during driving. Any clicking, creaking or squeaking noises that do arise may be due to the following:

1. Foreign bodies or dirt between the friction pad and towball.

2. Dry operation of the draw-shaft inside the overrun device.

3. A detachable towball which has too much play in the locking mechanism.

REMEDIAL ACTION

1. Clean the towball and friction pads by lightly rubbing the surface (100-120 grit emery paper)
2. Lubricate the draw-shaft sleeve via the grease nipples. In addition, push the gaiter forward and grease (DIN 51 825 KTA 3K) the exposed part of the shaft (Fig, 7).

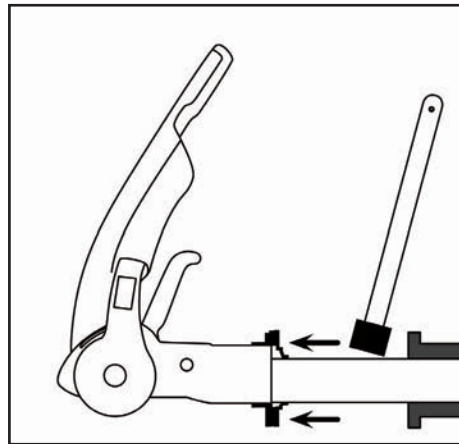

FIG. 7.

3. Visit a specialist workshop to have the ball holding area checked for damage and the locking mechanism for function. If necessary, change the towball.

STORING

To reduce the possibility of contamination of component parts of the AKS 3004 the stabilising handle should be closed.

TOWING BALL

The automobile towing ball should measure 50mm maximum and 49mm minimum diameter (DIN 74058). If the ball is below 49mm diameter it should be replaced immediately.

OVERRUNNING DEVICE

The device housing is packed with grease on assembly, but will require periodic maintenance to ensure smooth operation of the braking system.

- Re-grease the shaft bearings via the grease nipples provided at 3,000 mile intervals, and before storage.
- Ensure correct functioning of all pivot pins and levers, and oil regularly.
- Ensure correct functioning of handbrake ratchet and oil regularly.

JOCKEY WHEEL

Lubricate wheel and screw thread periodically with grease.

BRAKE LINKAGE

All moving parts should be lubricated periodically to ensure their satisfactory operation.

CORNER STEADIES

The screw and pivot pins should be lubricated periodically to ensure their satisfactory operation.

BRAKING SYSTEM ADJUSTMENT

(At 500 miles, then every 3,000 miles or 1 year)

1. Ensure the towing shaft with coupling heads is pulled fully forward.

2. Release the handbrake to the fully off position. If the handbrake will not go down the whole way because of the fairing or any other obstruction then the fairing must be cut away and/or the obstruction removed to achieve this desired position. It will not be possible to set up the braking system properly when the handbrake is not in the fully off position (fig. 8).

3. Jack up one side of the caravan (see Jack Operation Instructions).

4. Remove the inner plastic bung from the backplate to expose the "star-wheel" adjuster access (fig. 8).

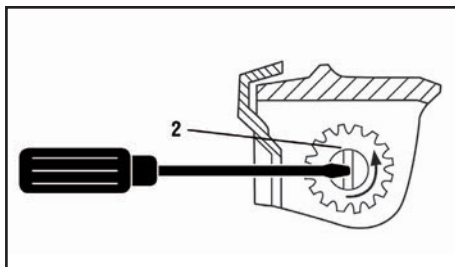
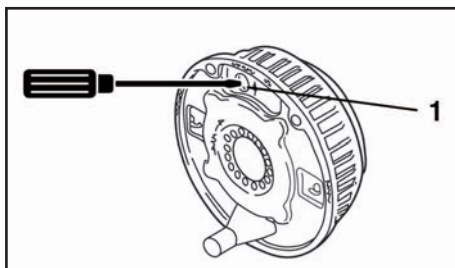

FIG 8.

5. Rotating the road wheel in the forward direction (never backwards), adjust the star-wheel with a suitable screwdriver in the direction of the arrow embossed on the backplate until there is resistance in the wheel rotation (fig. 8).

6. Slacken off the star-wheel adjuster until the road wheel turns freely in the forward direction (fig. 8).

7. Check the adjustment at the end of the brake cable where it is secured to the abutment (bracket) welded to the centre of the axle. When the inner cable is pulled out it should extend between 5 and 8 mm. (On tandem axles a double abutment is fitted to the front axle only).

8. Repeat for other wheel or wheels.

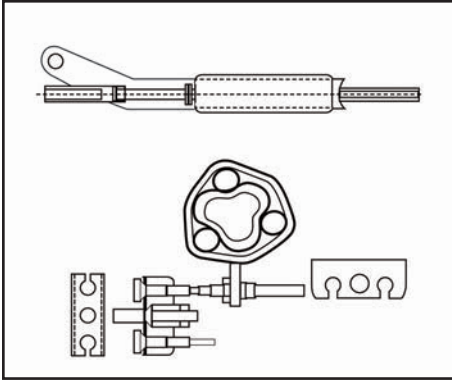

FIG 9.

9. Ensure the balance bar (compensation) is being pulled evenly. This bar (double on tandem axles) should always be paralleled with the axle tube when pulled. Adjust M8 lock and ball nuts, if necessary, to achieve correct parallel position (Fig. 9)

10. Check the brake rod support bracket (fixed to the floor) is supporting the brake rod evenly. The brake rod must always run straight, never bent or curved under any fittings. On tandem axles, using the double balance bar, a brake rod support tube (Part No. 228827) must always be fitted on the end of the brake rod, passing through the centre aperture on the abutment.

11. Remove the slack in the brake rod by adjusting the long ball nut to the rear of the balance bar, ensuring the overrun lever makes contact with the end of the towing shaft. Over-adjustment to the long ball nut (Fig.10) could induce movement of the inner brake cable, reducing the effective clearance of the brake shoes. If the overrun lever will not make contact, it is possible the two lock nuts, forward of the spring cylinder, are incorrectly adjusted. Loosen the nuts and adjust the brake rod as above (Fig. 8).

12. Adjust the two locking nuts, forward of the spring cylinder (Fig. 9) (on some chassis a single Nyloc nut is used) to give 1mm of clearance on the spring cylinder. This cylinder (the energy store for the handbrake operation) must be able to rotate only, not slide on the brake rod. (See Fig. 9) If the overrun assembly is fitted with a gas strut handbrake then no spring cylinder is fitted, ignore this paragraph.

13. Correct adjustment of the linkage is checked by operating the handbrake lever so that when the second or third tooth is engaged, a slight braking force is felt on the road wheels.

14. Over-adjustment of either the wheel brakes or linkage will result in difficult reversing causing the wheels to "lock-up".

15. When parking, the handbrake lever must always be engaged into the fully upright position (90°). This is to compress the spring within the spring cylinder and thereby create an energy store, which will automatically engage the brakes further should the caravan move.

16. If difficulty is experienced in this operation, try easing the caravan backwards with one hand while engaging the handbrake fully with the other. This manoeuvre should not be attempted on a rearwards facing slope. In this case wheel chocks should be used combined with the handbrake.

17. Finally, if the road wheels have been removed, re-tighten using a calibrated torque wrench to 130Nm (on all M12 wheel bolts - in sequence, i.e. North, South, East, West not clock or anticlockwise.) DO NOT overtighten this is just as dangerous as to undertighten, as this can distort the wheel rims. Avoid the use of power wrenches.



The torque settings should be re-checked after 50km/30 miles. Wheel bolts should never be lubricated.



In order to operate the AL-KO braking system correctly adequate traction of caravan wheels is required when reversing. Therefore surface conditions that would result in a lack of traction should be avoided.



Care should be taken when traversing ramps or other obstacles in order to prevent damage to the caravan under gear. When approaching such obstacles reduce towing speed appropriately.

CHASSIS LUBRICATION POINTS

1. Grease the drawbar in the area of the bellows.
 2. Grease the bearing bush through the grease nipples on the housing and the cartridge.
 3. Grease the pivot bolt of the overrun lever and handbrake levers through the grease nipple.
 4. Grease the joint of the brake rod and fitting.
 5. Oil the joints of the spring cylinder in the handbrake lever.
- Lubricant type: Multi-purpose grease to DIN 51825 KTA 3K4.

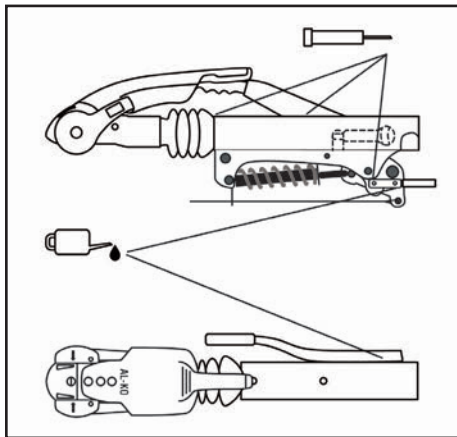

AL-KO ATC TRAILER CONTROL SYSTEM

AL-KO ATC is an electronic, emergency control system for caravans and trailers. It automatically recognises critical swinging motions and applies the caravan brakes accordingly to regain control of the caravan and car.

SAFETY INFORMATION



AL-KO ATC is a passive safety product that activates the braking system on the caravan in unsafe driving conditions.

The driver has a responsibility under law to ensure that the elements of towing safety are met, including driving within the legal speed limit, consideration of road, weather and other traffic conditions, also the correct loading and coupling of the caravan.

OPERATING INSTRUCTIONS

After coupling the caravan correctly to the towing vehicle, connect the 13 pin plug to the towbar.

Upon connection, ATC will carry out an initial self test and the LED light on the front fairing will light up on RED. During the self test, the sound of the push rod moving inside the ATC can be heard. When the self test is complete, the LED will turn GREEN or flashing GREEN to signal that the ATC is active.

If the LED does not change to GREEN, then the ATC is not functioning correctly.

Prior to commencing any journey, ensure that the caravan lighting is fully operational and check the vehicle is loaded appropriately, the nose weight and tyre pressures are correct, and confirm that the caravan is coupled to the vehicle with the breakaway cable correctly applied.

Always re-check that the ATC LED is green after any interval during a journey, such as a service station break.

Always disconnect your ATC once parked on a ferry, ensuring you reconnect before you restart the engine and leave the ferry. This will ensure that your battery is not run down during the crossing.

Should you experience any issues with your ATC please contact AL-KO or the supplying Bailey retailer.

SPARE PARTS

Spare parts are safety critical parts! For this reason when fitting spare parts in our products we recommend the use of original AL-KO parts or those parts that we have explicitly approved. The reliability, safety and suitability of parts designed especially for our products have been determined using a special test procedure. In spite of constantly monitoring the market we are unable to assess or vouch for other products.

If repair work or servicing is required AL-KO have a large network of AL-KO service centres throughout Europe. A list of service centres can be requested direct if required. Please bear in mind that repairs should only be carried out

by trained and qualified workshops/personnel. To establish the correct spare parts the service centres need the ETI number (spare part identification number).

CHASSIS MEMBERS

The recommended tow vehicle coupling height is 385mm +/- 35mm from the ground to the centre of the ball.



Off road vehicles are exempt from this towball height specification.

Manufactured from high quality steel, the chassis has extra deep sections to provide strength at points of maximum stress. Large elongated holes are punched in the longitudinal and towbar (A frame) members, to reduce weight to a minimum. Each hole incorporates a return flange to maintain the required strength and provide rigidity in the extra deep sections.

The chassis frame is of a bolted construction which, should the need arise, allows replacement of individual parts.

The chassis is hot dipped galvanized. This is regarded as one of the best forms of corrosion protection. It does, however, require maintenance in certain circumstances. When new, the chassis is of a bright and shining appearance. As the galvanizing cures during the initial 2- 3-month period, this will gradually change. During this curing period the surface should be protected to avoid possible wet storage stain, a soft, light coloured, porous, oxidation layer. If the chassis members are in contact with any salt deposits from roads they should be washed off immediately with a high pressure washer. Salt attracts moisture allowing the surfaces to remain wet. This prevents curing and also allows formation of wet storage stain.

It is recommended that the chassis be washed off, using a pressure washer, on an annual basis (particularly after winter usage) to avoid undesirable build up of salt and dirt deposits. The galvanized chassis should not be painted or subjected to any other protective treatment. Should the galvanizing become superficially damaged exposing the steel core, then it should be cleaned and treated with a cold galvanizing spray.

Damage to chassis members through impact etc. must not be straightened or welded. Damaged chassis members must be replaced.

DRILLING OR WELDING OF PARTS OR ACCESSORIES



This chassis is designed and built to precise tolerances and must not be drilled or welded.

INDEPENDENT SUSPENSION

The AL-KO rubber suspension is designed and developed to suit all types of road conditions and is maintenance-free. Three rubber elements are contained within a hexagonal axle tube. These provide suspension and have inherent damping characteristics. (Only the hubs and wheel brakes require attention, see axle booklet Part No. 580458.)

COUPLING HEAD

The ball couplings are entirely automatic in operation and designed for one-hand operation to suit the 50mm international ball recommended by the British Standards Institution, National Caravan Council and the Society of Motor Manufacturers and Traders.

BRAKE DRUM/HUB ASSEMBLY

The Euro Axle fitted to your Bailey caravan comes complete with maintenance-free wheel bearings greased and serviced for life. Adjustment is not required during the design life of the sealed bearing (100,000 km).

If replacement of the brake drum or shoes is required, this must be carried out by authorised AL-KO Service Centres. Specialist tools and equipment are required. The rear hexagonal bolt covered by a black plastic cover must NEVER be touched.

TRACKER MONITOR AND CARAVAN ALARM

Dependant upon model, your caravan may have been fitted with a TRACKER Monitor and Caravan Alarm.

Using VHF technology, the police can track a stolen caravan even if it's being transported or hidden in a lock-up or a shipping container.

ALARM OPERATING INSTRUCTIONS

The Caravan Alarm system detects external caravan movement such as shaking and tilting, lifting and towing. Internal movement is detected by a passive infrared sensor (PIR).

If the alarm is triggered, the siren will sound. The TRACKER Monitor system, once armed via the remote control, detects caravan motion. If the TRACKER Monitor system is triggered, TRACKER will be alerted. TRACKER will call you and, if there has been a theft, start the recovery process.

TRACKER Monitor requires a setting period of 2 minutes before becoming fully operational. Should the alarm not be armed or not be operational at any point (e.g. as the result of a flat remote control battery), the TRACKER Monitor system will still continue to operate for tracking and recovery purposes but no automatic alert will be given to TRACKER.

To ARM

Press the button on the remote control once and the siren will beep twice.

After 45 seconds the alarm will be armed. The siren will be triggered if the caravan is towed, moved, tilted and lifted onto the back of a trailer.

The siren will sound for five minutes unless stopped by the user. The siren can also be triggered by the passive infrared detector (PIR).

To DISARM

Press the button on the remote control once. The siren will beep once and the alarm will disarm. If already sounding, the siren will be silenced.

The alarm is supplied with one PIR and two remote control units. Additional units may be ordered from your Bailey retailer.

WINTER STORAGE

Before storing the caravan for winter, please ensure that the leisure battery is fully charged. Dependant on the battery's capacity and age, it will require recharging at intervals of between three and six months.

What do I do if my caravan has been stolen?

Report the theft to the local police authority then contact TRACKER on the theft line. On confirmation of the theft details, the Tracker system will be activated and the police will start to track your caravan. Once the police have located your caravan TRACKER will arrange for a uniformed guard to stay with it until TRACKER recovery partners arrive to pick it up and return it to you.

I am changing my caravan and the new one does not have a TRACKER system, can I take it out and fit it to my new one?

No, it is not possible to transfer it to another caravan.

Will my TRACKER system work in France?

Yes the TRACKER system works in England, Scotland, Wales, Northern Ireland, France, Spain, Portugal, Italy, Netherlands, Luxembourg and Poland

What happens to my TRACKER unit if my caravan battery is disconnected?

The alarm part of the TRACKER Caravan system is powered from the leisure battery so it will not operate if the leisure battery is disconnected. The TRACKER Monitor system has its own external 12 volt supply that will last up to 6 months with the leisure battery disconnected but it is advisable to keep the leisure battery connected and charged at all times

Can I have a second PIR fitted?

Yes, you can have any number of PIRs fitted. They will need to be programmed to your alarm, please refer to your Bailey retailer.

Does the PIR cause the Tracker system to go off?

No, the PIR will only make the siren sound. It will NOT trigger the TRACKER system.

The PIR has a red light on it, can I switch it off?

No, the warning LED indicates that the unit is working and cannot be switched off. The PIR is permanently active as indicated by the periodic flashing of the red LED. However, the alarm will only trigger if it is in the armed state.

I keep dogs in my caravan and the alarm keeps going off, can I switch off the PIR?

No, this is not a feature of the system and will always be working if you have armed the alarm.

The PIR is making a funny noise why?

The PIR has a low battery warning tone. If this is sounding, the batteries require replacement.

What battery is in the PIR and where can I get one?

It uses 2 x AAA batteries. These are commercially available.

I pressed the remote control button and nothing happened. Why?

Did the small red light on the remote control illuminate? If not try changing this battery with a GP23A type battery.

Have you got your leisure battery connected and charged? If not, charge the leisure battery for over 24hours.

What battery do I need for the remote control?

GP23A type battery. These are commercially available.

I have lost my remote control. What can I do?

You will need to contact your Bailey retailer to purchase a replacement remote control. They will de-program your old remote from the alarm (it will then not work again) and at the same time re-program the alarm to the new, replacement remote control.

I only have one remote control. Can I obtain more?

Yes, your Bailey retailer will be able to sell you an additional remote. Up to 5 can be programmed and linked to the system.

My Bailey caravan does not have a Tracker fitted to it can I have one retrofitted?

Yes, your Bailey retailer will be able to sell you an after-market Tracker system.

WATER SYSTEMS: WITHOUT AN ON-BOARD WATER TANK

WATER SUPPLY

Various models are supplied with a 12v submersible pump, controlled by a pressure switch. This pump is designed to simplify the connection of an outside water supply to the caravan system. The pump comprises of a wall socket, plug, hose and submersible pump. The plug and socket combine both the water and electrical connections and are designed for pumping fresh water into the caravan.

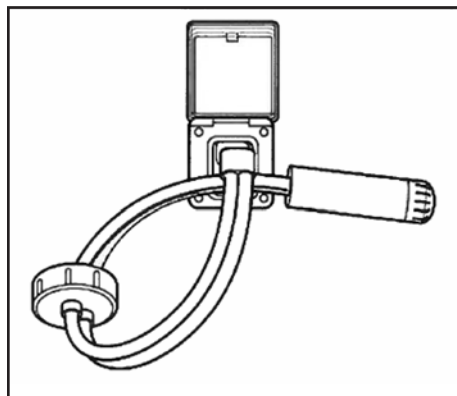

DRAIN VALVE

Near to the water heater within one of the front bunks you will find the drain valve (pictured below). This valve is used to drain your caravan of all water prior to being in transit.

Before attempting to fill your water system you should always ensure the yellow switch is in the horizontal position (position e). When you wish to purge the system of water (prior to being in transit) you should place the yellow switch in the upright position (position f). The water system will now purge any excess water.

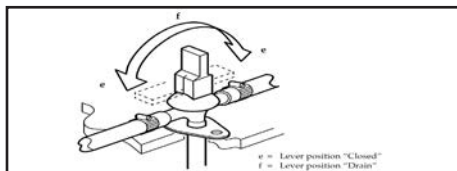

SETUP

1. Open one cold tap (e.g. the kitchen sink).
2. Place the pump into the aqua roll (pictured below).

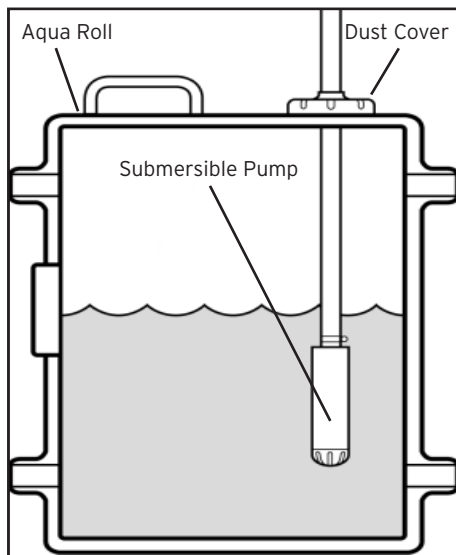

3. Insert the plug end of the pump into the wall socket and close the flap to lock plug in place (pictured below)

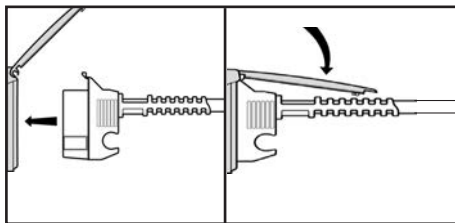

4. Fit the dust cover over the opening in the aqua roll (the dust cover should not be air tight to the water container as air must be allowed to enter the container to replace the water being pumped out).
5. Switch on 12 volt supply at the main control panel (isolator switch inside caravan).
6. Water will flow from the open tap expelling any trapped air in a few seconds.
7. Turn off the tap.

REMOVING THE PUMP

- Switch off the 12v supply at the control panel (isolator switch inside caravan).
- Pull the plug from socket.
- Shut the flap.



Do not run pump dry or use the pump in water temperatures above 40°C (100°F)

It is best practice to stand the pump vertically in the tank.

ROUTINE MAINTENANCE

The micro-switch or phosphor bronze contacts can be removed for inspection or replacement.

Ensure the hose adaptor O-ring and the socket in the housing are kept free from dirt.

Use only silicone or water-based lubricant on the inlet nipple O-rings on the socket.

Service the inlet socket annually.

ECOCAMEL**Making showers better**

Proudly powering your Bailey Caravan shower experience
www.ecocamel.com

**WATER SYSTEMS:
WITH AN ON-BOARD WATER TANK**

WATER SUPPLY

Various models are supplied with an on-board water tank and inbuilt submersible pump as well as an external 12v submersible pump controlled by a pressure switch. The external pump can be used to supply water directly to the caravan from an outside water supply or it can be used to fill the on-board tank in the same way as described in the previous chapter.

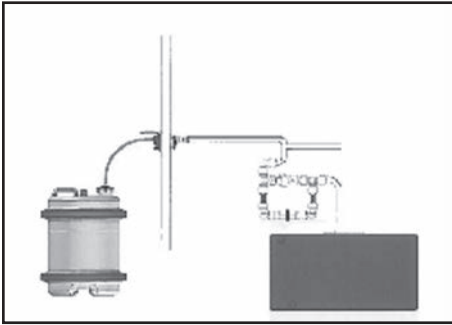

FILLING THE ON-BOARD TANK

1. Complete steps 1-7 on the previous pages.
2. Switch off the 12v supply for the on-board pump at the main control panel.
3. Locate the 2-way valve in one of the front bunks. See below.

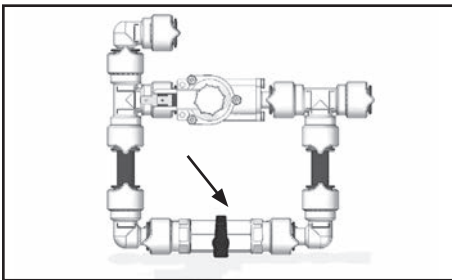

4. Turn the 2-way valve to the open position shown below.

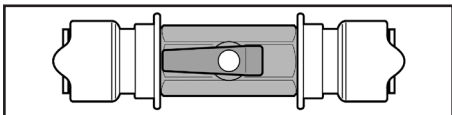

5. Switch on the 12v supply for the external pump at the main control panel (EXT). This will fill the on-board tank.
6. When the water runs from the overflow pipe below the caravan, switch off the 12v supply for the external pump at the main control panel.
7. Return the 2-way valve in the front bunk to the closed position shown below.

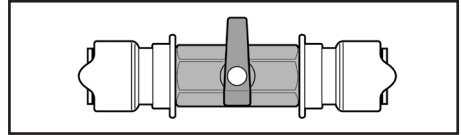

INTERNAL SUPPLY

1. Open one cold tap (e.g. at the kitchen sink).
2. Locate the 2-way valve in the front bunk.
3. Ensure the 2-way valve is set to the closed position shown below.

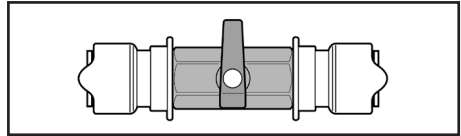

4. Switch on the 12v supply for the on-board (INT) pump at the main control panel. Water will flow from the open tap expelling any trapped air in a few seconds.
5. Turn off the tap, the system is now ready for use.



Do not run pump without water or use the pump in water temperatures above 40°C (100°F)

The pressure switch is sensitive to drops in battery voltage. As the voltage falls, should the switch need adjustment, turn it anti-clockwise. Rotary switch shown below.

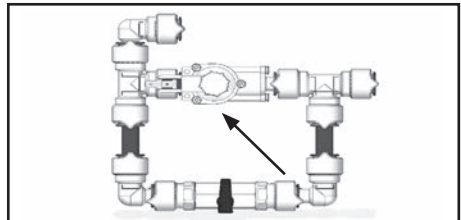

TANK DRAIN OPERATION



The tank must be drained completely prior to travel.

1. Locate the 2-way valve attached to the side of the on-board tank.



2. Turn the 2-way valve to the open position shown below.

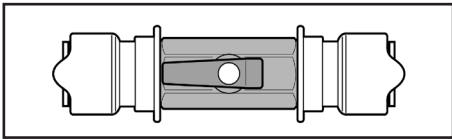

3. The water will drain from the tank beneath the caravan.
4. Once all the water has been drained turn the 2-way valve to the closed position shown below.

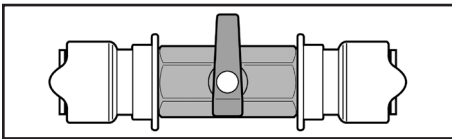

To fully drain the water system see previous section entitled 'Drain Valve'.

DRAINING AND WINTERIZATION OF THE WATER SYSTEM

Bailey caravans may be in use all the year round, however, when not in use (even for short periods) this procedure should be followed.

One night in freezing temperatures is all that is required for expensive, permanent damage to occur within the water system.

Ensuring that all water is removed from the caravan's pipework, taps and appliances will reduce the risk of frost damage occurring. Frost damage can occur when water left in the

system freezes and expands. This causes the pipework to split, crack or burst.

PROCEDURE

1. Ideally position the caravan so the drain valves are the lowest point, e.g. tilt the caravan.
2. Switch off the 12v supply for all pumps at the main control panel.
3. Open all taps/mixers to the mid position, including the external shower (if fitted).
4. Remove the shower handset (including the external shower if fitted) and shake the water out.
5. Open the water heater drain valve and leave open.
6. Open the on-board tank drain valve (if present) and leave open.
7. Where grey waste tanks are fitted, remove all sink plugs and open the drain tap.
8. Open all other drain points (if present).
9. External water components - shake water out of pump/aqua-source and store inside the caravan.

The shower tray cannot be expected to drain fully, some residual water may remain which will require 'mopping up'.



It is essential that the level of ceramic ball mixer taps is fully raised and in the central position. Failure to do this will not allow both the hot and cold water system to fully drain and will result in frost damage.



Frost damage cannot be claimed under warranty.

ON INITIAL SETUP AFTER WINTERIZATION

- Check all the plumbing connections.
- Sterilise the water container and flush the system through with a sterilising fluid.
- It is recommended that the water system is checked during the annual caravan service.

STERILISING

When cleaning the water system at the start or end of the season it is advisable to use non-chlorine-based sterilising fluid.

Flush the system thoroughly to remove the effective fluid traces.



Bailey states that you must fully drain down all fluids before travelling (with the exception of the central heating system). Any fluids within the caravan whilst travelling will effect your payload allowance.

WATER SYSTEM TROUBLESHOOTING

FAULT	CAUSE	POSSIBLE SOLUTIONS
Pump will not run	No power to pump	Check power supply Check the mains isolator switch is on Check the pump isolator switch is on
	Fuse has blown	Replace fuse (do not exceed recommended fuse size)
	Blockage in pipework	Check pipework for kinks Check pipework for blockage
Pump runs but no water appears	No water available	Check water tank is not empty Check filter cap is not blocked
	Water leaking from system	Check pipework and connections for leaks and repair as necessary Check water system drain plugs are closed
Pump runs but will not switch off	Water leaking from system	Check pipework and connections for leaks and repair as necessary Check water system drain plugs are closed
	No water available	Check water tank is not empty Check filter cap is not blocked
Pump cycles on and off periodically when all the taps are closed (normal with partially opened tap)	Water leaking from system	Check pipework/fittings for leaks and repair as necessary Check water system drain plugs are closed
	Pressure switch	Check pressure switch settings
	Power supply to pump	Check battery is not discharged
Low flow	Blockage in pipework	Check pipework for kinks Check pipework for blockages
	Power supply to the pump	Check battery is not discharged
	Pipework/connections crushed due to over tightened jubilee clips	Replace damaged connections
	Water leaking from system	Check pipework/fittings for leaks and repair as necessary Check water systems drain plugs are closed

ADJUSTING YOUR PRESSURE SWITCH

Your pressure switch is factory set and should not normally require adjustment. However, if adjustment is required due to the power supply voltage varying from the previous setting, either because of battery drainage or higher voltage being supplied when the battery charger is operating or in the event that your pump doesn't switch off when you close the taps or pulses on and off rapidly when the taps are fully open.

You should follow the below guidelines to re-adjust the pressure switch setting.

Which Pressure Switch do you have?

In-Line Pressure Switch

Internally located within the water system pipework

Integral Pressure Switch

Located on the back of the water inlet socket



Pressure Switch Setting

Ensure the system, including the heater is full of water and all taps are closed. Refer to your user manual.

Tighten the adjusting screw clockwise until the pump comes on. (For integral socket based pressure switches, first loosen the pressure switch locknut in an anti-clockwise direction.)

Open any tap until you have a smooth flow of water, then close the tap. You should hear the pump running and the pump running light if fitted will be on.

Return to the pressure switch and turn the pressure switch adjustment screw slowly anti-clockwise until the pump has stopped. Turn the screw a further half turn (180 degrees) anti-clockwise.

Check for correct operation by opening and closing all taps individually. The pump should turn on when the cold tap is opened and switch off immediately when the cold tap is closed. NB. There will normally be some pulsations at low flows.

The hot side may take about 10 seconds to react (both on and off) due to cushioning effect in the water heater.

For integral socket based pressure switches, carefully tighten the locknut until it is tight keeping the adjustment screw in position.

THREE GOLDEN RULES:

1. NEVER allow the pump to run dry
2. NEVER allow the pump to run continuously for more than 15 minutes
3. The pump assembly **MUST** be unplugged **BEFORE** putting the pump back into the refilled water container.

If setting of the pressure switch is still not correct you may experience:

Pump running continuously, even with tap closed. If undiscovered, could result in pump failure and flat battery. Most likely causes are that present voltage is significantly lower when last adjusted, or water container is empty.

CURE: Re-adjust switch or refill container

Pump does not run at all. If not due to blown fuse or faulty connections, then most likely cause is excessive continuous running (see above) **CURE:**

Replace pump and re-adjust switch

Pump runs intermittently ON, OFF, ON, OFF etc. Seen as pulsing flow from tap, or as inability to set constant water temperature, water goes hot, cold, hot, cold instead of constant warm. Most likely cause is that present voltage is significantly higher than when last adjusted.

CURE: Re-adjust pressure switch, if problem persists add a Whale Surge Damper (WS7205).

Pump runs very noisily but does not pump water. Likely to occur after water container has been refilled. Pump is air-locked and is fighting to get air out and water in.

CURE: Unplug from the socket, allowing pump to flood, and reconnect by plugging in again.

The correct sequence when refilling the container is to unplug, put pump into container, then reconnect.

Pump continues to run for up to 30 seconds after tap is turned off. This is not a problem. This is a characteristic of pressure switch systems caused by the dampening effect of the hot water heater or surge damper on the cold side.

If after following these procedures the system continues to pulse when all taps are closed there may be a leak in the system.

Please contact Whale Support for further guidance.



LAMILUX COMPOSITES

*Fibre-reinforced composites -
the high-tech material for roofs, walls and floors*

Long lasting, very light and strong, especially resistant to damage from hail and minor impacts, whilst also being resistant against corrosion. Fibre reinforced composites are the ideal facing sheets for the sandwich panel

elements used in the construction of all areas of caravans and RVs, whether the external or internal walls, floor or roof - fibre reinforced composites from Lamilux are technical and visual highlights.



LAMILUX GRAPH
for the inner wall

LAMILUX HG 4000
for the outside wall

**LAMILUX
SUPER PLUS MATT**
for the inner wall



All tests certified in compliance
with **TÜV Süd** quality

TÜV SÜD certified quality



SALES REPRESENTATIVE IN GREAT BRITAIN:

GRP Marketing Ltd. | Nick Guscott | Tel.: +44 (0) 798 083-5431 | E-mail: nick@grpmarketing.com

LAMILUX COMPOSITES GMBH

Zehstraße 2 | 95111 Rehau/Germany | Tel.: +49 (0) 92 83 595-0 | Fax: +49 (0) 92 83 595-29 0 | E-mail: information@lamilux.de

WWW.LAMILUX.COM



Morland™
FIT OUT PRODUCTS

Morland proudly supplies Bailey

Interior Panels, Profiles & Flooring

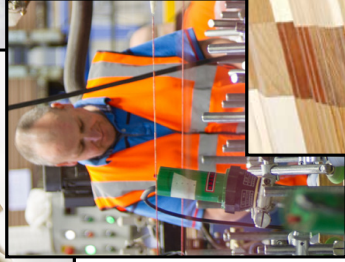

Morland, Unit 2,
Buttington Cross Enterprise Park,
Welshpool, Powys, SY21 8SL

Tel: +44 (0)1938 551 980
www.morland-uk.com

THE GAS SYSTEM

All gas appliances fitted within your Bailey caravan are suitable for operation on both butane and propane without the need for adjustment. However gas type specific regulators must be used.

GENERAL INFORMATION

Gas cylinders: Bottled Liquefied Petroleum Gas (LPG) is the most convenient portable source of fuel for your caravan.



The gas system meets BS EN 1949:2011 and should only be modified by a qualified person.

Never use portable cooking or heating appliances, other than electric heaters that are not the direct radiant type. Direct radiant types are a fire and asphyxiation hazard.

TYPES OF GAS

BUTANE

- Butane is supplied in the UK in green or blue bottles.
- Continental bottles usually have a male left hand thread similar to but not identical with UK Butane.
- Butane is suitable for use at temperatures down to 2°C but will not work below that temperature.

PROPANE

- Propane is supplied in red, or partially red bottles that have a female left hand threaded connector.
- Scandinavian countries use the same connector.
- Germany and Austria supply propane with a male connection.
- Propane will work at temperatures as low as -40°C and is therefore suitable for all winter caravanning.

SAFETY

- Make sure that heating, cooking appliances and gas cylinders are switched off before you move the caravan.
- All gas appliances in your tourer can have their gas supply individually isolated by turning off the relevant tap. The taps are located either on the centrally positioned gas manifold or directly beside the appliance. The manifold will look similar to the adjoining picture.

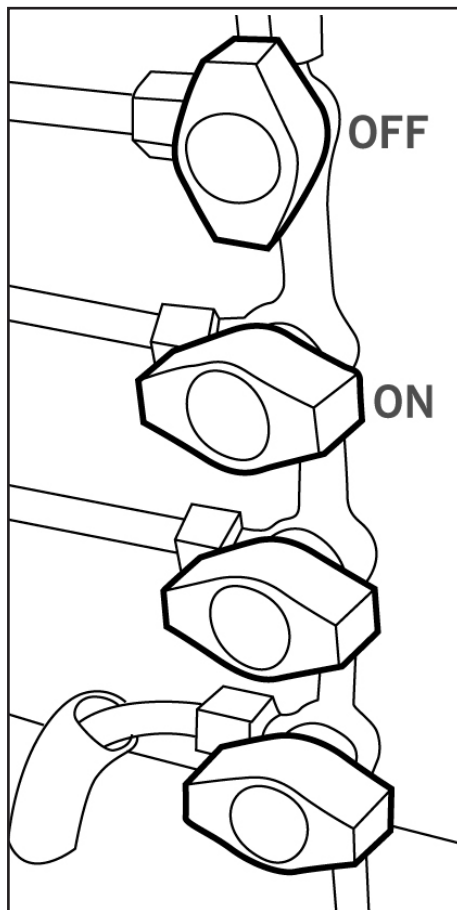

Regularly check flexible gas hose, joints and connections for tightness.

Finally make sure that each gas appliance is working efficiently to the recommendations of the appliance manufacturers.

THE REGULATOR

The regulator is a governing device which adapts the bottle pressure to one that suits the equipment in the caravan.

Your caravan is fitted with a regulator as standard. This is located in the caravan gas box. The gas regulator has a working pressure of 30m bar and is suitable for both propane and butane liquefied petroleum gas. There are dedicated hoses available for different types of gas bottle.

PLEASE MAKE YOURSELF AWARE OF THE FOLLOWING



Some industrial LPG appliances operate at high pressure and require a "high pressure" regulator. This often has an adjusting handle on it. Never use such a regulator on a caravan.

- Propane and butane gas regulators are not interchangeable.
- Always ensure that the gas system is inspected/maintained every 12 months.
- In the event of a fire ensure all occupants evacuate the caravan via the nearest escape route.
- If you suspect a gas leak then immediately turn off the supply of gas, then turn off the gas valve on the gas bottles. When this has been completed the system must be inspected by a qualified person.
- Never use gas bottles located outside the caravan gas box.
- Do not use any gas extension hoses.
- When using a gas barbecue always ensure gas appliances are suitable for use at 30mbar.

CHANGING GAS CYLINDER

1. Ensure the cylinder is empty.
2. Turn off the regulator tap located near to gas regulator.
3. Turn off cylinder valve and all gas appliances.
4. Remove the gas hose regulator from the cylinder.
5. Release retaining strap.
6. Remove cylinder from gas locker and stand on ground.
7. Fit plastic protective cap to the cylinder.
8. Before placing the full cylinder in the cradle ensure that the tray is clean and free from any debris. Cleaning should be carried out with only warm soapy water.
9. Place cylinder in the cradle within the gas locker.
10. Remove plastic protector from cylinder.
11. Connect the gas hose.
12. Connect retaining strap.
13. Turn on cylinder valve and systematically relight appliances as required.

GAS SAFETY ADVICE



LPG is poisonous. There is a danger of death if all air and oxygen is excluded. Ventilation holes must be kept clear at all times and must not be obstructed. Manufacturers have given LPG a distinct smell in order to identify leaks.

GAS LEAKS

If the smell of gas becomes apparent, the supply should be turned off at the cylinder immediately.

Extinguish naked flames including cigarettes and pipes.

Do not operate electrical switches.

Open all doors and windows to disperse any escaping gas.

Butane/propane gas is heavier than air; any escaping gas will therefore collect at a low level. The strong unpleasant smell of gas will enable the general area of the leak to be detected.

Check that the gas is not escaping from an unlit appliance. Never check for leaks with a naked flame. Leak investigation should be carried out using a leak detector spray.

Do not operate any electrical apparatus whatsoever, especially light switches. If the leak is not obvious, the caravan should be evacuated and a competent service engineer consulted.

Avoid naked lights when connecting or changing a cylinder. Ensure the gas valve is turned off.

Regularly inspect the flexible gas hoses for deterioration and replace as necessary with approved hoses (all hoses should be replaced before the expiry date marked on the hose or after a maximum of five years).

Keep gas bottle containers outside (and protected against frost). If they must be kept inside make sure they are well away from heat.

VENTILATION

All ventilation comply with EN 721. Vents should not be obstructed in any manner as this could lead to insufficient ventilation. In this case the atmosphere becomes depleted of oxygen which leads to the formation of the highly poisonous gas Carbon Monoxide. Carbon Monoxide is odourless, colourless and tasteless and could rapidly cause unconsciousness leading to death with little or no warning prior.



Under no circumstances should the caravan's ventilation be blocked or obstructed in any way.

High level ventilation is via the roof lights. Low level ventilation is via the vents in the floor in the caravan living area. With multi-berth layouts the rear sleeping compartments have their own low level ventilation. Please consult your caravan retailer for its location.

The mesh screens fitted should be kept free of obstructions by dust, leaves, insects etc. Inspect regularly and use a brush and soapy water as necessary. It may be necessary to remove the weather shield located on the underside of the floor of the caravan to gain access for cleaning.

All flue installations should be inspected once a year, throughout their life, for corrosion. Flues should be replaced if any sign of degradation is found. Ensure that the replacement is of an approved type. Check that the external seal is seating correctly and the locknut is fully tightened.



Do not make any additional openings in the floor.



Appliances such as cookers with naked flames should never be used for room heating.



No appliance shall be used inside when being connected to the external BBQ socket.

GAS BBQ POINT

The external gas BBQ point should never be used as a gas inlet it should only ever be used as a connection outlet.



Please be aware that contaminated gas will cause regulators to become damaged and fail. Any such failure caused by contaminated gas will not be covered by your warranty.

THE 230v ELECTRICAL SYSTEM

As in the home, care must be exercised when using mains electricity.

UPON ARRIVAL AT CARAVAN SITE

When connecting the caravan installation to the mains supply:

1. Check the mains supply is suitable for your installation and appliances.
2. Check that your installations will be properly earthed.
3. Never accept a supply from a socket outlet or plug having only two pins, or from a lighting outlet.
4. Check that any residual current device (RCD) or earth leakage circuit breaker in the mains supply to the caravan has been tested within the last month. After connection to site supply, test again.
5. Make sure that the switch at the site supply point is off.
6. Make sure that the caravan RCD unit is switched off.
7. Remove any cover from the electricity inlet provided on the caravan, and insert the connector of the supply cable.
8. Remove any cover from the socket outlet provided at the site supply point, and connect the plug at the other end of the supply cable.
9. Switch on the mains switch at the site supply point.
10. Switch on the caravan RCD unit.

In cases of doubt, consult the site owner or their agent.

UPON LEAVING THE CARAVAN SITE

1. Switch off the site supply.
2. Switch off the caravan RCD unit.
3. Disconnect the pitch lead.
4. Replace the cover of the socket outlet at the site supply point. It is dangerous to leave the supply socket or supply cable live.

If you encounter difficulty, consult an approved electrical installation contractor (which may be the local electricity board). It is dangerous to attempt modifications yourself.

Every 12 months, the caravan electrical installation should be inspected, tested and a report on its condition obtained as prescribed in the Regulations for Electrical Installations, published by the Institute of Electrical Engineers.

OVERSEAS CONNECTIONS



Connection to a mains voltage supply overseas requires particular attention.

- Care must be taken when connecting supplies abroad since the supplies can be reverse polarity.
- The significance of reverse polarity is that when equipment is switched may not be electrically isolated.
- The only certain way of making equipment safe is to unplug it.
- A means of checking the polarity of the mains supply when overseas is useful.
- There are several proprietary makes of equipment available for this purpose. If it can be achieved, it is preferable to connect live to live, and neutral to neutral to maintain full electrical protection.
- Check all caravan equipment is set up to accept the site supply before actually switching on.

MAINS UNIT (PDU)

The mains unit replaces the conventional fuse box.

The unit gives overload and earth leakage protection for the 230v electrical supply in your caravan.

FOR NORMAL OPERATION

- All switches on the unit need to be set to the ON position. The switches on the left of the unit are known as MCBs (miniature circuit breakers). These take the place of the conventional fuse and are more convenient.
- In the event of a fault the MCB trips/ automatically moves to the OFF position.
- After elimination of the fault the MCB can be re-set by switching to the ON position.
- If an earth fault develops or a person was to touch a live piece of equipment the leakage of current to earth should immediately operate the RCD (residual current device) and "trip" the main switch, to the OFF position.

- This switch is only resettable after elimination of the fault.
- To re-set, operate the switch as for MCBs every time you connect to a site supply the RCD should be checked by operating the test button marked "T". The unit should immediately switch to the OFF position. If the unit does not switch off then a qualified electrician should be consulted.

If the unit does switch off, the test is complete and the switch can be reset restoring the supply back to normal.



Having too many appliances switched on at the same time will trip the MCB. This is a safety measure.



It is essential that connections are made exactly as shown. If terminal markings are not in accordance with the diagram they must be ignored. If in doubt consult a qualified electrician.

It is possible that all of the 230v mains electrical equipment may not be operated simultaneously. A typical UK caravan park mains hook-up point provides a maximum output of 16 amps and on some continental sites the available output may be as low as 5 amps. If your loading exceeds the site supply it may trip the park's circuit breaker.

Please check the available mains output with your site operator.

The following items need to be added together if used simultaneously.

230V mains equipment typical consumption figures:

Fridge	0.5 amps
Colour TV	2.5 amps
Charger	1.0 amps
Microwave	10.0 amps
Air conditioning	4.0 amps
Blown/convection air heating	8.7 amps

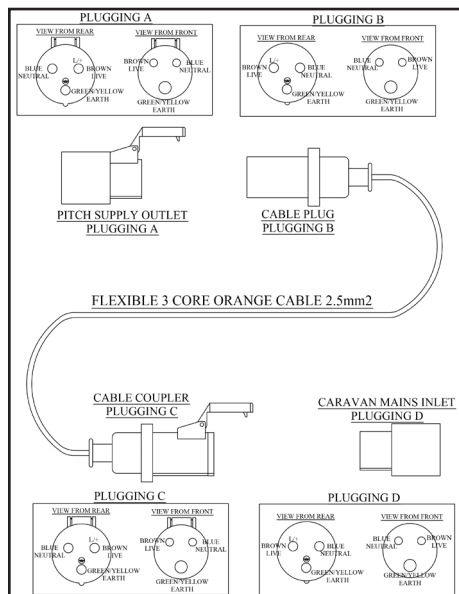

Always disconnect the electrical connector between the towing vehicle and the caravan before connecting a 230v supply to the caravan and before charging the caravan battery.

THE 12v ELECTRICAL SYSTEM

Your caravan is fitted with a 12v charger as standard. This converts the 230v AC supply into 12v DC. It enables the 12v equipment in the caravan to function and also charges the caravan leisure battery when plugged into a site hook up. A fully charged caravan leisure battery should read 13.8 volts on the voltmeter mounted in the control panel. The charger is capable of charging leisure batteries and will not overcharge.

The 12v system is designed to operate with a leisure battery in circuit and should not be turned on without one connected.

The 12v supply to the caravan services can be isolated via the 12v on/off switch on the control panel.



The battery must be placed in the tray provided in the battery storage compartment.

A battery of not less than 40-50 amps/hours capacity is recommended. Crocodile clips should never be used to connect the battery, and terminals should be shrouded. Always switch off all appliances and lamps before disconnecting the auxiliary battery.

- The battery should be secured to prevent movement when towing.
- Metal objects should not be stored in the battery box.
- Where a 12v extension is used between the tow-car and caravan, this should not exceed 5 metres in length- minimum cable size 2.5mm to minimise voltage drop.
- DIY modifications/additions to the wiring systems are not recommended. Always consult your retailer who will carry out such work.
- Do not continuously charge the battery when the caravan is not in use.



Negative connections should always be disconnected first and reconnected last.



Car type battery chargers are not suitable for charging a leisure battery and may damage it.



When not using the caravan always ensure that the fridge control is turned to the 'off' position. Failure to do this will result in a flat battery due to 12v power drain from the fridge circuit relays.

BATTERY BOX CONNECTIONS

Certain models are fitted with a 12v external solar panel connection point. This can be found on the side of your van.

Certain models also feature a connection for a free standing external satellite dish. This connection is located within the external 230v socket.



Any replacement of an auxiliary battery shall be of the same type and specification as originally fitted or as specified by the manufacturer.

CBE CONTROL PANELS

CBE control panels consist of separate switching blocks.

12V AND PUMP CONTROLS (SINGLE AXLES)

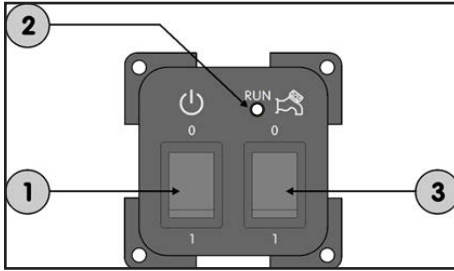

1. 12v main switch: 0 = OFF, 1 = ON.
2. LED "pump run": this LED is lit (yellow) when the pump is actually running.
3. 12V water pump switch: 0 = OFF, 1 = ON.

12V AND PUMP CONTROLS (TWIN AXLES)

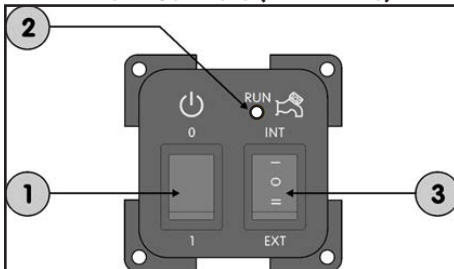

1. 12v main switch: 0 = OFF, 1 = ON
2. LED "pump run": this LED is lit (yellow) when the pump is actually running.
3. 12v water pump switch: 0 = OFF, INT= internal water pump ON; EXT= external water pump ON.

BATTERY VOLTAGE LCD SCREEN

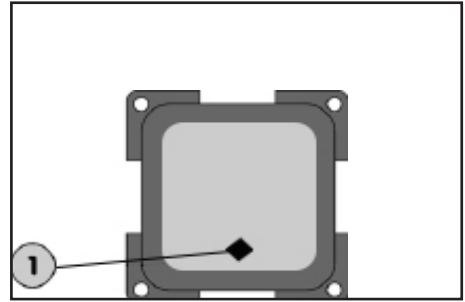

1. Button to check the voltage (in volts) of the connected 12v battery.

Mobile living made easy.

 **DOMETIC**

BE COOLER THIS SUMMER

UPGRADE YOUR VEHICLE WITH A DOMETIC FRESHJET AIRCON



Whether you're seeking the heat of southern Europe or chasing the cool of the Nordics, always take your weather with you. Dometic Freshjet 2200 is a compact, lightweight, quiet air conditioner. Powerful, yet energy efficient, for the perfect indoor climate. It's a great upgrade to your next adventure.

For more information, please visit:
dometic.com/freshjet

DOMETIC FRESHJET 2200

STATUS 570/VP3 DIGITAL ANTENNA SYSTEM

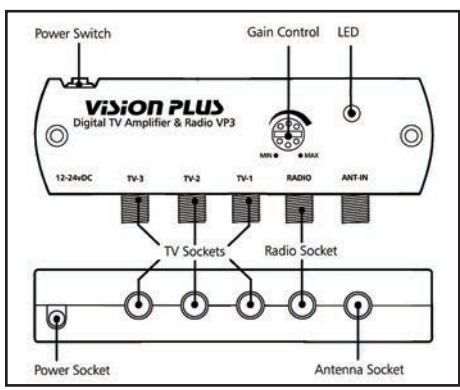

- Frequency Range UHF 470-860 Mhz
- Frequency Range VHF 40-230 Mhz
- Frequency Range FM 88-108 Mhz
- Amplifier Gain Max 18db
- Gain Adjustment 15db
- Flatness +1.5db
- Noise Figure 2db
- Output Impedance 75ohms
- Signal Handling 80dbuv
- Power Supply 10.8-28v DC
- Power Consumption 55ma

TRAVELLING

Do not travel in the following circumstances

- With the antenna raised.
- With the antenna set for vertical signals.

When travelling adjust the antenna so that it points to the rear of the vehicle to reduce the possibility of damage when travelling.

OPERATING

1. Firstly determine the approximate location of the nearest transmitter and whether the signals are horizontally or vertically polarised. For assistance ask your site operator or check other antennas in the vicinity.
2. Loosen the mast locking collar and raise the antenna. Rotate the mast to direct the antenna towards the TV transmitter.
3. The H/V indicator on the bottom of the

4. mast indicates the back of the antenna.
4. Should you need to receive vertically polarised signals, rotate the winder anti-clockwise to tilt the antenna through 90°.
5. DO NOT use undue force on the winder.
6. Switch ON the amplifier and the LED will illuminate.
7. Check the gain control is set to maximum. For maximum rotate clockwise.
8. Tune your television into the strongest signal. You may need to adjust the direction of the mast to achieve the best picture quality.
9. Secure by tightening the mast locking collar.

DAB AND FM RADIO OPERATION

Status is designed to receive DAB and FM when connected to a radio with DAB/FM facility. Dependent on location, DAB and FM reception may be improved by setting the antenna to vertical.

COAXIAL CONNECTIONS

It is critical that all connections in the system are fitted correctly.

GAIN CONTROL

In normal use the button should be rotated clockwise for maximum. In strong signal areas the amplification may need to be reduced. To reduce amplification rotate the button anti-clockwise until picture quality improves. The button rotates through 270° from MAX to MIN.

LED LIGHT

Should the LED on the amplifier not light, firstly check there is power to the unit. Secondly check the polarity is correct. Otherwise contact Grade UK Ltd for further assistance.

SHORT HOOK UP-TEST 1

This test isolates the wiring from the amplifier through to your TV/radio points. Unplug the coaxial plugs from the "TV" sockets of the amplifier and use your TV fly lead with converter 1 supplied. Connect your TV to the amplifier.

Please ensure the antenna dome is plugged directly into the "ANT-IN" socket of the amplifier and switch on. Tune in your TV for the strongest signal. If the picture quality

improves the fault lies with the wiring of the system between the amplifier and TV outlet socket.

SHORT HOOK UP: TEST 2

This test isolates the amplifier by connecting your TV direct to the antenna.

Unplug the antenna from the amplifier and connect converter 2 supplied to the plug on the cable end. Using your fly lead, connect the antenna directly to your TV. Tune in your TV for the strongest signal.

If the picture quality improves, the fault lies with the amplifier.

ANTENNA DOME COAXIAL CABLE

Check the routing of the coaxial cable from the antenna dome to the amplifier. Check to ensure there are no kinks or trapped cable or if there are loops of surplus cable which could affect performance.

Should you still be experiencing difficulties and require assistance, please do not hesitate to contact Vision Plus for further assistance on +44 (0) 115 986 7151

or

Visit www.visionplus.co.uk



It is the responsibility of the caravan owner to make sure that the directional aerial is fully retracted before the caravan is moved. Any damage as a result of neglect, i.e. not retracting the aerial, crash damage, vandalism or incorrect operation will NOT be covered by the manufacturer's warranty.

SOLAR DUAL BATTERY CHARGER SDC 10/20

The solar module generates power when light is cast upon it. The full voltage is also available even if there is little light. The solar automatic charger only serves to charge 12v (24v) lead accumulators comprising 6 (12) single cells (e.g. leisure battery) with a capacity of 50-100Ah (SDC 10) or 50-200Ah (SDC 20). The preferred application fields for the automatic charger are batteries with gel, AGM (absorbed glass mat) or liquid electrolyte.

- The device is not suitable for charging:
- 6v batteries or 6v lead accumulators
 - Non-chargeable batteries
 - Nickel-cadmium batteries

 The device is only suitable for regulating solar modules. Do not connect any other voltage sources (e.g. main voltage 230v) to the device. This may destroy the device, sources or both. If any other voltage sources are used together with the device, please ask your retailer regarding compatibility.

OPERATING INSTRUCTIONS

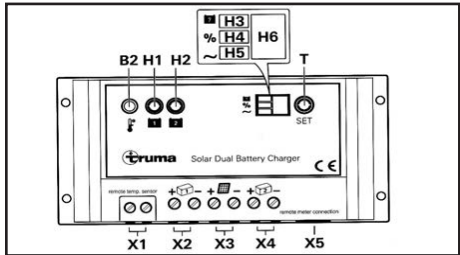

- H1 LED: Function display battery 1
- H2 LED: Function display battery 2
- H3 LED: Battery type- AGM, gel, liquid
- H4 LED: Charging current distribution
- H5 LED: PWM charging frequency
- H6- shows the values of H3, H4, H5 as numbers
- T Query/change operating mode
- B2 Internal Temperature sensor
- X1 Connection for temperature sensor B1
- X2 Connection for battery 1
- X3 Connection solar module
- X4 Connection for battery 2
- X5 Connection (RJ-45) for remote display (optional)

FUNCTION

The device has a modern microprocessor controlled pulse with modulated three-phase charging characteristics. This allows high performance combined with a light weight and small dimensions. By virtue of the high-quality electronics, it works highly efficiently. The automatic charging process preserves the device and does not overcharge the batteries. This in turn extends the service life of the batteries significantly. It is suitable for batteries with liquid, gel or AGM technology and has a settable charging current distribution for two separate battery connections.

The device is designed for continuous operation and parallel mode. Consumers can be continuously connected, switched on or disconnected. Consumers are supplied and the batteries are charged at the same time. The consumer current here should be smaller than the solar charging current otherwise the battery will not charge.

If the device is operated in conjunction with an external temperature sensor for the supply battery (battery 1), the device regulates the charging voltage automatically depending on the battery temperature. This ensures particularly effective and gentle charging of the battery. If an external temperature sensor is not used, the device regulates the charging process based on the internal temperature sensor.

The supply and starter batteries can be charged by connecting one or several solar modules. Please observe the maximum voltage and power consumption values.

CHARGING PROCESS

The device has an electronic reverse voltage, reverse current and solar short-circuit protection. The charging current is only released if the battery is connected correctly and there is enough power available from sunlight. When a temperature sensor is used, charging takes place on a temperature-dependent basis.

BULK PHASE

Charging with maximum available solar charging current until the charging end voltage is reached.

ABSORPTION PHASE

The charging current is kept for a period of 2 hours. At the end of this period, it changes to the float phase.

FLOAT PHASE

The charging voltage is set to 13.8v. The charging current drops to the value necessary to compensate the self-consumption of the battery. Power is still supplied to the consumers. If the consumed current exceeds the available solar charging current, the charging process can no longer be maintained. If the battery voltage drops below 13.3v, the device automatically switches to the bulk phase if there is adequate solar charging current.

EQUALISATION CHARGING PHASE (ONLY FOR AGM AND LIQUID ELECTROLYTE BATTERY TYPE)

The equalisation charging phase serves to compensate the cell voltages and can reduce any sulphation. If the voltage of the battery drops below 11.1v, it is assumed that the battery has deep-discharged. The device is switched to the equalisation charging phase for 2 hours. At the end of this period, it changes automatically to the float phase.

Deep-discharged batteries can be permanently damaged. Equalisation charging cannot repair this. Use a Truma battery monitor to prevent deep-discharging.

PARALLEL MODE

If load current is consumed while the battery is being charged, it is served from the available solar charging current. If the consumed current exceeds the available solar charging current, the device cannot charge the battery. The device starts charging automatically once an adequate amount of solar charging current is available again.

SETTINGS

The display H6 shows different system settings. Press the key (T) to switch between LED H3, H4, H5 and H6. If the key is pressed again, the system starts at LED H3 again.

BATTERY TYPE

The battery type can only be set for battery 1; battery 2 is assumed to be the same battery type.

QUERY

- Press (T) until LED H3 illuminates; the saved value is shown in display H6.

DISPLAY	H6 BATTERY TYPE
1	Gel (pre-setting)
2	AGM
3	Liquid (liquid electrolyte)

Change

- Press key (T) for 5 seconds until the display H6 flashes.
- Press the key (T) to set the required value.
- If the key is not pressed for 5 seconds, the displayed value will be saved and flashing stops.

CHARGING CURRENT DISTRIBUTION

The charging current distribution between battery 1 and battery 2 can be set. The following distributions can be selected.

Query

- Press (T) until LED H4 illuminates; the saved value is shown in display H6.

	BATTERY 1	BATTERY 2
0	0%	100%
1	10%	90%
2	20%	80%
3	30%	70%
4	40%	60%
5	50% (pre-setting)	50%
6	60%	40%
7	70%	30%
8	80%	20%
9	90%	10%

Change

- Press key (T) for 5 seconds until the display H6 flashes.
- Press the key (T) to set the required value.
- If the key is not pressed for 5 seconds, the

displayed value will be saved and flashing stops.

During the normal charging process, the device divides the charging current between battery 1 and battery 2 as set. Once battery 1 is fully charged, all the charging current is fed to battery 2, regardless of the set value. If the voltage of battery 1 drops, the charging process starts again. If only battery 1 is connected, the entire charging current is supplied to this battery regardless of the set value.

PWM CHARGING FREQUENCY

The pulse frequency of the device can be set here. This may be changed to reduce possible interferences.

QUERY

- Press (T) until LED H5 illuminates; the saved value is shown in display H6.

DISPLAY H6	PWM CHARGING FREQUENCY
0	25Hz (pre-setting)
1	50Hz
2	100Hz

Change

- Press key (T) for 5 seconds until the display H6 flashes.
- Press the key (T) to set the required value.
- If the key is not pressed for 5 seconds, the displayed value will be saved and flashing stops.

FUNCTION DISPLAY / TROUBLESHOOTING

LED H2 shows the status of battery 1.

Battery 2 double the values of the 12v- to work out the 24v values

DISPLAY	CAUSE/RECTIFICATION
LED flashes	Check connections from the device to the battery and solar module, ensure that they are connected to the right terminals. Test the fuse, solar module and battery
LED flashes in longer intervals	Battery is fully charged
LED shines	The battery is being charged
LED flashes in short intervals	The battery is not being charged. If necessary, replace faulty battery
LED does not shine	Battery not connected or over-voltage

If this does not solve the problem, please contact the Truma Service.

REPAIRS

Do not repair or modify the solar panel. Please contact your retailer or the Truma Service.

CAUTIONS

- Liquid electrolyte batteries can create explosive gases, so ensure there is adequate ventilation.
- Check the liquid level at regular intervals. Overcharging can damage your battery; check the technical data for your battery.
- Equalisation charging increases the charging voltage; this may damage the consumer. Ensure that all consumers are designed for these voltages.



The official home of Bailey parts and accessories

Look no further than PRIMA Leisure to find everything you need:

- Model-specific products for your new caravan including the PRIMA air awning range designed for your Bailey.
- Official OEM spare parts and upgrades.
- 20,000+ products available to order online or through your local Bailey retailer.



Your new Bailey essentials...

Keep your new Bailey caravan safe, secure and sparkling clean with branded accessories designed for a perfect fit.



Find the full range online or at your local Bailey retailer.



Wheel Covers - Completely seal out draughts in your awning and protect tyres from UV damage.



Hitch covers - Protect your A-frame from the worst of the weather and dirt when pitched on-site.



Security - Bailey-branded secure wheel and hitch locks with matching lifting and levelling equipment.



Towing Covers - Bespoke-fit and handmade in the UK to protect against road grime and window chips.

HEATING SYSTEMS

ALDE HEATING SYSTEMS



Always replace the heat transfer fluid (HTF) in accordance with the antifreeze product's lifespan. If in any doubt, replace the HTF after 2 years.

The corrosion inhibitors found in ethylene glycol antifreeze may not be cross-compatible. When topping up or replacing the HTF ensure the new antifreeze is compatible with the current antifreeze product. Read the product label or contact the product manufacturer for details.

OPERATING INSTRUCTIONS

3020 Compact High Efficiency Boiler

These instructions are approved for the Alde 3020 Compact HE boiler fitted in caravans in accordance with CE 0402 no. SC0653-13 and have the E5 mark for installation in vehicles in accordance with ECE R122, no. 00 001 and R10, no. 04 166, for use in central heating and hot water systems.

The boiler is not intended for use by persons (including children) with reduced physical sensory or mental capabilities, or lack of experience and/or knowledge, unless they have been given instruction or are supervised. The term "specified use" also covers observance of the operating and installation instructions.

The Alde 3020 Compact HE boiler must be installed or repaired by a competent person in accordance with current local regulations. In the unlikely event that your boiler develops a fault, switch off the boiler and contact Alde, or your dealer or installer.

Operating and installation instructions for the Alde control panel are supplied separately.

BOILER DESIGN

The boiler's internal heat exchanger consists of three concentric cylinders: the combustion chamber, the central heating cylinder and the hot water cylinder.

The combustion chamber is made from aluminium and is divided into two halves by a

baffle plate, with the burner head located in the top half and the flue gases venting through the bottom half.

The combustion assembly is fixed to the end of the internal heat exchanger. It consists of the burner, combustion fan, gas valve, air intake, exhaust ducts and gas line.

Two electric heating elements are sealed inside the central heating cylinder, one for 1kW, one for 2kW.

DESCRIPTION OF FUNCTIONS:

GAS HEATING

When gas heating is set to "On" the combustion fan starts to revolve. Once the correct speed is achieved (in rpm), a signal is sent to the PCB (printed circuit board) for the burner to be lit. The gas valve opens passing gas and the ignition module on the PCB generates sparks at the electrode on the burner head.

When the burner ignites a flame supervision device (FSD) signals the ignition module to cease sparking. The burner fires until the boiler or room thermostat reach the set-point.

Should the burner flame go out unexpectedly, the FSD detects this and attempts to reignite (for about 10 seconds), before shutting down and raising a fault code.



Listen carefully to the ignition sequence of the boiler. You should hear the whir of the combustion fan, the clunk of the gas valve then the tick-tick of the ignition module.

ELECTRIC HEATING

When electric heating is set to 1, 2 or 3kW relays on the PCB trip, feeding the 230 v supply to the electric heating elements. These are controlled by the same programme as the gas heating.

DOMESTIC HOT WATER

The combi-type boiler automatically produces hot water. Heat is emitted from the central heating cylinder into the hot water cylinder. If the hot water cylinder is empty the air is heated but no damage will occur. In a good summer lower the desired

temperature on the control panel to around 10°C. The central heating will not circulate (unless the temperature drops to 10°C), but you will still have hot water.

- The boiler must not be switched on if there is no heat transfer fluid (HTF) in the system.
- Always drain down the freshwater system if there is risk of frost.
- You may continue to use the boiler with no freshwater in the system, as required; no damage will occur.
- Always replace the HTF in accordance with the antifreeze product's lifespan.
- If in any doubt, replace the HTF after 2 years.
- Only sterilise the freshwater system with a product suitable for stainless steel.
- Do not place stowage in the boiler compartment.
- Do not position awnings, tents or other enclosures around the flue terminal.
- Do not obstruct the flue. Be careful not to flood the flue when washing the vehicle.
- The gas heating must not be used when refuelling the vehicle at the service station or related facility.

Being a combi-type boiler, the Alde 3020 Compact HE has an integrated stainless steel hot water cylinder that holds approximately 8.4 litres of freshwater.

The boiler can produce around 12 litres of 40°C warm water per 30 mins (at a cold water temperature of 10°C). If only the electric heating is used, this capacity is slightly reduced.

The hot water should not be used for drinking or cooking.

Always flush out the hot water cylinder before use, especially when it has stood empty for some time.



Any steriliser products should be suitable for use with stainless steel.

Avoid steriliser products containing sodium hyperchlorite as these will cause severe corrosion damage to the hot water cylinder which is not covered under warranty. Read the product label or contact the product manufacturer for details.

When the hot water cylinder is in continuous

use, it should be drained and refilled once a month. This recreates the air cushion in the hot water cylinder that absorbs pressure surges.



If continuously using the hot water cylinder in a hard water area, fit an in-line scale inhibitor to minimise the effects of limescale.

The target hot water temperature is greater than 50°C in normal operation to prevent the growth of Legionella. The hot water will be heated to the maximum achievable temperature at the time. This allows the hot water to achieve disinfection temperatures and increases warm water performance.

If scalding hot water temperatures are a concern thermostatic mixing valves (TMVs) can be fitted.



Alde recommends fitting the 3102-002 high temperature TMV.



Always drain down and completely empty the hot water cylinder when there is risk of frost, unless the vehicle is explicitly stated to be self-winterizing by the vehicle manufacturer.

Failure to drain the hot water cylinder when there is a risk of frost may result in frost damage, which is not covered under warranty.

DRAINING FRESHWATER

1. Switch off the water pump.
2. Open all water taps, showers, etc.
3. Open the safety/drain valve by lifting the yellow tab (Fig.1 [M]) or by turning the blue knob (Fig 1.[K]) 90°.

The system will drain directly below the vehicle.

- Check that all water has emptied out (7-10 litres). Leave the valve in the open position until the next time the hot water cylinder is used.

Check that the breather valve (Fig.1 [N]) is allowing air to enter the hot water cylinder when it is being drained, and that the clear plastic hose is not obstructed.

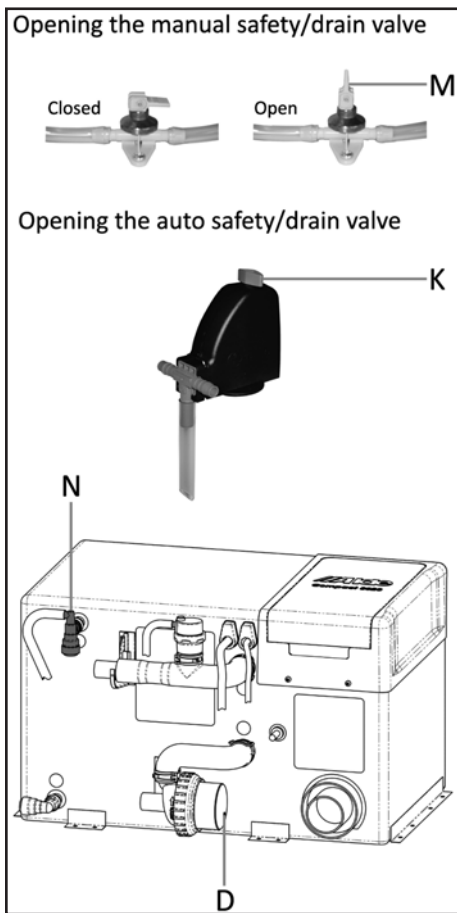

Fig.1

HEAT TRANSFER FLUID

The central heating system is filled with heat transfer fluid (HTF), a solution of 50% ethylene glycol antifreeze and 50% water.



The boiler must not be switched on if there is no HTF in the system.

The antifreeze manufacturer will have a maximum water hardness recommendation. Read the product label or contact the product manufacturer for details.

Alde recommends antifreeze meeting VAG G12++ or G13 specification, and deionised water (0 ppm).

50:50 ethylene glycol antifreeze and water will protect against frost down to -35 to 37°C. A refractometer and/or hydrometer can be used to measure the strength of the antifreeze solution.

Corrosion protection will vary depending on the lifespan of the antifreeze. Contact the product manufacturer for details.



Always replace the HTF in accordance with the antifreeze product's lifespan. If in any doubt, replace the HTF after 2 years.

The corrosion inhibitors found in ethylene glycol antifreeze may not be cross-compatible. When topping up or replacing the HTF, ensure the new antifreeze is compatible with the current antifreeze product. Read the product label or contact the product manufacturer for details.



As a rough guideline, blue and red antifreeze products are not compatible with each other, but VAG G12++ and G13 spec antifreeze (purple/magenta) is compatible with both. Failure to fill with suitable HTF may result in severe damage to your Alde system, which is not covered under warranty.

FILLING

The central heating system is filled with HTF through the expansion tank either by hand or by using the Alde service pump. Any containers used for handling or storing the HTF should be checked first and must be visibly clean to avoid introducing contaminants or foreign objects into the system.

Alde recommends using the Alde 1900-811 or 839 twin-motor service pump to fill the system. To fill the system by hand, unscrew the

expansion tank cap (Fig.2 [R]) and lift the circulation pump (Fig.2 [S]) out of the tank (if applicable).

Carefully pour the HTF into the tank, and repeat until the fluid level is about 1 cm above the MIN mark when cold.

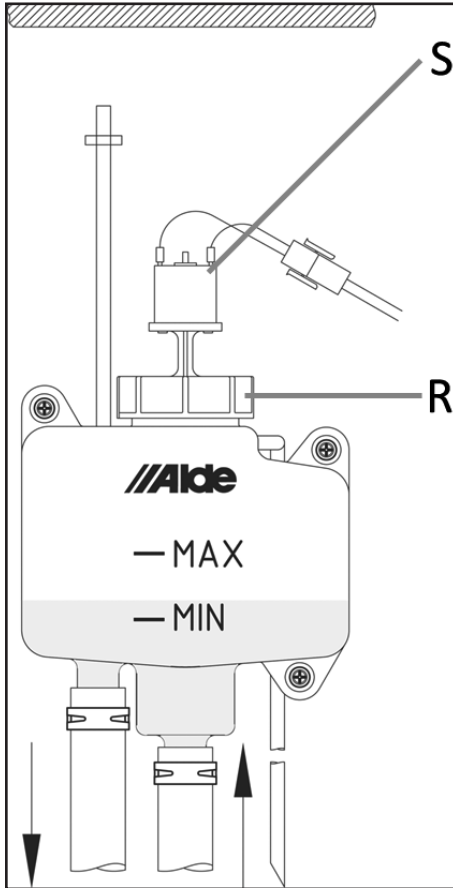

Fig. 2

CENTRAL HEATING

The boiler is set to an upper limit temperature of 85°C, i.e. the temperature of the heat transfer fluid (HTF) as it circulates around the pipes, radiators, convectors, etc.

To ensure the best performance from hydronic heating, air must be able to circulate freely around the back of the furniture (Fig.3). Air vents, cut into the top and bottom of the

furniture must be unobstructed by carpets, cushions, or stowage, etc. The full length of a convector should be ventilated for best performance.



Use gas and electric heating simultaneously for the best performance. The boiler will only use as much energy as is needed, and is 93% efficient on a SEDBUK (seasonal efficiency of domestic boilers in the UK) based test.

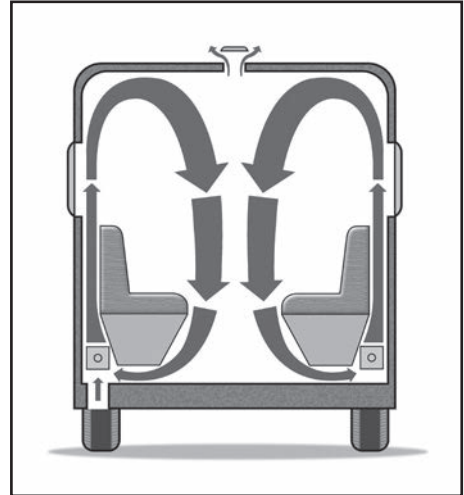

Fig. 3

CIRCULATION PUMP

A pump is used to circulate the HTF around the central heating system.

BLEEDING AIR

The HTF will contain some air. This is unavoidable. Air bubbles can also be introduced when the system is filled.

In a newly filled central heating system you will need to bleed air from the bleed points to ensure best performance. There is an automatic air bleed valve on the boiler. There is also an air vent on the expansion tank.

The installer should fit bleed points elsewhere in the system, especially where the pipes step up and down, and on radiators and towel rails. Air will accumulate at these high points and become trapped.

TO BLEED THE SYSTEM

- Set the temperature to 30°C and select gas heating on the control panel.
- Set the 12v inline circulation pump on the side of the boiler to speed 5 (Fig.1 [D]): see page 62, by turning the blue speed dial clockwise, on the face of the pump motor. NB: Speed is not adjustable if using the 12v circulation pump fitted in the expansion tank.
- After 10 mins, set the pump back to its normal running speed (2 for a caravan, 3 for a motorhome).
- Now power off the Alde 3020 Compact boiler completely, making sure that the circulation pump is not active.
- Follow the flow pipe from the boiler, and bleed the system at each bleed point.
- If Alde bleed points have been fitted, these are metal bleed screws mounted on black EPDM rubber connectors (Fig. 4). Have a cloth in hand. To open, turn the screw anti-clockwise between thumb and forefinger. Air will hiss out. When fluid trickles out, close the bleed screw and mop up fluid with the cloth.



Fig. 4

- Move on to the next bleed point and repeat, until all bleed points have been attended to.

AIR LOCK

If enough trapped air accumulates at one point, an air lock can result and prevent the circulation of hydronic heating.

A ramp or steep slope can be used to raise one end of the vehicle, causing the trapped air to shift around the system. Repeat the full bleed procedure. A caravan can be slowly and carefully tilted to reproduce this effect. To clear a stubborn air lock in under 15 minutes, an Alde-certified service agent can use the Alde 1900-811 or 839 twin-motor service pump.

230v ELECTRIC

The Alde 3020 Compact boiler has two 230v electric heating elements outputting 1050W and 2100W or 3150W combined. Drawing 5A, 9, and 14A respectively (rounded). 230v breakers, fuses, fused spurs and isolator switches should be rated for 16A.

Before using electric heating, check the current limit on the electric supply you are hooking up to.

6A limit, only use 1kW electric heating.
10A limit, use 1-2kW electric heating.
16A limit, use 1-3kW electric heating.

NB: If the electric supply has unstable voltage the amperage will also fluctuate.



Alde recommends fitting the 3010-246 load monitor allowing you to set a limit on the current drawn by the vehicle and the electric heating to automatically accommodate it.

LPG

LPG (liquefied petroleum gas) has two main variants, propane and butane gas. The gas heating in your Alde 3020 Compact boiler can use propane or butane gas as a fuel. Many LPG fuels contain a mixture of propane, butane and other additives.

BS 5482 Part 1 states, 'For butane cylinders, satisfactory service might not be obtained at temperatures of less than 10°C. The most suitable temperature range is from 13°C to 30°C. For temperatures less than 13°C, the use of propane should be considered'.

For this reason, Alde recommends using propane gas for all year round gas heating. LPG cylinders contain both gas and liquid forms. When the cylinder is filled, high pressure transforms the gas into liquid. The liquid reverts to gas when the valve on the cylinder is opened.

LPG is a flammable gas. It can be a fire and explosion hazard if stored or used incorrectly. Store cylinders vertically and securely, to prevent them from toppling.

Do not mount your LPG cylinder horizontally or use liquid phase gas cylinders. Liquid-gas explosion may result. Read the product label or contact product manufacturer for details. LPG is heavier than air. Should a gas leak occur, floor vents in a caravan or motorhome should allow the gas to escape from the vehicle. For this reason, always ensure floor vents are unobstructed.



The boiler compartment contains the gas connection, floor vents and the flue hoses. Do not place stowage in the boiler compartment.

In the event of a gas leak, or if you smell gas:

- Extinguish all naked flames.
- Open all doors and windows.
- Close all gas valves, including the valve on the cylinder.
- Do not smoke.
- Do not operate any electrical appliances or switches.
- Arrange for immediate inspection of the gas system by a competent person in accordance with current local regulations.

LPG from the cylinder is reduced in pressure by a regulator, and is supplied to the boiler at low pressure (30mbar). Never use an unregulated high pressure supply. Where oil and dirt in the gas supply are a concern, gas filters should be fitted to prevent blockage of the boiler gas valve.

NB: Gas heating must not be used while driving your vehicle unless a safety shut-off device is fitted to the gas system. Current local regulations must be adhered to.

FLUE

The burning of LPG produces CO₂ (carbon dioxide), a non-toxic, asphyxiant gas.

Exhaust flue gas can cause possible burns and poisoning. Avoid inhaling exhaust flue gas.



Do not position awnings, tents or other enclosures around the flue terminal.

Air supply is essential for clean combustion. The air intake is located in the flue terminal. For best performance the flue terminal should be well vented. If you are intent on leaving the gas heating unused for a substantial period of time ensure the flue terminal is covered to prevent blockage of the flue.



Do not obstruct the flue. Be careful not to flood the flue when washing the vehicle.



The gas heating must not be used when refuelling the vehicle at the service station or related facility.

MAINTENANCE

There is no manufacturer's service requirement for the boiler itself. The installation of the boiler should be inspected annually for gas safety.

LPG hoses should be regularly checked for signs of damage and should be replaced, at maximum, after 3 years of use.

Bleed air from the system when newly filled, when the vehicle has been standing unused for a period, and before departing on holiday.

The fluid level in the expansion tank should be about 1cm above the MIN mark when cool. The heat transfer fluid (HTF) should be topped up if below this level, to prevent a break in circulation. Only top up with compatible HTF.

Always replace the HTF in accordance with the antifreeze product's lifespan. If in any doubt, replace the HTF after 2 years.

Failure to maintain the condition of HTF may result in frost and/or corrosion damage, and is not covered under warranty.

When the hot water cylinder is in continuous use, it should be drained and refilled each month. This recreates the air cushion in the cylinder that absorbs pressure surges.

WINTER

When camping in the winter always ensure the flue terminal remains unobstructed by snow and ice. Extensions for roof flue terminals and condensate spouts for side flue terminals are available from Alde.

Check the strength of the HTF with a hydrometer and/or refractometer. It should measure 50% ethylene glycol antifreeze or -35 to 37°C.

The central heating can still be used with no freshwater in the system. The air in the hot water cylinder is heated but no damage will occur.



Always drain down and completely empty the hot water cylinder when there is risk of frost, unless the vehicle is explicitly stated to be self-winterizing by the vehicle manufacturer

If camping in temperatures below -10°C, consider carrying spare parts in the event of an emergency. Alde recommends a 12v circulation pump for the expansion tank (with cabling) a PCB, and 4-5 litres of ready to use antifreeze. These spare parts should be kept well insulated and in the warmest part of the vehicle, for example, in the wardrobe near to the expansion tank pipes.

If storing the vehicle for winter ensure the flue terminal is covered to prevent blockage of the flue.

If using the light duty 12v circulation pump in the expansion tank do not leave the central heating on over winter even with a low desired temperature set.



Air the vehicle over the winter without wearing out the light duty pump. Use the programmable Alde control panel to automatically heat the vehicle for 24 hours, once a week.



Only use potable fresh water. Grey water, desalinated water, or water otherwise unfit to drink is not suitable for use as domestic hot water.

TROUBLESHOOTING

The Alde control panel will display messages regarding any error that may have occurred.

The system is completely dead/the control panel is blank

- Check the 20mm T3.15 amp glass fuse in the boiler. This is located under the lid of the black plastic service hatch in a green plastic fuse holder.
- Check the 12v supply to the boiler, it should be above 12v.
- Check the 12v cable is plugged into the boiler. Check the cable is plugged into the Alde control panel.

The boiler will not ignite on gas

- Check the gas cylinder is full. Try a different gas cylinder ensuring it is propane gas.
- The system may not need to use gas heating if also using electric heating.
- The fluids in the boiler may already be at operating temperature.

The boiler will not heat on 230v electric

- Check that any 230v isolator switches are on (they will often have an LED indicator).
- Check the 230v supply to the vehicle.
- The fluids in the boiler may already be at operating temperature.

No hot water

- Check that "hot water ignore" is not activated on the Alde control panel.
- Check that constant pumping is not activated on the Alde control panel.
- Check for other conflicting settings on the Alde control panel.
- Check the freshwater supply and water pump.

No central heating

- Bleed the system of air.
- Check the fluid level in the expansion tank.
- Check that the circulation pump is responding.
- Check that "hot water boost" is not activated on the Alde control panel.
- Use gas and electric heating.
- Check that vents in the furniture are not obstructed.
- Check the condition of the heat transfer fluid.

Most vehicles will reach a comfortable temperature within an hour, in non-extreme conditions.

If problems persist, please contact Alde, or your dealer or installer.

WARRANTY

Alde undertakes to rectify any manufacturing defect or early component failure through normal use that occurs within 12 months of the installation date.

If your Alde boiler develops a fault, your first action should be to contact your dealer or installer, as they will be familiar with your installation and vehicle, and how to make a claim under warranty.

Alde International (UK) Ltd
Huxley Close
Park Farm South
Wellingborough
Northamptonshire
NN8 6AB

Tel. +44 (0) 1933 677765

www.alde.co.uk

ALDE CONTROL PANEL

QUICK START GUIDE

This quick start guide allows end users to confidently use the core features of their Alde control panel. See the operating and installation instructions for the Alde control panel for more details.

STARTING THE SYSTEM



Both the control panel and boiler are off.

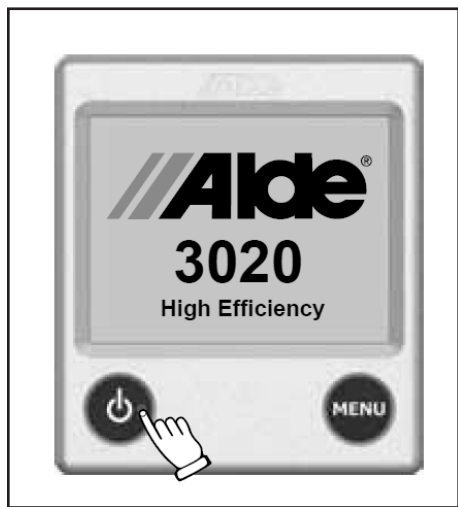

To start the system, press the Power button on the control panel.

STANDBY SCREEN

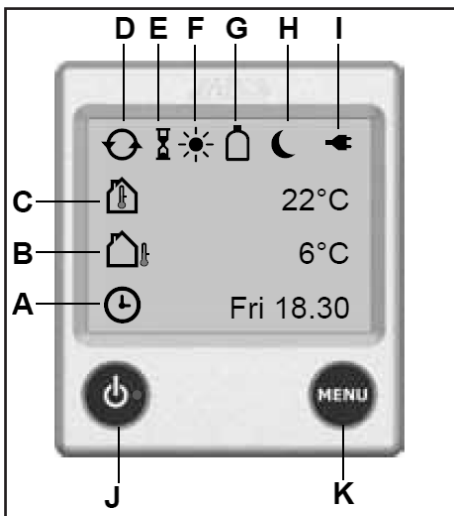

The Standby Screen is displayed after the Splash Screen. This screen contains useful information about the status of your heating system.

NB: If Standby Screen is set to "Dark" in Backlight settings the Standby Screen will not be displayed. The screen will stay dark unless touched.

- A. Clock is enabled.
Day of the week and time shown.
- B. Outdoor temperature
Optional outdoor temperature sensor required.
- C. Room temperature
Measured at the control panel.
[Optional discrete room temperature sensors available.]
- D. Central heating circulation pump is active.
- E. Delayed Start/Cycle is enabled.
- F. Day Mode active.
- G. Gas Cylinder Status
Full/empty and active EisEx shown.
[Additional accessories required.]
- H. Night Mode active.
- I. 230 V supply.
- J. Power button.
- K. Menu button.

MAIN MENU

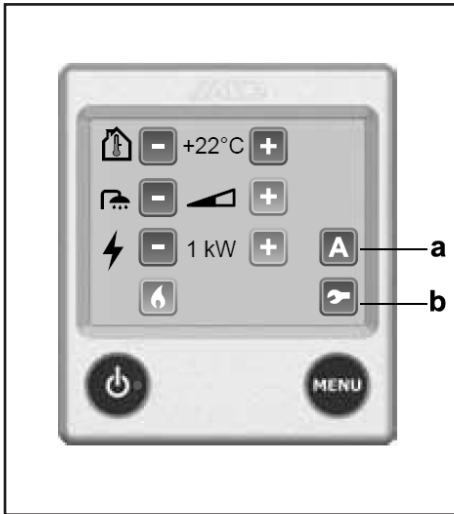

To access the main menu at any time press the menu button.

- a. What's Activated Menu (not displayed if no activated functions are detected).
- b. Settings Menu.

DESIRED ROOM TEMPERATURE

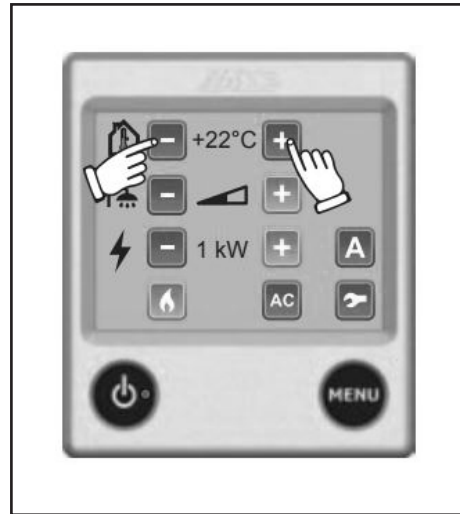

The desired room temperature can be set from 5°C to 30°C, in 0.5°C increments.

1. The current desired room temperature is displayed.
2. Adjust by pressing plus or minus button.



If Day or Night Mode are active the temperature cannot be adjusted. The plus and minus buttons will be greyed out.



The World Health Organisation recommends a room temperature of 18-24°C for healthy living.

HOT WATER IGNORE

Volume bar empty. No attempt is made to heat hot water specifically. This saves energy when the freshwater is drained down.

HOT WATER NORMAL

Volume bar half full. Hot water is heated to greater than 50°C. NB: If circulation pump is set to Continuous, this option will not be available.

HOT WATER BOOST

Volume bar full. Central heating circulation is disabled for 30 mins. Hot water is heated to greater than 65°C. After 30 mins the system reverts to Hot Water Normal. Adjust by pressing plus or minus button.

The Alde boiler stores 8.4 litres of hot water as standard. If the hot water cylinder is empty, the air is heated but no damage can result.



If Day or Night Mode's Hot Water Ignore is active the hot water cannot be adjusted. The plus and minus buttons will be greyed out.

ELECTRIC HEATING



Check that 230v supply is displayed on the Standby Screen. The Alde boiler is programmed to use power economically and there are times when it may use no power at all, even if set to 3kW.

- Select Off, 1, 2 or 3kW electric heating. More power equals better performance, but may be restricted by the current (amps) limit on the electric hook-up.
- Adjust by pressing plus or minus button.

Max current draw from 230v supply is 4.5A on 1kW, 9A on 2kW, 14A on 3kW. If the electric supply has unstable voltage, the amperage will also fluctuate.

GAS HEATING



The Alde boiler is programmed to use power economically. The gas burner has two stages, shifting dynamically between low or full flame. There are times when it may use no power at all, even if gas heating is selected.

- Press the Flame button to select gas heating. Green is on, blue is off.

Use both gas and electric heating for best performance.

SHUTTING DOWN THE SYSTEM

To save energy, the control panel only updates the boiler after the last adjustment is made. Wait 10 secs before shutting down the system to ensure the boiler is updated. Press the Power button again. The screen goes dark, the green LED is unlit. The system is off.

SETUP

Most UK installations do not need setting up in the Settings Menu, and use default factory settings.

RESTORE DEFAULT FACTORY SETTINGS

Before using the system for the first time, restore default factory settings. Your control panel may have been tested by the dealer or installer, and some settings may have been changed.

Press Tool button to access the Settings Menu (bottom right in Main Menu).

Press down arrow, until Reset button is displayed.

Press the Reset button to proceed.

SETUP EXPANSION TANK PUMP

To use the 12v circulation pump in the expansion tank, you must set it up. This is not a default factory setting.

NB: Under factory settings, the system will use the 12v inline circulation pump by default.

Press Tool button to access the Settings Menu (bottom right in Main Menu).

Press down arrow, until Circulation Pump button is displayed.

Press Circulation Pump button, select Expansion Tank Pump to proceed.

SET UP ANTIMICROBIAL FUNCTION

To actively kill Legionella, set up the Antimicrobial function. At 2:00 every night, the hot water will be heated to over 65°C for 30 mins. This further reduces the risk of Legionella.

Press Tool button to access the Settings Menu (bottom right in Main Menu).

Press down arrow, until Antimicrobial button is displayed.

Press Antimicrobial button to proceed.

SETUP STANDBY SCREEN FOR BEDTIME

The backlight on the Standby Screen can be disturbing if the control panel is visible from your bed. It can be inverted for white text on

black background.

Press Tool button to access the Settings Menu (bottom right in Main Menu).

Press down arrow, until Backlight button is displayed.

Press Backlight button, select Inverted to proceed.

MAINTENANCE

The Alde control panel requires no maintenance, other than cleaning of the screen as needed. Use a microfibre cloth to clean the touchscreen.

NB: Consider removing the Alde control panel over winter, if the vehicle is to be kept in storage and is susceptible to damp.

TROUBLESHOOTING

Any error messages will be displayed on the Standby Screen. Error messages can be cleared by switching off 12v supply to the boiler for 10 secs.

The system is completely dead/the control panel is blank.

Check the 20mm T3.15Amp glass fuse in the boiler. This is located under the lid of the black plastic service hatch, in a green plastic fuse holder.

Check the 12v supply to the boiler, it should be above 12v.

Check the 12v cable is plugged into the boiler.

Check the cable is plugged into the Alde control panel.

Panel failure 1 & and Panel failure 2

Moisture is trapped in the control panel.

Remove the Alde control panel from the vehicle and air in a warm, dry place overnight.

“Gas failure”

Out of gas or gas is not igniting.

Check the gas cylinder is full. Try a different gas cylinder, ensuring it is propane gas.

Overheat red fail or Overheat blue fail

Bleed the system of air.

Check the fluid level in the expansion tank. It should be 1cm above min mark when cool.

Check the circulation pump is responding.

Wait 15 mins for the fluid to cool down.

Overheat PCB

Failsafe in boiler has triggered.
Check the fluid level in the expansion tank. It should be 1 cm above the Min mark when cool.
Check the boiler compartment is ventilated, and that the vents are unobstructed. Do not place stowage in the boiler compartment.

Fan failure

Combustion fan speed too low. Bearing may be stiff after a period of disuse.
Automatically clears after 5 mins. Please try again.

Connection failure

Loose connection between Alde control panel and boiler.
Unplug cable at the control panel and boiler, then carefully plug back in.
Check there is slack on the cable at the control panel, but not excessive weight from free-hanging/unmanaged cable.

Window open

Optional window sensor has triggered, gas heating is suspended. Automatically clears and gas heating resumes when window is closed.

Connection fail ext

Break in communications between Alde control panel and daisy-chained third party control panel.
Check the cable between the Alde control panel and third party control panel.

Low battery

12v supply to boiler has dropped below 10.5v, possibly causing system brownout.
Automatically clears when 12v supply reaches 11v.

No match Heater/Panel

Control panel is incompatible with boiler PCB.
Check control panel part number. Control panel 3020-013 is for 3020 A-series boiler, 3020-113 is for 3020 HE-series boiler.

If problems persist, please contact Alde, or your dealer or installer.
For frequently asked questions, or download all instruction manuals, please visit Alde's web site at:
www.alde.co.uk

BATTERY BACK UP

Certain Bailey models feature battery back up. This feature means that when all power to the caravan is cut or fails the Alde control panel will maintain its memory and settings.



The back up hardware comprises of a lead and a battery holder which accepts x2 AA batteries.

Upon receipt of your caravan you will need to insert x2 AA batteries.

The back up module is located behind the cutlery drawer.

TRUMA COMBI E

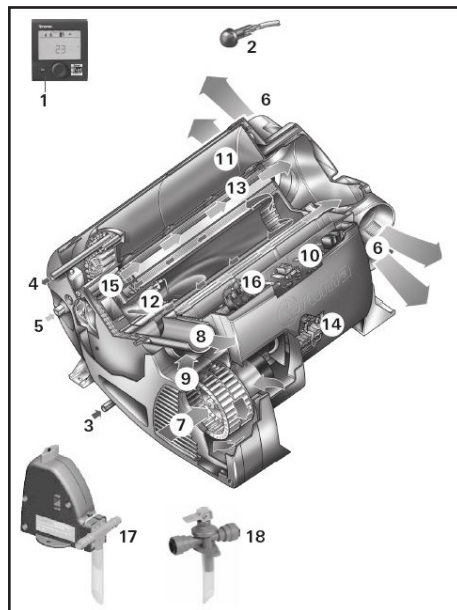

1. Control Panel
2. Room Temperature Sensor
3. Cold Water Connection
4. Hot Water Connection
5. Gas Connection
6. Hot Air Outlets
7. Recirculated Air Intake
8. Waste Gas Discharge
9. Combustion Air feed
10. Electronic Control Unit
11. Water Container (10 litres)
12. Burner
13. Heat Exchanger
14. Power Electronics
15. Heating Elements 230V
16. Overheating Switch 230V
17. Frost control (Optional)
18. Safety Drain Valve

FUNCTION DESCRIPTION

The liquid gas heater Combi E is a warm-air heater with integrated hot water boiler (10 litres volume). The burner is fan assisted, which ensures that operation is problem-free, even when on the move. The unit also has heating elements for electrical operation. In heating and hot water mode the heater can be used to heat the room and heat water up at the same time. If only hot water is required, select hot water mode. At a temperature of approximately 3 °C at the automatic FrostControl safety/drain valve, the valve will open and drain the boiler.

3 different options are available for operating the unit:

- Gas mode only Propane / Butane for autonomous use.
- Electrical mode only 230 V for stationary use on camp sites
- Gas and Electrical mode - mixed mode only possible in winter.



Mixed operation is not possible. With this setting the unit automatically selects electrical operation. The gas burner is not enabled.



Repairs may only be carried out by an expert.

HEATING AND HOT WATER MODE

In heating and hot water mode, the unit automatically selects the required operating level according to the temperature difference between the temperature set on the control panel and the current room temperature. If the boiler has been filled, the water is automatically heated as well. The water temperature depends on the selected operating mode and the heater output.

All 3 energy selection options can be used for winter deployment.

- In gas mode the unit automatically selects the operating level that is required.
- In electrical mode output of 900 W (3.9 A) or 1800 W (7.8 A) can be manually preselected in accordance with the fuse protection at the camp site.

If more output is required (e.g. heating up or low outside temperatures) gas or mixed mode

should be selected so that enough heating power is always available.

- In mixed mode 230 V electrical mode is preferred if the power requirement is low (e.g. for maintaining the room temperature). The gas burner is not enabled until the power requirement is higher, and is the first to switch off during heat-up operations.

HOT WATER MODE (WITH FILLED BOILER ONLY)

Gas mode or 230 V electrical mode is used to generate hot water. The water temperature can be set to 40 °C or 60 °C.

- In gas mode the water is heated at the lowest burner setting. Once the water temperature has been reached, the burner switches off.
- In electrical mode output of 900 W (3.9 A) or 1800 W (7.8 A) can be manually selected in accordance with the fuse protection at the camp site. Mixed mode is not possible. With this setting the unit automatically selects electrical mode. The gas burner is not enabled.

OPERATING INSTRUCTIONS

Read the safety instructions and operating instructions carefully before starting the unit.

The installer or vehicle owner must apply the yellow sticker with warning information, which is enclosed with the appliance, to a place in the vehicle where it is clearly visible to all users (e.g. on the wardrobe door) Ask Truma to send you stickers if necessary.

Before using for the first time it is essential to flush the entire water supply system through with clean water.

If the heater is not being used, always drain the water contents if there is a risk of frost. There shall be no claims under guarantee for damage caused by frost.

Materials in the device which come into contact with water are suitable for use with drinking water (see manufacturer declaration: www.truma.com - Manufacturer Declaration).

ROOM THERMOSTAT

To measure the room temperature, an external room temperature sensor (s) is located within the vehicle by the control panel.



The thermostat setting on the control panel (1-5) must be determined individually depending on the heating requirement and the type of vehicle. For an average room temperature of about 23 degrees we recommend a thermostat setting of about 4.

FILLING THE WATER HEATER

- Check the safety/drain valve within the cold water intake is closed. The lever should be in horizontal position e.

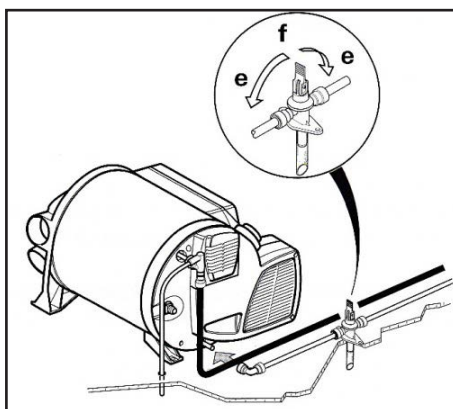

- e. Lever position "closed"
- f. Lever position "drain"

- Open the hot tap in the bathroom or kitchen, with pre-selecting mixing taps or single-lever fittings set to "hot".
- Switch on power for water pump (main switch or pump switch).
- Leave tap open to let air escape while the water heater is filling. The heater is filled when water flows out of the tap.

Residue of frozen water can prevent filling if there is a frost. The water heater can be defrosted by switching on the heater for a short period. Frozen pipes can be defrosted by heating the room.

DRAINING THE WATER HEATER



If the caravan is not used during the winter the boiler must be drained prior to storage

- Disconnect power for water pump.
- Open hot the water tap in the bathroom and kitchen.
- Open safety/drain valve: Move the lever to vertical position f.

The water heater is now drained directly to the outside via the safety/drain valve. Check that the water contents have been completely drained (10 litres).

FILLING THE WATER HEATER (AFTER MARKET FROST CONTROL VALVE)

- Check if the rotary switch for the drain valve is set to "Operation" parallel to the water connection and engaged.
- Close the drain valve by pushing the button until it engages.
- When the temperature at Frost control is below about 7°C, first switch on the heater to warm the installation compartment and Frost control. After several minutes, when the temperature at Frost control is above 7°C the drain valve can be closed.
- Switch on power for water pump (main or pump switch).
- Open hot water taps in kitchen and bathroom, (set preselecting mixing taps or single-lever fittings to "hot").
- Leave the fittings open for as long as it takes for the boiler to displace the air and fill up and the water to flow without interruption.

If just the cold water system is being operated without using the water heater, the heater tank also fills up with water. To avoid frost damage the boiler must be drained through the drain valve even if it was not operated.

When connecting to a central water supply (rural or city mains) a pressure reduction valve must always be installed to prevent above 2.8 bar from developing in the water heater.

DRAINING THE WATER HEATER (AFTER MARKET FROST CONTROL VALVE)

- Switch off power to water pump (main or pump switch).
- Open hot water taps in kitchen and bathroom.
- In order to check the water that is flowing out, place an appropriate container

(capacity 10 litres) beneath the drain valve (Frost control) drainage muff.

- Turn the rotary switch on the drain valve by 180° until it engages, whereby the push button moves out and the drain valve opens.



Check whether all of the water in the boiler (10 litres) has been drained into the container via the drain valve.

There shall be no claims under guarantee for damage caused by frost.

START UP

Heating is possible with gas, electrical and mixed operation. Also with or without water.



Check to make sure the flue is unobstructed. Be sure to remove any covers that may be present.

- Turn on gas cylinder and open quick-acting valve in the gas supply line.
- Check whether the power supply fuse protection on the camp site is adequate for the 900W (3.9A) or 1800W (7.8A) that has been selected using the power selector switch.
- Fill boiler with water if necessary.
- Switch on the unit on the control panel.

SWITCHING OFF

- Switch the heater off on the control panel.
- The switch-off procedure may be delayed by several minutes because of internal heater operations.



Always drain water contents if there is a risk of frost

If the appliance is not used for a long period, close the quick acting valve in the gas supply line and the gas cylinder.

MAINTENANCE

Only original Truma parts may be used for maintenance and repair work.

- Clean the compartment where the unit is installed at least once annually.
- Have an expert check the unit for dirt and clean it if necessary.
- The safety/drain valve must be operated regularly (at least twice annually) to

remove limescale deposits and to be certain that it is not blocked.

We recommend the use of suitable commercially available products to clean, sterilise and maintain the boiler. Products containing chlorine are not suitable.

The effectiveness of the use of chemicals to combat micro-organisms in the appliance can be increased by heating the water in the boiler to 70 °C at regular intervals.

- Select "Gas mode".
- Set the water temperature to 60 °C.
- Switch on the appliance.



Once the water in the boiler has reached a temperature of 60 °C, the burner will switch off. The appliance must stay switched on for at least 30 minutes and no hot water may be removed. The residual heat in the heat exchanger will heat the water up to 70 °C.

12v FUSE REPLACEMENT

The fuse is in the electronics beneath the connection cover.

Replace the unit's fuse only with an identical fuse.

Device fuse 10 A - low - (T 10 A)

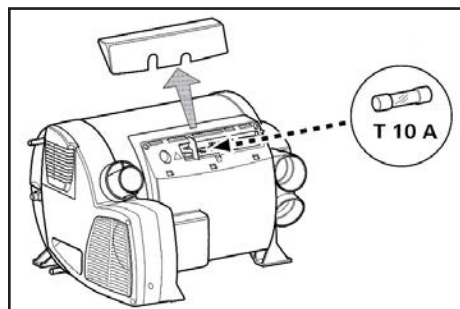

OVERHEATING PROTECTION 230v

The 230v heating facility has a mechanical overheating switch. If the 12v power supply is interrupted during operation or during the after-run period for example, the temperature within the unit could activate the overheating protection.

To reset the overheating protection, allow heater to cool, remove connection cover and press red reset button.

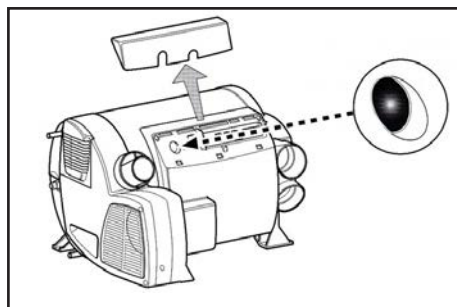

230v FUSE REPLACEMENT

The fuse and the power supply lines must only be replaced by an expert.

The unit must be disconnected from the mains before opening the electronic housing lid.

The fuse is in the power electronics beneath the electronic housing lid.

This fine fuse must always be replaced with a fuse of the same type: T 10 A slow, interrupting capacity H.

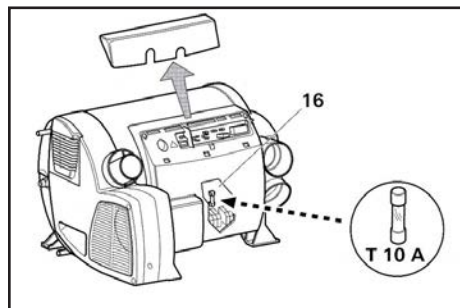

TRUMA DIGITAL CONTROL PANEL

SAFETY INSTRUCTIONS

- The device may only be operated if it is in perfect working order.
- Arrange for malfunctions to be rectified immediately.
- Do not repair or modify the device.
- Only allow the manufacturer or its customer service to repair a faulty device.



If the power supply to the system is interrupted for longer than 20 minutes, the time and date need to be entered again.

If the Truma Combi heater is connected to the control panel Truma CP Plus, the heater can no longer be switched via a ZUCB timer.

DISPLAY AND CONTROL ELEMENTS

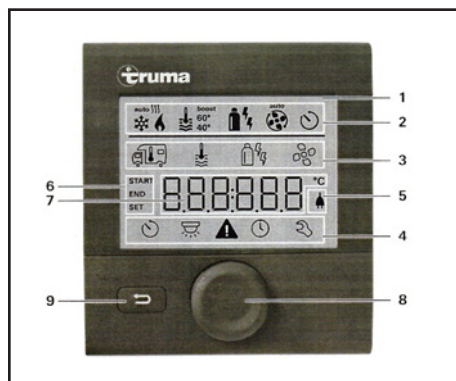

1. Display
2. Status bar
3. Menu line (Upper)
4. Menu line (Lower)
5. Display of mains voltage 230v (Power)
6. Time switch display
7. Settings/values
8. Rotary push button
9. Back button

The menus can be selected in lines (3 + 4) and settings can be made using the rotary push button (8). The display (1) has an illuminated background. The Back button (9) can be used to return from a menu.

ROTARY PUSH BUTTON

Set points and parameters can be selected, modified and saved by tapping on it using the rotary push button (8). Selected menu items flash.

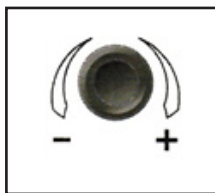

Turn to the right (+)
Menu is paged from left to right. Increase values.
Turn to the left (-)
Menu is paged from right to left. Reduce values.



Clicking Accept (save) a selected value.
Select a menu item or a change to the setting level.

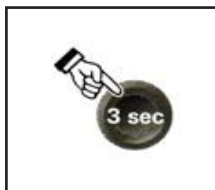

Press (3 seconds) Main switch function ON/OFF

BACK BUTTON

Pressing the Back button (9) returns you from a menu and discards settings. This means that the previous values are retained.

SHUT DOWN PROCEDURE

Truma heating systems now require a correct procedure be followed when shutting down.

1. Press and hold the rotary push button for 3 seconds. The control panel will power down.
2. Power down the van at the master switch control panel.

This process must be followed. Failure to do so will lead error code E-514-H.

In the event of E-514-H being displayed keep the power on and wait till the code stops flashing (Approx. 15 minutes). Then press the rotary button twice to continue as normal.

START UP

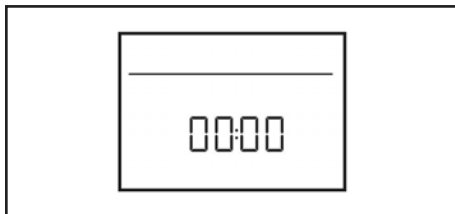

Once connected to the power supply the control panel will display a start screen. This is shown after a few seconds.

If no entry is made within a few minutes, the standby screen is automatically shown again. The display shows the time and correct room temperature alternately.

FUNCTIONS

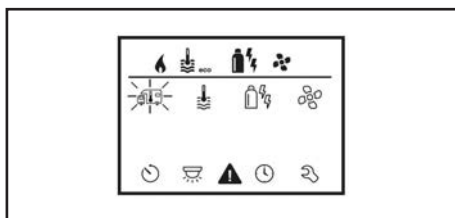

The functions in the menu lines of the control panel can be selected in any sequence. The operating parameters are shown in the status line at the top of the screen above the black line.

The display shows the setting level. The first symbol flashes.



Previously set values/operating parameters become active again after the system is switched on.

Switch on/return to setting level

- Press the control knob/push button for longer than 3 seconds or the back button.

Switch off

- Press the control knob/push button for longer than 3 seconds.

CHANGE THE ROOM TEMPERATURE

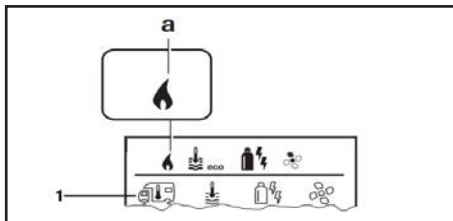

1. Use the control knob/push button to select the vehicle icon.
2. Push knob/push button to access setting level.
3. Use the control knob/push button to select the desired temperature.
4. Click the control knob/push button to confirm the value.

Temperature range 5°C-30°C (1°C steps)

a = Heater status - When visible heater is switched on.

This symbol will flash until the required room temperature is reached.

CHANGE THE HOT WATER LEVEL

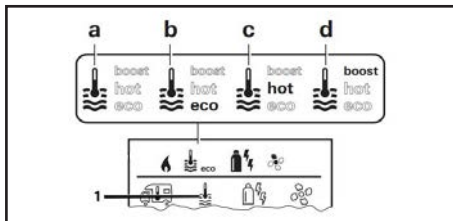

1. Use the control knob/push button to select thermometer icon.
2. Click to change to the setting level.
3. Use the control knob/push button to select the required level.
4. Click the control knob/push button to confirm the value.

a = Boiler - Warm water boiler is switched on.

b = 40° - Warm water temperature 40°C.

c = 60°C - Warm water temperature 60°C.

d = Boost - Targeted, fast heating of the content of the boiler. The water temperature is kept at the higher level (around 62°C).

Once the water temperature is reached, the room is heated again.

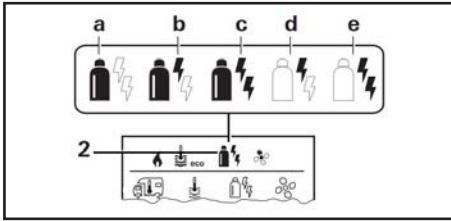
SELECT ENERGY SOURCE

1. Use the control knob/push button to select the energy icon.
2. Click to change to the setting level.
3. Use the control knob/push button to select the required power type.
4. Click the control knob/push button to confirm the value.

SYMBOL	OPERATING MODE	POWER TYPE
a	LP gas	LP gas
b	MIX 1 * Electricity	850W + Gas
c	MIX 2 * Electricity	1700W+ Gas
d	EL 1 * Electricity	850W
e	EL 2 * Electricity	1700W

* Mixed mode

SPECIAL ASPECTS IN THE MIXED MODE

Interruption of the power supply 230v
 Combi Gas: The heater automatically switches to the gas mode. As soon as the 230v power supply is connected, the heater automatically switches back to the mixed mode.

MALFUNCTION IN THE COMBUSTION PROCESS (E.G. LACK OF FUEL)

Combi Gas: The heater automatically switches to the electro mode. If the heater should operate in the mixed mode again, the cause of the malfunction needs to be rectified. Switch the heater off and on again on the control panel.

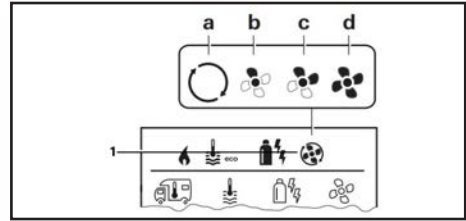
SELECT FAN LEVEL

1. Use the control knob/push button to select the fan icon.
2. Click to change to the setting level.
3. Use the control knob/push button to select the required fan level.
4. Click the control knob/push button to confirm the value.

SET THE TIME SWITCH

1. Use the control knob/push button to select the timer symbol in the bottom corner.
2. Click to change to the setting level.

If the timer is activated (ON), the timer in the menu is shown as deactivated (OFF).

Enter start time

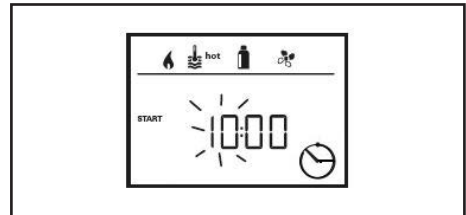

3. Use the control knob/push button to set the hours, then the minutes.

Enter end time point

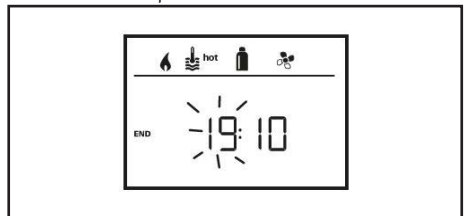

4. Use the control knob/push button to set the hours, then the minutes.
5. If the start time has passed when entered the operating parameters are only taken into consideration when the next start/end times are reached.

Set the Room Temperature

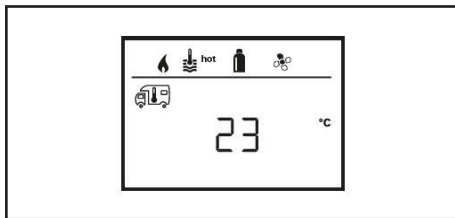

6. Click to change to the setting level.
7. Use the control knob/push button to select the required room temperature.
8. Click the control knob/push button to confirm the value.

Select Fan Level

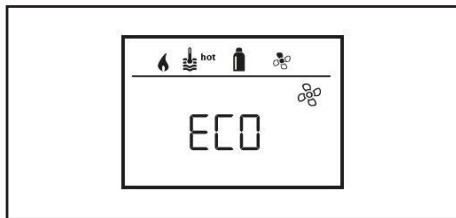

15. Click to change to the setting level.
16. Use the control knob/push button to select the required fan level.
17. Click the control knob/push button to confirm the value.

Set the Hot Water Level

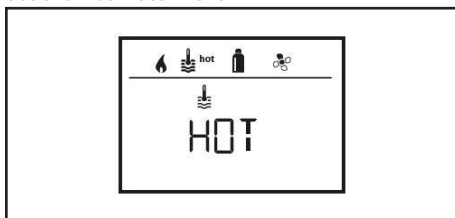

9. Click to change to the setting level.
10. Use the control knob/push button to select the required hot water level.
11. Click the control knob/push button to confirm the value.

ACTIVATE THE TIMER (ON)

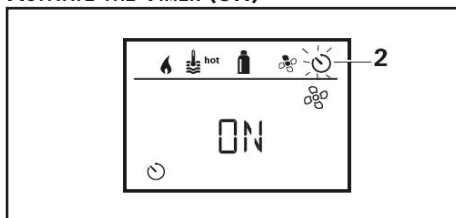

18. Click to change to the setting level.
19. Use the control knob/push button to activate the timer (ON).
20. Click the control knob/push button to confirm the value.

Select Power Type

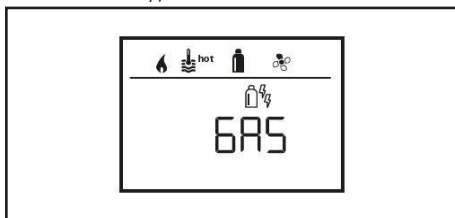

12. Click to change to the setting level.
13. Use the control knob/push button to select the power type.
14. Click the control knob/push button to confirm the value.



The timer remains active, even for several days, until it is deactivated (OFF).

DEACTIVATE THE TIMER (OFF)

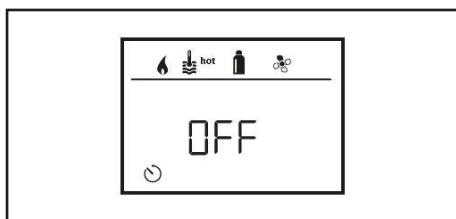

1. Click to change to the setting level.
2. Use the control knob/push button to deactivate the timer (OFF).
3. Click the control knob/push button to confirm the value.

SET TIME

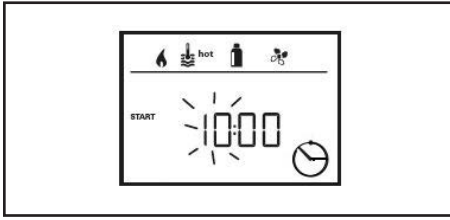

1. Select the clock icon.
2. The hour display flashes.
3. Use the control knob/push button to set the hour (24h mode).
4. After clicking the control knob/push button again, the minute display will flash.
5. Use the control knob/push button to set the minutes.
6. Click the control knob/push button to confirm the value.

DISPLAY MAINS VOLTAGE 230V

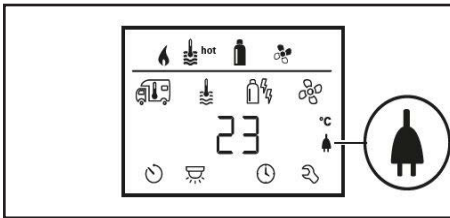

This symbol indicates that 230v mains voltage is available.

WARNINGS

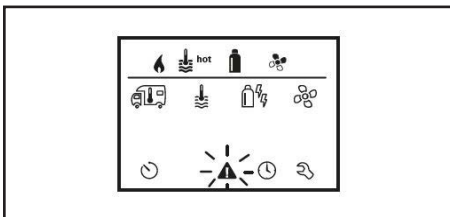

In the event of a warning, a warning symbol appears to indicate that an operating parameter has reached an undefined status. In this case, the affected device continues to run. As soon as the operating parameter returns to set range, this symbol will turn off automatically.

READ OUT OF WARNING

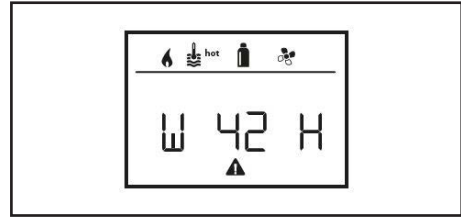

W = Warning
42 = Fault code
H = Device (H=Heater)

1. Use the control knob/push button to select the symbol.
2. Click the control knob/push button. The current warning code is shown. The cause of the warning can be identified and rectified via the error list.

CAUSE RECTIFIED/RETURN TO SETTING LEVEL

- Click the control knob/push button.

CAUSE NOT RECTIFIED/RETURN TO SETTING LEVEL

- Press the back button.



In this case, the warning is not acknowledged on the control panel and the warning symbol remains. The control panel remains in the warning status. Devices connected to the control panel can be operated.

CANCELLING THE WARNING TRIANGLE

When the warning triangle is illuminated it indicates a fault. In order to remove the fault triangle you must first resolve the issue. Once the issue has been resolved rotate the knob until the warning triangle flashes. Depress the knob and the flashing will stop.



If the fault has not been resolved the warning triangle will reappear. Continuous cancelling of the warning triangle when the fault has not been resolved will lock the system. Stopping any further function for up to 15 minutes.

EXTERIOR FEATURES

GRP

GRP components need to be washed, waxed and cared for like a car. Chemicals and dirt can collect during storage, and the outer surface called a gel coat can be stained or marked when chemicals combine with rain or dew. Most stains or marks can be removed with mild dish-washing detergent, but more stubborn marks may require a rubbing compound. To help keep your GRP components looking almost like new, it is wise to wash the parts monthly (or more frequently) using mild dish-washing detergent, but avoid using strong alkaline (e.g. tri-sodium phosphate) or acidic cleaners or abrasives. Waxing the components once or twice a year with a good grade paste wax will help to maintain the colour and finish.

ROOFLIGHTS

HEKI ROOFLIGHTS:

OPENING IN THE TILT SETTING

1. Press the locking buttons at both catches on the glass and turn inwards through approx. 90°.
2. Grasp the bar in the middle, unclasp from the anchoring fasteners, swivel the bar down and push the glass dome upwards. (Glass dome is assisted after approx. 150mm by the two pneumatic springs.)
3. Swivel the bar towards the glass dome and clip into position.
4. To close the HEKI, perform steps (1-3) in reverse order.

OPENING IN THE INTERMEDIATE SETTING

1. Open both catches on the glass.
2. Grasp the bar in the middle, unclasp from the anchoring fasteners, swivel down and push the glass dome upwards. (Glass dome opens automatically after approx. 150mm through the two pneumatic springs.)
3. Open both fasteners, and swivel the bar towards the intermediate setting and pull the glass dome down until the bar rests in the hold.
4. Secure the bar with the two fasteners.
5. To close HEKI, perform steps (1-4) in reverse order.

OPENING IN PERMANENT VENTILATION SETTING

1. Open both catches on the glass.
2. Push glass dome up approx. 2cm with both hands on the two catches and turn the catches to fix them in the ventilation setting.
3. To close HEKI, perform steps (a-b) in reverse order.

CLOSING THE BLIND

1. To close the blind, grasp the end rod (without grip) in the recess and engage in the opposite end rod (with grip).
2. You can move both joined end rods to adjust the blind to the required position (black out/fly screen/sun shade).

OPENING THE BLIND

1. Move the blind right out to the side (end rod with grip).
2. Holding the recess with one hand, press the rocker with the other hand and guide the blind back into position.

SAFETY INSTRUCTIONS

- Do not stand on the acrylic glass.
- Close HEKI completely before moving the vehicle.
- Close HEKI when leaving the vehicle.
- Please consult your dealer when any defects or problems occur.
- Remove snow/ice or other dirt from the roof before opening HEKI.
- Do not open in strong winds or heavy rain.

CARE INSTRUCTIONS

- Please clean the acrylic panes with the Seitz Acrylic Cleaner.
- Stains and light scratches on the acrylic pane can be removed using the Seitz Acrylic Polish and Seitz special polishing cloth.
- Only use water and mild soap suds to clean the blinds.
- Failure to comply with these instructions will make the warranty null and void.

MPK ROOFLIGHT

The MPK rooflight is situated in the bathroom of your caravan over the shower compartment. It is fitted with a fly screen for your comfort. The fly screen is hinged, allowing you access to the handles that enable you to raise the rooflight's dome for ventilation.

To raise the dome pinch the black parts of the handle against the other half on both sides and push upwards. Both sides can be raised or just one, depending on your preference.

COOKING EQUIPMENT



Never use oversized pans as this will lead to damage within the caravan.

- Each burner will support pans from $\varnothing 10$ to $\varnothing 20$ cm; care should be taken not to overload the appliance as performance may be reduced.
- The following pan sizes are the maximum we recommend:
- Electric hotplate: - $\varnothing 180$ mm (Dual Fuel only)
- Auxiliary burner: $\varnothing 200$ mm
- Semi-rapid burner: 2x $\varnothing 200$ mm or 1x $\varnothing 200$ mm with 1x $\varnothing 180$ mm
- When using small pans the flames should not spread beyond the base of the pan as this will reduce the efficiency of the burner.
- Avoid old or misshapen pans as these may cause instability.
- The lid must be opened fully prior to using the hotplate burners.
- For guaranteed damage free cooking it is recommended you use $\varnothing 180$ mm pans.

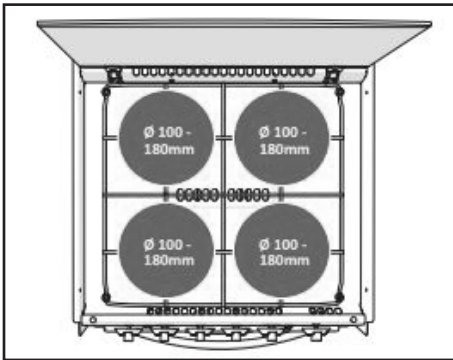

Never use the cooker as a space heater

Before using the appliance please ensure that you are aware of the following:

- Appliance and accessible parts become hot during use.
- Avoid touching heating elements.
- Children less than 8 years of age shall be kept away unless continuously supervised.

This appliance can be used by children aged 8 years and above, persons with reduced physical, sensory or mental capabilities and/or lack of experience and knowledge only if they

have been given supervision or instruction concerning use of the appliance in a safe way and understand the hazards involved.

- Children shall not play with the appliance.
- Cleaning and user maintenance shall not be made by children without supervision.
- Unattended cooking on a hob with fat or oil can be dangerous and may result in fire.
- Never extinguish a fire with water; switch off the appliance and cover flame with lid or fire blanket.
- Danger of fire: Do not store items on the cooking surface.
- Do not use harsh abrasive cleaners or sharp metal scrapers to clean the oven door glass since they can scratch the surface, which may result in shattering of the glass.
- Never use a steam cleaner to clean the appliance.

OPERATION

The burners on this appliance have fixed aeration and no adjustment is required. The burners should flame as follows:

Propane: The flames should burn quietly with a blue/green colour with no sign of yellow tips.
Butane: Normally, on initial lighting, a small amount of yellow tipping will occur. This then increases slightly as the burner heats up.

USING THE HOTPLATE GAS BURNERS



Ensure that the glass lid is open before turning on the burners.

- Glass lids may shatter when heated.
- Turn off all burners before shutting the lid.
- The glass lid has a tendency to snap shut towards the lowered position. Ensure fingers are away from the entrapment area when closing the lid.
- Remove all spillages from the glass lid before opening.
- Children should be supervised to ensure that they do not play with the appliance.
- Ensure gas cylinder/supply is connected and turned on. In the event of a gas smell turn off at gas cylinder/mains and contact supplier.
- Flame supervision: each burner is controlled individually and is monitored by a thermocouple probe. In the event of the burner flames being accidentally

extinguished, turn off the burner control and do not attempt to re-ignite the burner for at least one minute.

LIGHTING PROCEDURE

1. Push in the control knob and turn to full rate-large flame.
 2. Hold in knob and light the hob by depressing the ignition button, which is located on the fascia. It is necessary to hold the knob depressed after the burner has ignited for approximately 10-15 seconds, to allow the thermocouple probe to reach temperature, before releasing the knob.
- Should the flame go out when the knob is released, the procedure should be repeated holding the knob depressed for slightly longer.
 - If the burner has not lit within 15 seconds the control knob should be released and the burner left for at least 1 minute before a further attempt to ignite the burner.
 - For simmering, turn the knob further anti-clockwise to the low rate position.
 - To turn off: turn the control knob until the line on the control knob is aligned with the zero on the control panel. Always make sure the control knob is in the off position when you have finished using the hotplate burners.

USING THE ELECTRIC HOTPLATE (DUAL FUEL MODELS)

1. Ensure power is switched on.
2. The hotplate control is numbered from 1 to 6. To turn it on, rotate the knob either clockwise or anti-clockwise to the required position. Position 1 is the coolest setting.
3. To turn off, rotate the knob until the line or pointer on the knob lines up with the zero on the control panel.

The hotplate is a sealed construction and transfers heat through conduction. For maximum efficiency a correctly sized pan with a flat heavy gauge base should be used. Pan size should be the same or slightly larger (up to 1" / 2.5cm oversize).

Before using your hotplate for the first time, we recommend that you prime it.

TO PRIME THE HOTPLATE

1. Switch on the hotplate for a short period, without a pan, to harden and burn off the coating.
2. Use a medium to high setting for 3-5 minutes. A non-toxic smoke may occur during this process.
3. Allow it to cool.

USING THE GRILL

Ensure gas cylinder/supply is connected and turned on. In the event of a gas smell turn off at gas cylinder/mains and contact supplier.

TO LIGHT

1. Open door.
2. Push in the control knob and turn to full rate/large flame.
3. Push the control knob in and hold whilst pressing the ignition switch.
4. The burner should ignite and the control knob should be held in for 10-15 seconds before release. If the burner goes out, repeat procedure holding control knob for slightly longer.

On first use of the grill, it should be heated for about 20 minutes to eliminate any residual factory lubricants that might impart unpleasant smells to the food being cooked. A non-toxic smoke may occur when using for the first time so open any windows and turn on mechanical ventilators to help remove the smoke.

Although the grill does heat up quickly, a few minutes preheat is recommended.

Flame Failure Device (FFD): the grill burner is fitted with a flame-sensing probe, which will automatically cut off the gas supply in the event of the flame going out. In the event of the burner flames being accidentally extinguished, turn off the burner control and do not attempt to re-ignite the burner for at least 1 minute.

It is normal for the flames on this burner to develop yellow tips as it heats up.

A reversible grill pan trivet enables the correct grilling height to be achieved.

TO TURN OFF

1. Turn the control knob until the line on the control knob is aligned with the dot on the control panel. Always make sure the control knob is in the off position when you have finished grilling.



The grill area can get hot when the oven is in use, even if the grill is switched off. Care should be taken when removing pans from the grill, i.e. by use of oven gloves, and by making use of the removable grill pan handle.



The grill pan supplied is multi-functional, for use in grill or oven. The handle design allows removal or insertion while the pan is in use. Always remove the handle when the pan is in use. The grill **MUST** only be used with the door open.

USING THE OVEN

Ensure gas cylinder/supply is connected and turned on. In the event of a gas smell turn off at gas cylinder/mains and contact supplier.

TO LIGHT

1. Open door.
2. Push in the control knob and turn to full rate (240°C).
3. Push the control knob in and hold whilst pressing the ignition switch.
4. The burner should ignite and the control knob should be held in for 10-15 seconds before release. If the burner goes out, repeat procedure holding control knob for slightly longer.
5. Place the oven shelf in the required position and close the door.
6. Set the control knob to required temperature.

Although the oven heats up quickly, it is recommended that a 10 minute preheat be allowed. The oven should be up to full temperature in about 15-20mins.

TO TURN OFF

1. Turn the control knob until the line on the control knob is aligned with the zero on the control panel.

The shelf has been designed to allow good

circulation at the rear of the oven and is also fitted with a raised bar to prevent trays or dishes making contact with the back of the oven. To remove a shelf, pull forward until it stops, raise at the front and remove. Installation of a shelf is the reverse of this procedure.



Before first use, heat the oven for about 30 minutes at 200°C, to eliminate any residual factory lubricants that might impart unpleasant smells to the meals being cooked. A non-toxic smoke may occur when using for the first time so open any to help remove the smoke. Always ensure food is properly cooked prior to serving.

OVEN TEMPERATURE CONTROL

The temperature in the oven is controlled by a thermostatic gas tap and is variable over the range 130°C to 240°C. Approximate temperatures for the settings on the control knob are shown in the table overleaf. The temperatures indicated refer to the centre of the oven and at any particular setting the oven will be hotter at the top and cooler towards the base.

The variation between top and centre, and centre to bottom is approximately equivalent to one gas mark. Good use can be made of the temperature variation in that several dishes requiring different temperatures may be cooked at the same time. In this way maximum benefit can be obtained from the gas used to heat the oven. Care should be taken not to overload the oven, with adequate spacing being used to allow free circulation for heat.

COOKING GUIDELINES

Although the oven heats up quickly, it is recommended a 10 minute preheat be allowed. The oven should reach full temperature in 15-20 minutes.

When roasting with aluminium foil, care must be taken that the foil does not impair circulation or block the oven flue outlet.

GAS MARK	TEMPERATURE (CENTRE OF OVEN)			DISH
1/4 - 1/2	265 - 275°F	130-135°C	Very Cool	Meringues
1	285	140	Cool	Stewed Fruit
2	300	150	Cool	Rich fruit cake, rice pudding
3	330	165	Warm	Baked custard, shortbread fingers
4	355	180	Moderate	Victoria sandwich
5	385	195	Fairly Hot	Whisked sponges, ginger nuts
6	410	210	Hot	Short crust pastry
7	430	220	Hot	Bread, scones, flaky pastry
8	445	230	Very Hot	Puff pastry
9	465	240	Very Hot	Quick browning

DOS AND DON'TS

DO read the user instructions carefully before using the appliance for the first time.

DO allow the oven to heat before using for the first time, in order to expel any smells before the introduction of food.

DO clean the appliance regularly.

DO remove spills as soon as they occur.

DO always use oven gloves when removing food shelves and trays from the oven.

DO check that controls are in the off position when finished.

DO read the user instructions carefully before using the appliance for the first time.

DO NOT allow children near the cooker when in use. Turn pan handles away from the front so that they cannot be caught accidentally.

DO NOT allow fats or oils to build up in the oven trays or base.

DO NOT use abrasive cleaners or powders that will scratch the surface of the appliance.

DO NOT under any circumstances use the oven as a space heater.

DO NOT put heavy objects onto open grill and oven doors.

DO NOT allow the door to fall down: lower it by hand.



Ensure that the ceramic ball mixer tap arm is clear from the oven lid before raising it. Failure to do so could accidentally switch on the tap when lifting the glass lid.

MAINTENANCE AND SERVICING

This appliance needs little maintenance other than cleaning. All parts should be cleaned using warm soapy water. Do not use abrasive cleaners, steel wool or cleansing powders. When cleaning the burner ring it is essential to ensure that the holes do not become blocked. The control knobs are push fit and can be removed for cleaning. They are interchangeable without affecting operation.



All servicing must be carried out by an approved competent person. After every service the appliance must be checked for gas soundness.

LEAKS



If a smell of gas becomes apparent, the supply should be turned off at the cylinder IMMEDIATELY.

- Extinguish naked lights including cigarettes and pipes.
- Do not operate electrical switches.
- Open all doors and windows to disperse any gas escape.
- Never check for leaks with a naked flame; leak investigation should be carried out using a leak detector spray.
- Check the gas is not escaping from an unlighted appliance.

SERVICE

The cooker must be serviced at least once every 12 months. All servicing must be carried out by an approved competent person. Before any service work is started, the appliance should have been left to cool and be disconnected at the mains socket. After each service the appliance must be checked for gas soundness.

For service, please contact your authorised local service agent giving details of the model and serial number on the data badge plus date of purchase.



Various models have both a worktop lid and glass lid covering the hob burners. Please be aware that both the glass and worktop lids may become hot during the use of the grill and/or oven. Therefore Bailey and Thetford strongly advise you lift both lids up when using the grill and/or oven to avoid any potential product/injury issues.

RUSSELL HOBBS MICROWAVE



This appliance can be used by children aged from 8 years and above and persons with reduced physical, sensory or mental capabilities or lack of experience and knowledge if they have been given supervision or instruction concerning use of the appliance in a safe way and understand the hazards involved. Children shall not play with the appliance.

Do not use harsh abrasive cleaners or sharp metal scrapers to clean the oven door glass since they can scratch the surface, which may result in shattering of the glass.

Cleaning and user maintenance shall not be made by children unless they are aged from 8 years and above and supervised.



Do not use the microwave when it is empty. This could damage the oven.



The appliance and its accessible parts become hot during use. Care should be taken to avoid touching heating elements.



If the door or door seals are damaged, the oven must not be operated until it has been repaired by a competent person.



It is hazardous for anyone other than a competent person to carry out any service or repair operation that involves the removal of a cover which gives protection against exposure to microwave energy.



Liquids and other foods must not be heated in sealed containers since they are liable to explode.



Only allow children to use the oven without supervision when adequate instructions have been given so that the child is able to use the oven in a safe way and understands the hazards of improper use.

- If the supply cord is damaged, it must be replaced by the manufacturer, its service agent or similarly qualified persons in order to avoid a hazard. When heating food in plastic or paper containers, keep an eye on the oven due to the possibility of ignition.
- Only use utensils that are suitable for use in microwave ovens.
- You should clean the outside of the oven with a damp cloth. Do not allow water to seep into the ventilation openings.
- Do not allow the control panel to become wet. Clean with a soft, damp cloth. Do not use detergents, abrasives or spray-on cleaners on the control panel.
- If steam builds up inside or around the outside of the oven door, wipe with a soft cloth. This may happen when the microwave oven is used in humid conditions.
- Regularly remove the glass turntable to clean it, and wash it in warm soapy water. Regularly clean the turntable support and oven floor. Simply wipe the bottom surface of the oven with mild detergent and water, then dry. You can wash the turntable support in mild soapy water.
- The rear surface of appliance may be placed against a wall. Leave a minimum clearance of 30cm above the oven, a minimum clearance of 20cm is required between the oven and any adjacent walls.
- The microwave oven should be used free standing only and must not be built-in or used in a cabinet.
- If smoke is emitted, switch off or unplug the appliance and keep the door closed in order to stifle any flames.
- Microwave heating of beverages can result in delayed eruptive boiling, therefore care must be taken when handling the container.
- Eggs in their shell and whole hard-boiled eggs should not be heated in microwave ovens since they may explode, even after microwave heating has ended.
- The oven should be cleaned regularly and any food deposits removed. Failure to maintain the oven in a clean condition could lead to deterioration of the surface that could adversely affect the life of the appliance and possibly result in a hazardous situation.
- Before you clean the oven, turn it off and

unplug it. Keep the inside of the oven clean. When food or liquids stick to the oven walls, wipe with a damp cloth. We recommend that you do not use harsh detergent or abrasives.

- The contents of feeding bottles and baby food jars shall be stirred or shaken and the temperature checked before consumption in order to avoid burns.
- Food containing a mixture of fat and water (for example, stock) should stand for 30 to 60 seconds in the oven after it has been turned off. This is to allow the mixture to settle and to prevent it from bubbling when a spoon is placed in it, or a stock cube is added.
- When heating or cooking food or liquid, remember that there are certain foods (such as, jam, Christmas puddings and mincemeat) which heat up very quickly.
- When heating or cooking foods that contain a lot of fat or sugar, do not use plastic containers.
- Always have the glass tray and turntable support in place when using the oven.
- Never remove parts from the oven such as the feet, screws and so on.
- Do not cook food directly on the glass tray. Put food on a suitable plate or in a bowl before putting it in the oven. To reduce the risk of fire in the oven cavity:
- Do not overcook food.
- Do not leave the microwave oven unattended while you are using it and if using paper or plastic containers check regularly to ensure they do not ignite.
- Remove wire twist-ties from bags before putting the bag in the oven.
- If materials inside the oven smoke or catch fire, keep the oven door closed to stifle the flames, turn the oven off at the wall switch, or shut the power off at the fuse or circuit-breaker panel.
- The microwave is intended for heating food and beverages. Drying of food or clothing and heating of warming pads, wheat bags, slippers, sponges, damp cloth and similar may lead to risk of injury, ignition or fire.
- Heat from the contents of a container may be transmitted to the container itself, so please be careful when removing it from the oven. Please remember that the food or liquid inside may be releasing some steam or may be spitting. Never cover any container fully, always leave a gap for steam to escape.
- Cooking utensils may become hot because of heat transferred from the heated food. This is especially true if plastic wrap has been covering the top and handles of the utensil. You may need oven gloves to handle the utensil.
- Ensure you do not use any corrosive chemicals or vapours in the appliance. It is not designed for industrial or laboratory use.
- Never put any objects into the openings on the outer case.
- On the right hand side wall of the cavity is the wave guide cover, microwaves are passed through this to enable your food to cook. It is important that this wave guide cover is kept clean at all times. To do this wipe with mild detergent and water, then dry.
- When removing the turntable support of the oven, make sure you put it back properly.
- If the inside of the oven smells, put a cup of water with the juice and skin of one lemon in a deep microwave bowl. Microwave it for three minutes, wipe thoroughly and then dry with a soft cloth.
- Do not try to deep-fry foods in this oven.
- Do not use metal pans or dishes with metal handles.
- Do not use anything with a metal trim.
- Do not use paper covered wire twist-ties on plastic bags.
- Do not use melamine dishes as they contain a material which will absorb microwave energy. This may cause the dishes to crack or burn, and will slow down the cooking speed.
- Use only cookware that is approved to be used in a microwave oven.
- Do not cook using containers with restricted openings, such as bottles, as they may explode.
- Do not heat baby bottles with the teat left on. Remove it if replacing the bottle back into the oven.
- Do not use the microwave oven for heating utensils.
- Do not use the oven for any reason other than preparing food, such as for drying clothes, paper or any other non-food items, or for sterilising purposes.
- Do not store anything in the oven, such as

paper, or cook books .

- Do not cook any food surrounded by a membrane, such as egg yolks, potatoes, chicken livers, sausages, ready meals and so on without piercing them several times with a fork.
- Never put any objects into the openings on the outer case.
- You should use microwave utensils only in line with these instructions.
- Only use the accessories supplied by the manufacturer.

Microwaves are high-frequency electromagnetic waves similar to radio waves. While radio waves may vary in length from one metre to many kilometres, microwaves are very short (less than 12.5 centimetres). Microwaves do not make any heat themselves but only cause water molecules in food to vibrate. This vibration produces heat that cooks the food. This is why your food will come out of the microwave piping hot, when your utensils inside the oven stay much cooler. The microwaves do not stay in the air or in the food when you open the microwave oven door.

The microwave oven will work using an ordinary household electrical socket. Inside the microwave oven is the magnetron, which turns the electrical energy into microwaves.

Microwaves cannot go through metal, so the inside of the oven is lined with metal. The door is lined with a fine metal mesh which stops microwaves getting through. This means that when the microwave oven door is shut, there is no possibility that microwaves can be released. This is why the microwave oven has been made so that it will not work when the door is open.

PRODUCT OVERVIEW

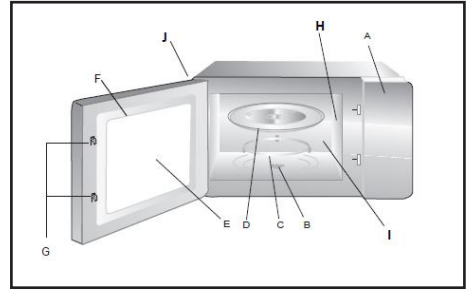

- A. Control panel (including door release button)
- B. Turntable shaft
- C. Turntable ring assembly
- D. Glass turntable
- E. Observation window
- F. Door assembly
- G. Safety interlock latches
- H. Wave guide cover
- I. Oven cavity
- J. Ventilation slots

CONTROL PANEL

MENU ACTION SCREEN

Cooking time, power, auto, and the clock time are displayed.

POWER

Press to select the power level for microwave cooking. Press the Left Hand Side of the button.

WEIGHT/TIME DEFROST

Press this button to input weight for defrosting. Press the Right Hand Side of the button.

CLOCK/PRE SET Press this button to set the clock and use the preset function.

STOP/CLEAR Press to stop the cooking process, press the RHS.

TIMER/WEIGHT/AUTO MENU Rotate to select the cooking time and the auto menus.

START/+30SEC/CONFIRM Press this button to start the cooking process and confirm when programming.

DOOR OPEN Pull the handle to open the door.

CLOCK SETTING

When the microwave oven is first turned on, the oven will display "0:00", the buzzer will ring once.

- 1) Press **"-SET"** to choose hours or minutes for alteration. The hour figures will flash. When altering the hours the "0" on the Left Hand Side will flash.
- 2) Turn the dial to adjust the hour figures, 0 - 23 (this is a 24-hour clock).
- 3) Press **"CLOCK/PRE-SET"** button again and the minute figures will flash.
- 4) Turn the dial to adjust the minute 0 - 59 (60-minutes).
- 5) Press **"CLOCK/PRE-SET"** to finish the clock setting procedure. The ":" will then flash. Note: the input time should be within figures, the input time should be within **"TIMER/WEIGHT/AUTO MENU"** **"TIMER/WEIGHT/AUTO MENU"** **"CLOCK/PRE"**



- 1) If the clock is not set, some features of the microwave oven will not operate.
- 2) During the process of clock setting, if you press **"STOP/CLEAR"**, the oven will go back to the previous status.

1) Press the **"POWER"** button once, and **"P100"** and flash.

2) Turn the **"TIMER/WEIGHT/AUTO MENU"** to select the microwave **"P80"**, **"P50"**, **"P30"**, **"P10"** will display in order.

or

Press the button to scroll through the power levels.

3) Press **"START/+30SEC/CONFIRM"** to confirm.

4) Turn the **"TIMER/WEIGHT/AUTO MENU"** dial to adjust the cooking time (The time setting should be between 0:05- 95:00.)

5) Press **"START/+30SEC/CONFIRM"** to start the cooking process.

Press power button	Cooking power	Equivalent power rating
P100	100%	800 W
P80	80%	640 W
P50	50%	400 W
P30	30%	240 W
P10	10%	80 W

To stop the cooking process at anytime press the **"STOP/CLEAR"** button

SPEEDY COOKING

Press the **"START/+30SEC/CONFIRM"** button to microwave cook at 100% power level for 30 seconds.

The microwave will start cooking immediately. Each press on the same key will increase the cooking time by 30 seconds. The maximum cooking time is 95 minutes.



Note: this function does not work for defrost and auto menu .

Alternately turn the **"TIMER/WEIGHT/AUTO MENU"** dial to adjust the desired cooking **"START/+30SEC/CONFIRM"**.

The oven will start cooking for the selected length of time at 100% power.

DEFROSTING BY WEIGHT

1) Press **"WEIGHT/TIME DEFROST"** button once, the oven will display **dEF1"**.

2) Turn the **"TIMER/WEIGHT/AUTO MENU"** dial to select the weight of the weight should be set between 100-2000g.

3) Press **"START/+30SEC/CONFIRM"** button to start defrosting.

DEFROSTING BY TIME

1) Press **"WEIGHT/TIME DEFROST"** button twice, the oven will display **"dEF2"**.

2) Turn the dial **"TIMER/WEIGHT/AUTO MENU"** to select the defrosting time, the maximum time is 95 minutes.

3) Press **"START/+30SEC/CONFIRM"** button to start defrosting. The defrosting power is 30%, and cannot be changed.

MULTI-STAGE COOKING

To set a maximum of two different stages. For instance, to defrost an item and the follow it with the cooking cycle.



The auto menu cannot be set as one of the multi-stage cooking functions.

Example: if you want to defrost 500g of food, then cook it at 80% microwave power for 7 minutes. The steps are as follows:

- 1) Press button once, the screen will display **"dEF1"**
- 2) Turn the dial to adjust the defrost ;
- 3) Press the button once;
- 4) Turn the dial to choose 80% microwave
- 5) Press **"START/+30SEC/CONFIRM"** to confirm;

6) Turn the "TIMER/WEIGHT/AUTO MENU" dial to adjust the cooking time to 7 minutes; 7) Press the "START/+30SEC/CONFIRM" button to start the cooking process.

PRE-SET TIME TO START FUNCTIONS

Set the clock first. (Consult the instructions for setting the clock) Input the cooking program. It's possible to input a maximum of 2 cooking stages. Do not use the defrost function in the pre-set function. The auto menu can be set for a single stage only.

Example: if you want to cook with 80% microwave power for 7 minutes, to start at a given time.

- 1) Press the "POWER" button once;
- 2) Turn the "TIMER/WEIGHT/AUTO MENU" dial to choose 80% microwave power till "P80" is displayed;
- 3) Press "START/+30SEC/CONFIRM" button to confirm;
- 4) Turn the "TIMER/WEIGHT/AUTO MENU" dial to adjust the cooking time to 7 minutes;
- 5) After the above steps, DO NOT press "START/+30SEC/CONFIRM" button, but do as follows :
- 6) Press the "CLOCK/PRE-SET" button, the current time displays and the hour figures flash.
- 7) Turn "TIMER/WEIGHT/AUTO MENU" dial to adjust the hours, the input should be within 0-23. Press "CLOCK/PRE-SET" button and the minute figures will flash. Turn the "TIMER/WEIGHT/AUTO MENU" dial to adjust the minutes, the input time should be within 0- 59. This sets the start time.
- 8) Press "START/+30SEC/CONFIRM" to finish setting.

The ":" will illuminate, the buzzer will ring twice when the time to start arrives, and then cooking will start automatically.



The clock must be set first. Otherwise, the pre-set function will not work.

AUTO MENU

The microwave can automatically calculate the cooking time based on the type of food and weight.

- 1) Turn the "TIMER/WEIGHT/ AUTO MENU" dial clockwise, "A-1" will display on the screen. Continue to rotate the dial to access the other auto selections, up to A-8.
- 2) Press the "START/+30SEC/CONFIRM" button to select the chosen auto, A-1 - A-8.
- 3) Turn the "TIMER/WEIGHT/AUTO MENU" dial to choose the food weight, these are pre-set and listed below.
- 4) Press "START/+30SEC/CONFIRM" button to start cooking. Please see the table below for the various settings.

Display	Auto Menu	Weight (g) on the Display	Power
A-1	Reheat	200	100%
		400	
		600	
A-2	Vegetable Add water.	200	100%
		300	
		400	
A-3	Fish	250	80%
		350	
		450	
A-4	Meat	250	100%
		350	
		450	
A-5	Pasta	50(add 450ml water)	80%
		100(add 800ml water)	
A-6	Potato	200	100%
		400	
		600	
A-7	Pizza	200	100%
		400	
A-8	Soup	200	80%
		400	

In all cases allow the food to stand in the microwave for 1-2 minutes after the cooking cycle is complete.

CHECKING FUNCTIONS

- 1) During the cooking cycle, press the "POWER" button and the current power will be displayed for 2-3 seconds.
- 2) In pre-set state, press the "CLOCK/PRE-SET" button to check the time when the cooking will start. The pre-set time will flash for 2-3 seconds, then the oven will turn back to the clock display.
- 3) During the cooking cycle, press the "CLOCK/PRE-SET" button to check the current time. It will be displayed for 2-3 seconds.

CHILD LOCK

Lock on: In standby, when nothing is operating, Press "STOP/CLEAR" button for 3 seconds, there will be a long "beep" as the lock activates. A rectangle will illuminate in the display.

Lock off: In locked state, press "STOP/CLEAR" button for 3 seconds, there will be a long "beep".

The current time will continue to display.

When the child lock is on, no functions can be activated.

GENERAL INFORMATION

- The buzzer will sound once when turning the knob at the beginning;
- The "START/+30SEC/CONFIRM" button must be pressed again to continue cooking if the door is opened during a cooking cycle.
- Once the cooking programme has been set, if the "START/+30SEC/CONFIRM" button is not pressed in 1 minute. The current time will display and the setting will be cancelled.
- The buttons will beep if they are pressed correctly, if not pressed correctly they will not beep.
- The buzzer will sound five times to remind you when cooking is finished.

IMPORTANT UTENSIL INFORMATION

- Do not use metal pans or dishes with metal handles.
- Do not use anything with a metal trim.
- Do not use paper covered wire twist-ties on plastic bags.
- Do not use melamine dishes as they contain a material which will absorb microwave energy. This may cause the dishes to crack or burn, and will slow down the cooking speed.
- Use only cookware that is approved to be used in a microwave oven.
- Do not cook using a container with a restricted opening, such as bottles, as they may explode.
- Do not heat baby bottles with the teat left on. Remove it if replacing the bottle back into the oven.
- Only use thermometers that are approved for microwave ovens.
- Do not use the microwave oven for heating utensils.

CLEANING AND CARE

- Before you clean the oven, turn it off and unplug it.
- Keep the inside of the oven clean. When food or liquids stick to the oven walls, wipe with a damp cloth. We recommend that you do not use harsh detergent or abrasives.
- On the right hand side wall of the cavity is the wave guide cover, microwaves are passed through this to enable your food to cook. It is important that this wave guide cover is kept clean at all times. To do this wipe with mild detergent and water, then dry.
- You should clean the outside of the oven with a damp cloth. Don't allow water to seep into the ventilation openings.
- Do not allow the control panel to become wet. Clean with a soft, damp cloth. Do not use detergents, abrasives or spray-on cleaners on the control panel.
- If steam builds up inside or around the outside of the oven door, wipe with a soft cloth. This may happen when the microwave oven is used in humid conditions.
- Regularly remove the glass turntable to clean it, and wash it in warm soapy water. Regularly clean the turntable support and oven floor. Simply wipe the bottom surface of the oven with mild detergent and water, then dry. You can wash the turntable support in mild soapy water.
- When removing the turntable support of the oven, make sure you put it back properly.
- If the inside of the oven smells, put a cup of water with the juice and skin of one lemon in a deep microwave bowl. Microwave it for three minutes, wipe thoroughly and then dry with a soft cloth.
- Failure to maintain the oven in a clean condition, especially if liquid is left under the turntable, could lead to deterioration of the surface that will adversely affect the life of the appliance that may result in a hazardous condition.

GUARANTEE

This product is guaranteed for 12 months from the date of the original purchase. If any defect arises due to faulty materials or workmanship the faulty product must be returned to the place of purchase. Refund or replacement is at the discretion of the store.

The following conditions apply:

- The product must be returned to the retailer with the original proof of purchase.
- The product must be installed and used in accordance with the instructions contained in this instruction guide and any other instructions for use which has been supplied.
- It must be used for domestic purposes only and for its intended use.
- This guarantee does not cover wear and tear, damage, misuse or consumable parts.

This does not affect your statutory rights.

Produced for;
G2S Ltd.
Bolton
BL6 5HY

TECHNICAL SPECIFICATION

Rated Voltage

230V - 240V ~ 50Hz

Rated Input Power(Microwave)

1200 -1270 W

Rated Output Power(Microwave)

750-800 W

Oven Capacity

20 L

Turntable Diameter

255 mm

External Dimensions(HxWxD)

315mm x 495mm x 395mm

Net Weight

11.2 kg

CARBON MONOXIDE ALARM

A FireAngel CO-9B battery-operated alarm is fitted near to the ceiling in your caravan.

FEATURES

- An advanced electro-chemical sensor designed to accurately measure low-high levels of carbon monoxide (CO) providing an early warning of toxic CO levels in your caravan.
- Detects carbon monoxide continuously.
- Resistant to false alarms caused by usual household contaminants.
- Sounds a large 85dB alarm (at 1 metre (3 feet)) to alert you in case of an emergency.
- Test/Reset button.
- Simple to mount, portable, ideal for travelling.
- Conforms to the British Standards Institute (BSi) Carbon Monoxide Standard BS EN 50291: 2001.
- 7 year warranty.
- Test the sounder, batteries and circuitry.
- Allows you to test the sensor by introducing a source of CO into the detector.
- Silence the loud 85dB sounder during an alarm (only possible when current CO level is less than 50ppm (Parts Per Million the accepted level of carbon monoxide in the air)).

TESTING THE SOUNDER BATTERIES AND CIRCUITRY

- Test the sounder, batteries and circuitry by pressing and holding the Test/Reset button for 1 second to confirm that the detector is operating properly. The sounder should sound as soon as the button is pressed, and the alarm LED will illuminate red, indicating that the sounder is working and the batteries are providing power to the unit. The test for the sounder batteries and circuitry should be performed weekly.

TESTING THE SENSOR

- All sensor testing should be carried out by a responsible adult. This test should only be performed once a month. Excessive testing will cause the battery life to be shortened.



CO testers may be used in order to avoid having to burn cigarettes, incense sticks etc.



Please read all steps thoroughly before attempting to test your alarm.

- If the alarm is wall mounted, remove by unhooking the unit from the wall fixing screws.
- Cover the sounder vents with one hand and hold the Test/Reset button down with your thumb/finger until the power LED illuminates green and the sounder sounds for a second time. (This should happen after 5 seconds.) Release the Test/Reset button and the power LED will flash green once every second. This indicates that the sampling rate of the detector has increased and can be tested using a known source of CO.
- Light an incense stick or a cigarette using a match or a lighter. If using an incense stick, be sure to blow the flame out so that the incense stick is smouldering. Extinguish the lighter, or put out the match and place it into a dish of water.
- Turn the detector on its side so that the vents on the right hand side of the detector are pointing downwards. Hold the burning incense stick or cigarette around 15cm (6") below the detector. An increase in the localised carbon monoxide level within the sensor to more than 50ppm will cause the sounder to sound for one cycle of four loud beeps. The power LED will no longer flash green every second but will revert to flashing once a minute. The detector will revert back to the ordinary operating mode (it may take up to 2 minutes for the localised level of carbon monoxide to fall below 50ppm). Now move the source of CO away from the detector as the test is finished.
- Put out the incense stick or cigarette by placing it into a dish of water. Ensure all flames have been extinguished.



If the localised carbon monoxide level within the sensor does not reach 50ppm during the test, the sensor test will stop automatically after 3 minutes.

UNDERSTANDING YOUR PRODUCT'S INDICATORS

The higher the concentration of carbon monoxide detected by the detector, the quicker it will respond. When sufficient carbon monoxide is detected a loud audible signal

(85dB at 1m/3ft) will be emitted and the alarm LED will flash red once every second.

The alarm will sound:

- Between 60 and 90 minutes when exposed to 50ppm of CO.
- Between 10 and 40 minutes when exposed to 100ppm of CO.
- Within 3 minutes when exposed to 300ppm or more CO.
- There will be an audible "chirp" if the battery, sensor or circuitry has any fault including a low battery. This sound will continue once a minute for 30 days. (The battery must be replaced to ensure occupant safety.)
- If the device continues to chirp despite having new batteries and the product is still in warranty then contact technical support for the device. If the device is no longer in warranty replace it immediately.

MAINTAINING AND TESTING YOUR DETECTOR

Your detector will alert you to potential hazardous CO concentrations in your caravan when maintained properly. To maintain your FireAngel detector in proper working order and to ensure that the sensors will last for the lifetime of the product, it is recommended that you:

- Test the sounder, batteries and circuitry of your detector once per week by pressing and holding the Test/Reset button for 1 second.
- Keep the detector free of dust by gently vacuuming with a soft brush attachment when required.

To prevent the possibility of contaminating the sensor in your detector and thus affecting its reliability:

- Never use cleaning solutions on your detector. Simply wipe with a damp cloth.
- Do not paint the detector.
- Do not spray aerosols on or near to the detector.
- Do not use any solvent based products near to the detector

Failure of any test should be reported to the manufacturer's technical support line.

+44 (0)800 141 2561



Do not attempt to repair your CO detector. Do not remove any screws or open the main casing of your detector. Any attempt to do so may cause malfunction and will invalidate the warranty.

WHAT TO DO IN THE EVENT OF AN ALARM

- Keep calm and open all the doors and windows to ventilate your caravan.
- Stop using all fuel burning appliances and ensure where possible they are turned off.
- Evacuate the caravan leaving doors and windows open.
- Do not re-enter the caravan until the alarm has stopped.
- Get medical help for anyone suffering the effects of CO poisoning and advise that CO poisoning is suspected.
- Do not use the caravan again until you have had a full service of all appliances by your supplying retailer. In the case of gas appliances they must be tested by a GAS SAFE registered installer. Please contact your Bailey retailer for more details.
- The electro-chemical sensors used in the carbon-monoxide alarm have a limited lifespan-therefore it is recommended that a CO alarm is replaced every 5-7 years after manufacture or in accordance with the unit's instructions. Check the manufacturing date on the alarm's label.

BATHROOM CARE

Do not expose the bathroom plastic fittings to cleaning products or abrasive material containing concentrated perfumes, body oil, linseed oil, gritty or abrasive substances, solvents (white spirits, antifreeze etc). These may cause permanent damage to the material. Always clean the bathroom straight away after use with warm soapy water and a soft cloth. Stubborn stains may be removed with a solution of lemon juice and water, at a solution of 1 part water to 1 part lemon juice.

Thetford bathroom cleaner is suitable for cleaning the shower and vanity unit plastic items (sinks, shower trays, Thetford toilets etc).



Domestic cleaning products are not to be used to clean the shower/vanity unit plastic items. Some mouthwash can cause plastic items to crack and for this reason should not be used.

BATHROOM SHOWER TAP

Your shower tap has a high quality finish and should be treated with care to preserve the visible surfaces.

All surface finishes will wear if not cleaned correctly; the only safe way to clean your mixer is to wipe with a soft damp cloth.

Stains can be removed using washing up liquid. All bathing powders and liquids will damage the surface of your fitting, even the non-scratch cleaners.

MIRRORS

Cleaning: it is best to clean mirrors with a cleaner that does not contain ammonia. If you are not sure of the ingredients, spray a clean lint-free cloth with the cleaner so as not to get the liquid near to the edge of the mirror which is where ammonia would cause the most harm.

- Use a soft, dust-free cloth.
- Warm water- try bottled water if your tap water is mineral rich.
- For stubborn dirt use an oil free steel wool pad, carefully and precisely.
- Spray cleaners on your cloth, not directly onto the mirror.
- Keep the mirror frame dry.
- Never use a razor blade on a mirror, even if the mirror has paint specks on it. Always use hot water first.
- If you find black spots on your mirror you

may have damaged the silvering behind the mirror's glass. If this is the case you may be able to cover the spots from the front.

- Moisture along a mirror's edge can seep in and harm the reflective backing.
- Keep in mind that long-term exposure to direct sunlight may damage some mirrors.

ECOCAMEL SHOWER HEAD

Your caravan is fitted with an Ecocamel shower head.

- It saves water, energy and money.
- It has a wipe clean head to prevent the build-up of lime scale.
- Uses a maximum of 8 litres a minute.

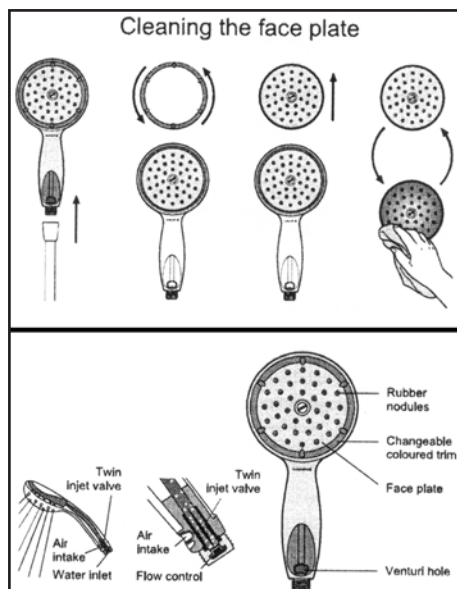

After showering (when the shower is turned off) your Ecocamel shower head simply drains off any excess water through the air intake. Clean your Ecocamel shower head with a damp cloth. Do not use any abrasive or chemical cleaners. Should any scale build up on your shower head's spray plate you can de-scale it by rubbing the nozzles with your thumb.

The Ecocamel shower head will fit all caravan showers and is available from the Bailey Parts department.

THETFORD TOILET

The toilet is made up of two parts:

- A permanently fixed toilet bowl.
- A waste holding tank that is accessible from the outside. The removable waste holding tank is located under the toilet bowl and can be removed via a door on the outside of the caravan. The Thetford Cassette Toilet is the solution to the sanitary problem in your caravan.

These operating instructions cover Thetford Cassette Toilet C260/262CWE.

Please note that on some models the cistern is not visible.

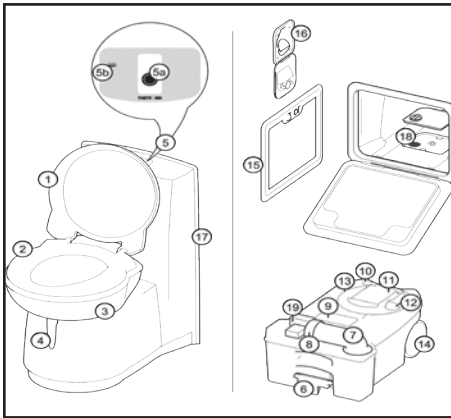

PARTS

1. Cover
2. Seat
3. Swivelling toilet bowl
4. Blade handle to open and close blade
5. Control panel
- 5a. Electric flush button
- 5b. Waste holding tank level indicator
6. Pull handle
7. Pour out spout
8. Cap with measuring cup
9. Automatic pressure release vent
10. Vent button
11. Sliding cover
12. Blade opener
13. Waste holding tank mechanism
14. Wheel
15. Service door
16. Water fill door
17. Console with flush-water tank
18. Filter for electric ventilator
19. Location waste pump-out system

USING THE TOILET (STANDARD)

1. Turn the bowl to the desired position with the lid closed and using both hands.
2. To activate the control panel, press the flush-button once. The control panel display will stay activated for approximately 5 minutes. Run some water into the bowl by pressing the flush button again briefly.
3. The toilet may be used with the blade open or closed. To open the blade, slide the blade handle under the toilet bowl sideways. After use, open the blade (if still closed) and flush the toilet by pressing the flush button for several seconds (if necessary re-activate the control panel). Close the blade after use. If your toilet has its own flush-water tank, please make sure that you do not travel with a flush-water tank that is too full. Do not travel with water in the toilet bowl. Failure to adhere to this notice may result in water damage to your caravan.

CLEANING AND MAINTENANCE

- The toilet should be cleaned and maintained regularly, depending on the amount of use. To clean Thetford toilets, we advise using water and Thetford Bathroom Cleaner. Never use bleach, vinegar or other powerful household cleaners that contain these substances. These may cause permanent damage to the seals and other toilet components.

TOILET BOWL

1. Squirt Thetford Bathroom Cleaner into the toilet bowl.
2. Flush the toilet bowl with water and wipe down the rest of the toilet with a damp cloth.
3. Clean seat and lid. The seat and lid can easily be removed: lift the seat and lid assembly and pull the round pins (inside the assembly) outwards from the pin holes. After cleaning, replace the seat and lid by positioning the round pins in front of the pin holes and push the lid and seat downwards.
4. To keep your flush-water fresh and to prevent deposits forming in your toilet bowl, add a correct dosage of Aqua Rinse in your flush water tank.

WASTE HOLDING TANK

To keep your waste holding tank fresh and clean, Thetford has developed a number of different toilet fluids. Thetford toilet fluids suppress smells, reduce formation of gas, promote breakdown of toilet waste and increase the life span of a mobile toilet. We advise a thorough cleaning of the waste holding tank once each season.

For the periodical cleaning of the waste holding tank of your toilet, we suggest the following:

1. Remove the removable mechanism from the waste holding tank by turning it anti-clockwise and rinse it under a tap.
2. Remove the cover plate from the automatic pressure release vent by prising it up using a small screwdriver. Use one hand to push the automatic pressure release vent open while holding the float of the automatic pressure release vent on the inside of the tank with the other hand. Push the float upwards, turn it 180 degrees and remove it from below. Remove the rubber seal underneath the float. Rinse the float and rubber seal under a tap. Replace the rubber seal and float for the automatic pressure release vent using the same method in reverse.
3. The rubber seals in the toilet (the lip seal, the mechanism seal, the automatic pressure release vent seal and the cap seal) should be regularly cleaned with water and treated with Thetford High Grade Seal Lubricant. This will ensure that the seals remain flexible and in good condition. If the toilet is not to be used for any length of time, it is important to treat the seals with Thetford High Grade Seal Lubricant after cleaning.



Never use Vaseline or any vegetable oil except olive oil. These may cause leakage or malfunction. The lip seal is a part of the toilet that is subject to wear. Depending upon the extent and manner of use, the seals will become less effective and will need replacing periodically.

WINTER OPERATION

You can use your Thetford Cassette Toilet as normal in cold weather as long as the toilet is situated in a heated location. If there is a risk of freezing we advise that the toilet is drained. For environmental reasons the use of antifreeze, such as that used in car radiators, is not recommended.

PREPARING WASTE HOLDING TANK

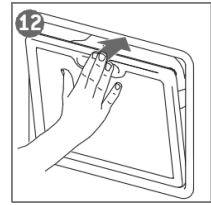
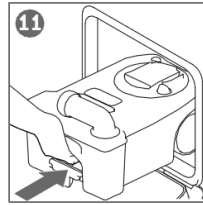
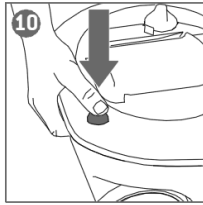
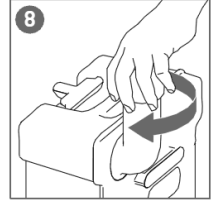
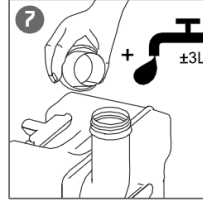
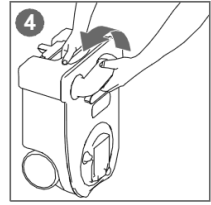
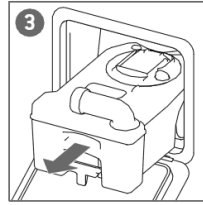
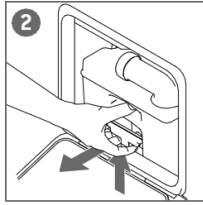
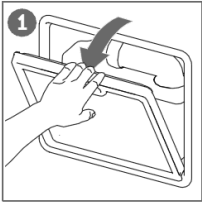

EMPTYING WASTE HOLDING TANK

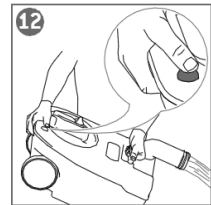
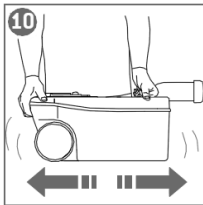
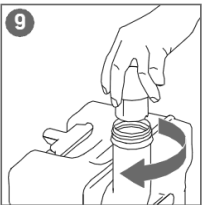
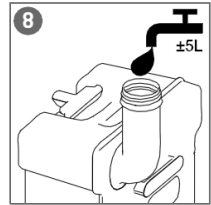
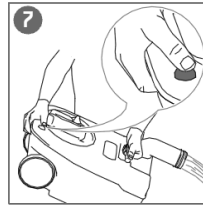
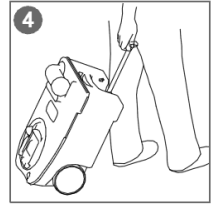
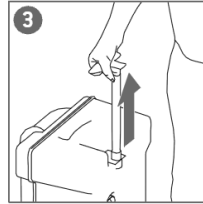
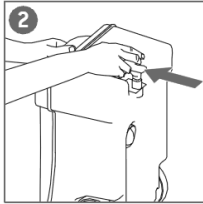
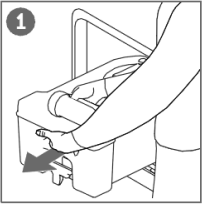

REFRIGERATOR OPERATION

The refrigerator is equipped to operate on three power modes:

- Mains voltage (230v AC)
- Direct-current voltage (12v DC)
- Gas (liquid gas propane/butane).

When the appliance is first put into operation, there may be a mild odour which will disappear after a few hours.

Park the vehicle level, particularly when starting up the refrigerator and filling with food before starting a journey.

The cooling unit is silent in operation.

The refrigerator will take several hours to reach its operating temperature in the cooling compartment. The freezer compartment should be cold about one hour after switching on the refrigerator.

CLEANING

Before starting up the refrigerator it is recommended that you clean it inside and repeat this at regular intervals. Use a soft cloth and lukewarm water with a mild detergent. Always dry thoroughly. Keep the condensation water drain channel free of deposits. To avoid material alterations, do not use soap or hard, abrasive or soda-based cleaning agents. Do not allow the door seal to come into contact with oil or grease.

MAINTENANCE

In compliance with the applicable regulations, please note that the gas unit and the connected ventilation ducts must be checked by authorised technical personnel after first use and after every other year for compliance with the European Standard EN 1949. A test certificate has to be issued. It is the user's responsibility to arrange this test. The gas burner must be inspected and cleaned as necessary at least once a year. When using liquefied petroleum gas (tank or refill cylinders) the maintenance interval is reduced to half yearly or quarterly. Keep the evidence of maintenance work carried out on your refrigerator. Work on gas and electrical equipment shall be carried out by qualified personnel only.

DEFROSTING

As time goes by, frost builds up on the fins inside the refrigerator. A layer of frost thicker on one side may occur and does not represent a malfunction. When this layer of frost is about 3 mm thick, the refrigerator should be defrosted.

1. Switch off the refrigerator, as described in section Shutting off the refrigerator.
2. Remove all food and the ice cube tray.
3. Leave the refrigerator door open to allow air to enter and to prevent formation of mildew.
4. After defrosting (freezer compartment and fins free of frost) wipe both cooling compartments dry with a cloth.



Water thawing in the main compartment of the refrigerator runs into an appropriate container at the back of the refrigerator. From there, the water evaporates.

ENVIRONMENTAL NOTICES

Ammonia (a natural compound of hydrogen and nitrogen) is used in the cooling unit as a coolant. Non-ozone-hazardous cyclopentane is used as a propellant for manufacturing PU foam insulation.

Do not dispose of batteries in domestic waste. Take your used batteries to a collection point.

ENERGY SAVING TIPS

- At an average ambient temperature of 25°C, it is sufficient to operate the refrigerator at middle thermostat setting. Where possible, always store pre-cooled products.
- Do not expose the refrigerator to direct sunlight or any other heat source (e.g. heater).
- Ensure that air circulation of the refrigeration unit is not obstructed.
- Arrange the shelves evenly in the refrigerator (in the cooling compartment) in order to achieve the most efficient use of energy. Do not overfill the storage grids and compartments to prevent obstructing the internal air circulation.
- Maintain a clearance of approx. 10 mm between chilled products and post-evaporator 'cooling fins'.

- Defrosting at regular intervals saves energy (see section Defrosting).
- Open the refrigerator door only for a short period of time when removing products.
- Run the refrigerator for about 12 hours before filling it.

DECLARATION OF CONFORMITY

The current Declaration of Conformity can also be requested directly from Dometic GmbH, Siegen.

SAFETY INSTRUCTIONS

APPLICATION ACCORDING TO REGULATIONS

This refrigerator is designed for installation in recreation vehicles such as caravans.

The refrigerator is to be used solely for storing foodstuffs.



The refrigerator is not suitable for the proper storage of medication. Please observe in addition the instructions in the medication package inserts.

USERS RESPONSIBILITY

Anyone operating the refrigerator must be familiar with the safe handling and understand the advice in these operating instructions.

This appliance is not intended for use by persons (including children) with reduced physical, sensory or mental capabilities, or lack of experience and knowledge, unless they are supervised or have been given instruction concerning use of the appliance by a person responsible for their safety. Children should be supervised to ensure that they do not play with the appliance. Cleaning and user maintenance shall not be completed by children.

WORKING UPON AND CHECKING THE REFRIGERATOR



Work on gas equipment, exhaust system and electrical facilities must be carried out by authorised personnel only. Substantial damage to property and/or injury to persons can arise through unprofessional procedures.



Never use an unshielded flame to check gas bearing parts and pipes for leakage. This is a danger of fire or explosion.



Never open the absorber cooling unit. It is under high pressure. There is a danger of injury.

INFORMATION ON COOLANT

Ammonia is used as a coolant. This is a natural compound also used in household cleaning agents (1 litre of Salmiak cleaner contains up to 200g of ammonia, about twice as much as used in the refrigerator). Sodium chromate is used for corrosion protection (1.8% by weight of the solvent).

In the event of leakage (easily identifiable from the strong odour), proceed as follows:

- Switch off the appliance.
- Air the room thoroughly.
- Inform authorised customer services.



For your safety it was ascertained in an expert's report that no impairment of health exists when the coolant is discharged.

APPLIANCES WITH ELECTRONICS (MES/AES)

Car manufacturers often use a battery management system, which provides the caravan with constant voltage in trailer mode. If the car and trailer remain parked for more than 30 minutes with the engine switched off, the battery management system automatically switches off the permanent positive supply to the caravan (to prevent the battery from discharging). Fridges with control electronics (MES/AES) are then inoperative.

Check whether your drawing vehicle is equipped with a battery management system.

A permanent 12v power supply must be guaranteed for operation of the MES/AES fridges.

OPERATING THE REFRIGERATOR WITH GAS

It is imperative that the operating pressure of the pressure reducer on the gas system corresponds to the data specified on the rating plate of the refrigerator. Compare the operating pressure of the rating plate with the data specified on the pressure reducing valve of the liquid gas cylinder.



Dometic refrigerators are equipped for a connection pressure of 30mbar.

Operating appliance with Gas is not permitted

- At petrol stations
- On ferry boats, and on board motor rail trains
- While transporting the caravan by transporter or breakdown vehicle

IF YOU SMELL GAS

- Open all windows and leave the room.
- Do not operate any electrical equipment and prevent the use of naked flames.
- Do not operate any electrical equipment and prevent the use of naked flames.
- Contact authorised specialist personnel for advice.

SAFETY INSTRUCTIONS WHEN STORING

FOODSTUFFS

No refrigerator of any kind can improve the quality of the food; refrigerators can only maintain the food's quality for a short duration as from the time of storing it.

Please observe the following particular conditions for storing food in a refrigerator that is built into a vehicle:

- A change in the climatic conditions such as temperature fluctuations.
- High temperatures inside the vehicle when it is closed and parked in direct sunlight (temperatures are possible up to 50°C).
- A refrigerator built in behind a window and exposed to direct sunlight.
- Storing the products too soon, i.e. shortly after starting up the appliance for use.
- Use of the refrigerator during travel with the power supply of 12v DC.
- Fluctuations in the power supply at the parking place when using the energy type 230v AC (mains voltage).

Under these particular conditions the refrigerator cannot guarantee reaching the temperature needed for perishables.

Perishables include all products with a stipulated use-by date and a minimum storage temperature of +4°C or less, especially for meat, poultry, fish, sausages, pre-packed foods.

- Pack raw and cooked foods separately (e.g. in containers, aluminium foil, etc.).
- Only remove the outside packaging of single packs if all the necessary information, e.g.

the use-by date, can also be read on the single packs.

- Please observe the instructions and information regarding the use-by date on the outside packaging of the food.
- Do not leave cooled goods outside the refrigerator for too long.
- Place the foods with the next use-by date at the front, accordingly.
- Pack away any left-over food and eat at the first opportunity.
- Wash your hands before and after handling any food.
- Regularly clean the inside of the refrigerator.
- Please observe section Cleaning of this instruction.



The cooling unit's performance is influenced by ambient temperatures. Please select the medium setting for ambient temperatures between +15°C and +25°C (refer to Setting of cooling compartment temperature). The unit operates within its optimum performance range.

Dometic refrigerators work according to the absorption principle. For physical reasons, an absorption system responds slowly to changes made by the thermostat controller, by loss of cooling energy through opening the door or during storing food. The devices meet the cooling performance requirements of the Climatic Class SN acc. to EN/ISO 7371 in the temperature range of +10°C to +32°C ambient temperature.

Cold air can restrict the performance of the unit. Install the winter covers if you discover any loss of cooling performance when outdoor temperatures are low (see Operation during low outside temperatures). For ambient temperatures exceeding +32°C for a longer period of time, it is recommended installing Dometic additional fan.

REFRIGERATOR OPERATION

The refrigerator is equipped to operate on three power modes:

- Mains voltage (230v AC)
- Direct-current voltage (12v DC)
- Gas (liquid gas propane/butane)

Select the desired power mode by the energy selector switch (battery igniter type

models) or the energy selector button (MES, AES). Appliances with automatic energy selection (AES) are additionally provided with "automatic mode" function. Then the AES system automatically selects the best energy source for each particular situation.

- When the appliance is first put into operation, there may be a mild odour which will disappear after a few hours.
- Park the vehicle level, particularly when starting up the refrigerator and filling with food before starting a journey.
- The cooling unit is silent in operation.
- The refrigerator will take several hours to reach its operating temperature in the cooling compartment. The freezer compartment should be cold about one hour after switching on the refrigerator.

- On the initial refrigerator start-up or after a cylinder change, air may be trapped in the gas line. To purge the air from the lines, switch on the refrigerator and any other gas appliances (e.g. stove) for a short time. The gas ignites without delay.
- Each refrigerator with manual ignition is equipped with an automatic flame safety valve which interrupts the gas supply automatically after approx. 30 seconds when the flame has extinguished.



As a basic rule, gas operation is prohibited in petrol stations



We recommend maintenance following an extended shut-down of the vehicle. Please contact our customer services.

ELECTRICAL OPERATION

12V VOLTAGE (ON BOARD POWER SUPPLY)

The refrigerator should only be used in 12v DC operation whilst the caravan is being towed, otherwise the on-board battery would be discharged within a few hours.

MAINS POWER 230v

This operation should only be selected where the supply voltage of the connection for power supply corresponds to the value specified on the data plate. Any difference in values may result in damage to the appliance.

GAS OPERATION (LIQUID GAS)

- The refrigerator must be operated using liquid gas (propane, butane) (no natural gas or town gas).
- When using LPG gas, please consider that the burner needs cleaning at shorter intervals due to the gas combustion method (2 - 3 times per year recommended).
- In Europe, gas operation is permitted while travelling only on the condition that the gas system of the vehicle is equipped with a hose rupture protection. The national regulations of the respective country must be observed.
- For physical reasons, gas ignition faults could occur starting from an altitude above sea level of approx. 3280ft. / 1000m.

**REFRIGERATOR MODEL RML9330/RM8550/
RMS8550/RM8500 OPERATION**

- 1= Energy selector dial
- 2= Off
- 3= 230v Operation
- 4= 12v Operation
- 5 = Gas Operation

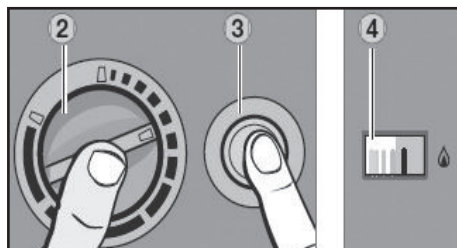
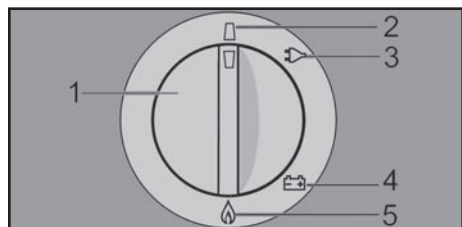

3. Igniter : Press button (3) of battery igniter down and keep it depressed. The ignition process is activated automatically.

4. Once the flame ignites, the pointer of galvanometer (4) begins moving into the green range. The refrigerator is operational. Keep knob (2) depressed for approx. 15 seconds and finally release it.

ELECTRIC OPERATION

Switch on the appliance by turning the energy selection switch (1) clockwise to the desired energy.

- (3) 230v to be used when on site mains
- (4) 12v to be used in transit or off grid



In order to prevent discharge of the on-board battery, 12v operation should only be used while the car is running.

GAS OPERATION

Prior to starting the refrigerator in gas mode:

- Open the gas cylinder valve.
- Open the shut-off valve for gas supply to the refrigerator.

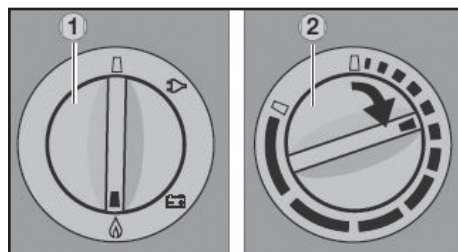

1. Turn the rotary selector switch (1) to the flame position.
2. Turn the temperature selector (2) clockwise, push in and hold. Keep the controller button depressed.

SETTING OF COOLING COMPARTMENT TEMPERATURE

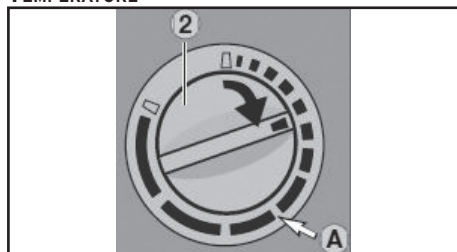

Select the desired cooling compartment temperature by turning the rotary knob (2). The scale starts with MIN position (small bar = highest temperature) and climbs up to MAX position (large bar = lowest temperature).

- Please select the medium setting (A) for ambient temperatures between +15°C and +25°C. The unit operates within its optimum performance range.
- 12v operation: The refrigerator operates without thermostatic control (continuous operation).

Each refrigerator with manual ignition is equipped with an automatic flame safety valve which interrupts the gas supply after approx. 30 seconds when the flame has extinguished. The refrigerator must be operated using liquefied gas (propane or butane NOT natural gas or town gas). When using LPG please

consider that the burner needs cleaning at shorter intervals due to the gas combustion method (annually).

For physical reasons, ignition faults could occur starting from an altitude above sea level of approx. 1,000m/3,280 ft. (This is not a malfunction).

On the initial refrigerator start-up or after a cylinder change, air may be trapped in the gas line. To purge the air from the line, switch on the refrigerator and any other gas appliances (e.g. stove) for a short time. The gas ignites without delay.

LIGHTING

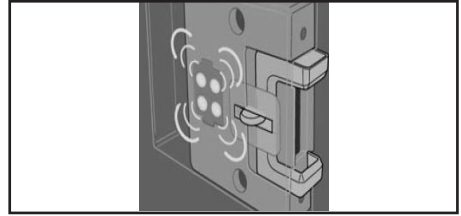

The interior lighting is controlled using a door contact.

Please contact the authorized Dometic Service if a failure occurs.

USING THE DOOR LOCK WHEN PARKING THE VEHICLE

If the vehicle is parked for a longer period of time, the locking hook can be clamped by means of a locking bar.

The door can be opened by pulling it.

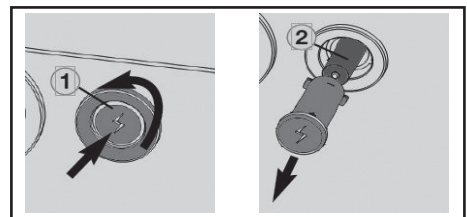
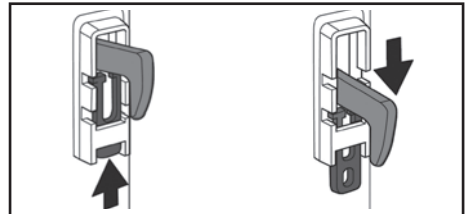

EXCHANGING THE IGNITER'S BATTERY

Unlock the battery by depressing and turning the button (approx. 90° counter clockwise (by means of a suitable screw driver)). After removing the cap, the battery (1.5 V AAA/R3/Micro) can be removed and replaced. Observe correct polarity.

SHUTTING OFF THE REFRIGERATOR

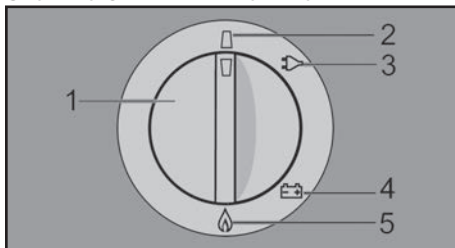

For battery igniter models, set the energy selector switch to position OFF (2). The appliance is switched off.

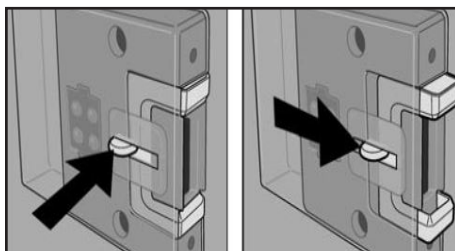

Release the locking mechanism of the door lock by pushing it in and moving to the front. If the door is shut in this position, a small gap is nevertheless kept open to prevent formation of mildew (Fig. 38-39).

If the refrigerator is to be taken out of service for an extended period of time, close the onboard shut-off valve and the cylinder valve.

POSITIONING THE STORAGE RACKS

If it is necessary to remove these storage racks (1) (i.e. for cleaning), first loosen the locking pins (2) as shown with a suitable screwdriver. The storage racks may be pulled out by loosening the two locking devices (3) underneath. For loosening pull the slider to the middle, for fastening pull them sideways.

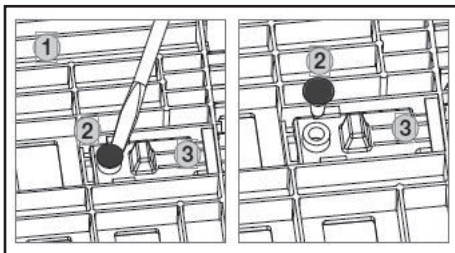

STORING PRODUCTS IN THE COOLING COMPARTMENT

- Switch the refrigerator on approx. 12 hours before filling it.
- Always store pre-cooled foods in the refrigerator. Make sure that the food is well cooled when it is bought and also when transporting it. Use insulated cooling bags.
- Open the refrigerator door only for a short period of time when removing products.
- Products must be packed - best of all in closed containers, wrapped in aluminium foil or similar - and stored separately from each other, in order to prevent drying out or odours.
- Allow foods that have been warmed up to cool down before storing.
- Avoid storing products in the refrigerator that could emit volatile flammable gases.
- Do not overfill the storage grids and compartments to prevent obstructing the internal air circulation.
- Maintain a clearance of approx. 10 mm between chilled products and post evaporator ("cooling fins").
- Do not expose the refrigerator to direct sunlight. Please bear in mind that the temperature inside a closed vehicle increases sharply if exposed to sunlight and that this can reduce the efficiency of the refrigerator.
- Ensure that air circulation of the cooling unit is not obstructed. Keep the ventilation grilles free from obstructions.

REMOVING THE CRISPER

REMOVAL

- Pull out the vegetable bin up to the end top.
- Press in the end stop (1) in both slide rails.
- Remove the vegetable bin.

INSTALLING

- Insert the vegetable bin in the rails and push it in completely.
- After the engagement, the vegetable bin is secured against being pulled out completely again.

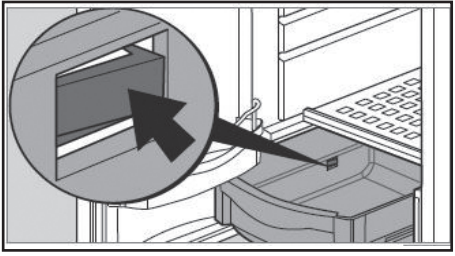

REMOVABLE FREEZER COMPARTMENT

To enlarge the cooling compartment, just remove the freezer compartment.

- Unlock the freezer compartment door using a screwdriver (Fig. 24).
- Remove the freezer compartment door.
- Unlock the freezer compartment shelf on both sides.
- Pull out the freezer compartment shelf.

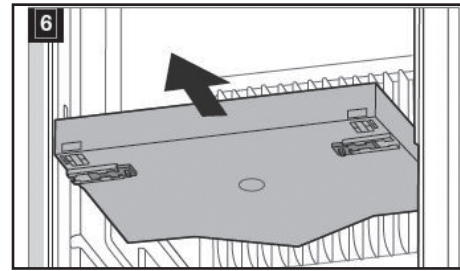
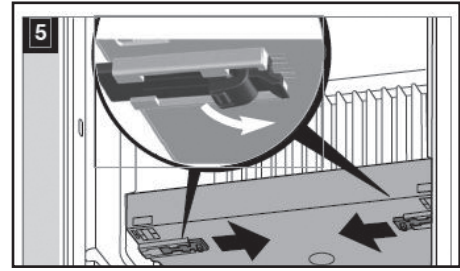
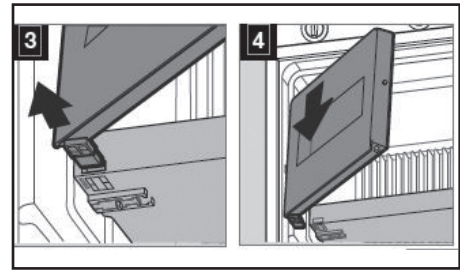
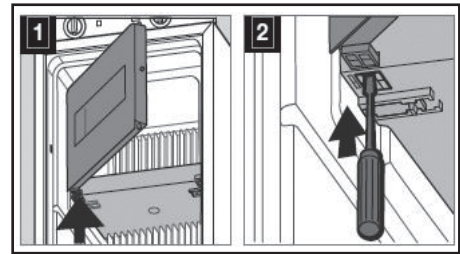

TROUBLESHOOTING

FAILURE: THE REFRIGERATOR DOES NOT COOL SUFFICIENTLY	
Possible Cause	Action you can Take
Inadequate ventilation to the unit	Check that ventilation grilles are not covered
Thermostat setting is too low	Set thermostat to higher level
The condenser is heavily frosted	Check that the refrigerator door closes properly
Too much warm food has been stored inside within a short period of time	Allow warm food to cool down before storage
The appliance has been running for only a short period of time.	Check whether the cooling compartment works after approx. 4-5 hours.
Ambient temperature is too high	Regularly remove ventilation grilles.
FAILURE: THE REFRIGERATOR DOES NOT COOL IN GAS OPERATION MODE	
Possible Cause	Action you can Take
Gas cylinder empty	Change the gas cylinder
Is the upstream shut-off device open?	Open Shut-off valve
Air in the Gas Pipe?	Switch off the appliance and start again. Repeat this procedure 3-4 times, if necessary
FAILURE: THE REFRIGERATOR DOES NOT COOL IN 12V OPERATION	
Possible Cause	Action you can take
On-board fuse defective	Fit new fuse.
On-board battery discharge	Check battery, charge it.
Engine not running	Start engine
Heating element defective (please also refer to failure indication).	Please inform the Dometic Customer Services.
FAILURE: THE REFRIGERATOR DOES NOT COOL IN 230V OPERATION	
Possible Cause	Action you can take
On-board fuse defective	Fit a new fuse.
Vehicle not connected to mains supply voltage	Make connection to a mains power supply
Heating element defective (please refer to failure indication)	Please inform the Dometic Customer Services

Please visit www.dometicapproved.co.uk or telephone +44 (0) 844 626 0130 to locate your local service centre. Installation may only be carried out by authorised personnel. We recommend contacting your Dometic Service Centre.

DOMETIC REFRIGERATOR MODEL RMD8551

The control panel buttons are not accessible when the refrigerator door is closed. Open the bottom door to reach the operating buttons.



Depending on the door opening direction, there are two LEDs on the left or right edge of the control panel. The outer LED 1 indicates that the refrigerator is operational (blue). The other LED 2 lights red in the event of a fault.

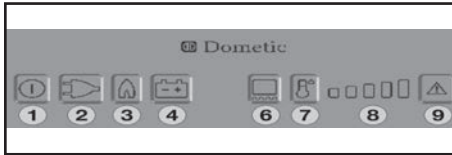

1. Power on-off switch
2. Energy selector 230v AC
3. Energy selector GAS
4. Energy selector 12v DC
5. Spare
6. on/off frame heating
7. Temperature level selection
8. Temperature level display
9. Indicator LED failure/Reset button
GAS FAILURE

SWITCHING ON/OFF

- Switch ON by pressing button 1 for 2 seconds
- Switch OFF by pressing button 1 for 2 seconds

12V DC OPERATION (VEHICLE'S BATTERY)

- Select "Battery voltage" by pressing button 4
- Set temperature by pressing button 7

GAS OPERATION

- Select "Gas" by pressing button 3
- Set temperature by pressing button 7

12V DC OPERATION (VEHICLE'S BATTERY)

- Select "Battery voltage" by pressing button 4
- Set temperature by pressing button 7

SETTING OF THE COOLING COMPARTMENT

TEMPERATURE

- Select the desired cooling compartment temperature by pressing button (7) .
- The LED display (8) of the selected temperature setting is illuminated.
- The scale starts with MIN position at the left.

LED position (small bar = highest temperature) and climbs up to MAX position at the right LED position (large bar = lowest temperature).



The temperature levels do not relate to absolute temperature values.

The cooling unit's performance is influenced by ambient temperatures. Please select the medium setting for ambient temperatures between +15°C and +25°C. The unit operates within its optimum performance range. Dometic refrigerators work according to the absorption principle. For physical reasons, an absorption system responds slowly to changes made by the thermostat controller, by loss of cooling energy through opening the door or during storing food. The devices meet the cooling performance requirements of the Climatic Class SN acc. To EN/ISO 7371 in the temperature range of +10°C to 32°C ambient temperature.

For temperatures below +10°C, winter covers should be installed. For ambient temperatures exceeding +32°C for a longer period of time, it is recommended installing Dometic additional fan (item no. 241 2985 00).

ADDITIONAL FEATURES

- The brightness of the display reduces after a few seconds if no other buttons are pressed. The indicator lights again if a button is pressed. Press the button again to activate the required function.
- Failures are indicated by flashing of the failure indicator LED.
- Should the door be kept open for too long (more than 2 minutes), an acoustic signal is initiated (pulsing whistle tone).
- Should the electronic control detect any failure, an acoustic signal will sound (pulsing whistle tone). At the same time the display starts flashing.

FRAME HEATING

All models are equipped with a frame heating (12vDC/3.5w) around the freezer compartment. During summer months with high temperatures and humidity the metal frame may have water droplets forming. To evaporate these droplets switch on the frame heating with button 6.

Operation with gas mode or 12v mode:

The operating time of the frame heater can be set to 2 hours, 5 hours or continuous operation. After selecting the operating time using the button 6, the temperature level indicator 8 is extinguished for a short time to show the set operating time for a few seconds. The display then returns to the temperature level indicator.

To select operating time press button 6:

Press once for 2 hours

Press twice for 5 hours

Press thrice for permanent operation



In 230v mode the frame heater is continuously on. There is no indication on the control panel.

TROUBLESHOOTING

Display :		Failure :
MES	AES	
LED is flashing	"230" is flashing	230V mode: "230V" not available or voltage too low
LED is flashing	"12" is flashing	12V mode: "12V" not available or voltage too low
LED is flashing	"GAS" is flashing	GAS/Auto mode: Flame not ignited
All temperature setting LEDs are flashing	All temperature setting LEDs are flashing	Temperature sensor defective, refrigerator works on mid temperature setting
LED + all temperature setting LEDs are flashing	"HE1" is flashing	230V - Heating element defective
LED + all temperature setting LEDs are flashing	"HE2" is flashing	12V - Heating element defective

STAINLESS STEEL SINK

Stainless steel sinks need little maintenance other than cleaning immediately after use.

Most deposits can be removed by washing with soap or mild detergent and hot water, followed by a clean water rinse and drying with a soft cloth to prevent water spotting.

For more tenacious deposits a non-abrasive multi-purpose cream cleaner such as CIF should be used, followed by a clean water rinse and drying.

Tannin stains can be removed by a solution of washing soda and water applied with a soft cloth/sponge followed by a clean water rinse to remove any residues, and drying with a soft cloth.

When cleaning with anything other than water be careful not to get the solution onto your kitchen worktop.

Always avoid bleach and trigger-dispense products and never use wire wool or leave wet cloths, pads or containers on the surface as they may form water marks.

TOILET COMPARTMENT SINK

OPAQUE FINISH

For the usual daily cleaning of the opaque sink, use a scrub sponge such as Scotch-Brite with a powder abrasive detergent (for example, scouring powder).

1. Rinse with water.
2. Use a microfibre cloth to wipe.

GLOSSY FINISH

For the usual daily cleaning of the glossy sink, use a damp cloth or sponge with liquid soap, which does not contain abrasive particles.

1. Rinse with water.
2. Use a microfibre cloth to wipe.



Do not use abrasive detergents, alcohol, acetone or solvents, because they will damage the material. In case of accidental contact with such solvents, quickly rinse with water.

SMOKE ALARM

The smoke alarm is operational once the battery is connected. When products of combustion are sensed, the unit sounds an alarm until the air is cleared.

FEATURES

- Battery operated.
- The operating light (red LED) flashes every 40 seconds confirming that the unit is powered.
- Low battery warning: the unit will emit an audible "chirp" once every 40 seconds for 7 days before the battery needs to be replaced. Failure to replace the battery will result in insufficient power to alert you in a real fire situation.
- Sensitivity test button. This tests the sensitivity, circuitry, battery and horn.
- Loud alarm



Test smoke operation after vehicle has been in storage, before each trip and at least once a week during use.

Your alarm requires one 9 volt battery. Under normal use, the battery should last one year.

SIMPLE MAINTENANCE

Clean your smoke alarm once every three months to help keep the unit working correctly. Gently vacuum using a soft brush attachment.

Problems are indicated by two events: The alarm does not sound upon pressing the test button. The operating light remains steadily on or off (i.e. does not flash every 40 seconds, when the unit is not sounding).

Try the following:

- Inspect for obvious damage.
- Check that the unit contains recommended battery type.
- Check that the battery cover has been removed.
- Check that the battery is properly connected.
- Gently vacuum as recommended above.
- Replace battery.

If these procedures do not correct the problem, do NOT attempt repairs; replace the alarm.

PROUD GRAPHIC & EMBLEM SUPPLIER TO Bailey of Bristol Caravans & Motorhomes



We are CGI - a global branding solutions innovator providing design, production and installation services to the caravan, automotive, aerospace, and retail industries.

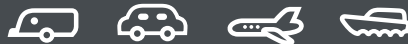

BRAND ENGINEERS

TRUMA MONOCONTROL REGULATOR

INTENDED USE

MonoControl CS is a safety gas pressure regulator for caravans and motorhomes. The gas pressure regulator ensures a uniform output pressure of 30 mbar with a permissible inlet pressure range of 0.3 - 16 bar. The integrated crash sensor (CS) interrupts the flow of gas in the event of an accident with directly acting deceleration of $4.0\text{ g} \pm 1.0\text{ g}$.

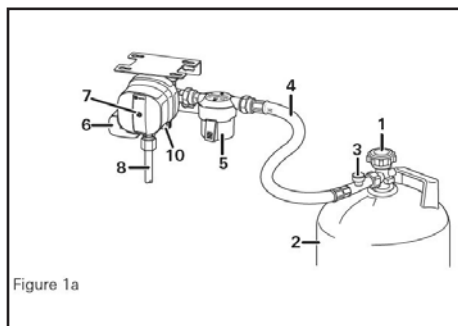

Figure 1a

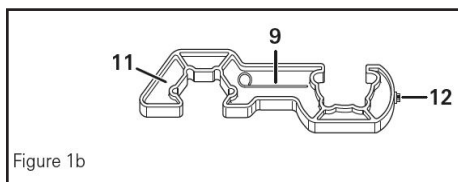

Figure 1b

- 1 = Cylinder valve
- 2 = Gas cylinder
- 3 = Hose rupture protection (HRP)
- 4 = High-pressure hose
- 5 = Gas filter
- 6 = MonoControl CS
- 7 = Yellow reset button of the crash sensor
- 8 = Steel / copper tube
- 9 = Triggering element for the crash sensor
- 10 = Screw cap (test connection)
- 11 = Screw aid a/f 23 / KF
- 12 = Torx T20 (on the screw aid)

START UP

- Open the gas remote switch if present.
- Connect the gas cylinder (2) and ensure that the hose connection is in perfect condition.
- Open the cylinder valve (1).
- Firmly press the hose rupture protection (figure 1a, 3) on the high-pressure hose for about 5 seconds.

- If the yellow reset button (7) is not pressed ("not ready for operation" position), reset the crash sensor.

CRASH SENSOR

The crash sensor has a reset button, the position of which indicates its status: "Ready for operation" position (Figure 2a) or "not ready for operation" position (Figure 2b).

TO RESET

To reset, press the yellow reset button (7) firmly, turn it slightly clockwise, hold it for 5 seconds and ensure that it stays in the "ready for operation" position (Figure 2a). If the reset is not successful, use the Torx T20 (12) on the screw aid (11) to support the clockwise rotation.

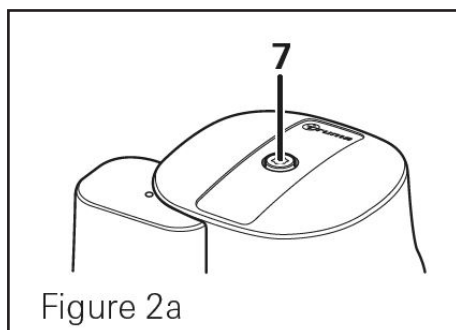

Figure 2a

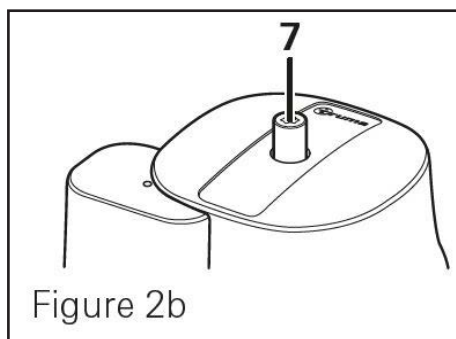

Figure 2b

SOFT FURNISHINGS

CARPET

When cleaning the interior of your caravan please remove the carpet from the vehicle. Vacuum the carpets to take the dirt out of the pile.

For general cleaning use a dry shampoo, following the product's directions.



Never put the carpet in a washing machine or a tumble dryer.

UPHOLSTERY CLEANING AND CARE

Remove dust on a regular basis with your vacuum's upholstery or drape attachment. Try to avoid brushing fabric covers because that can damage the pile.

If you spill something on your upholstery, blot up the excess immediately. Avoid detergents which may damage the fabric's protection. Use a sponge or a clean white cloth but do not wash or rub the fabric. Leave to dry in normal conditions. These actions will not affect the Fire Retardant treatment of the fabric.



Heavy soiling will require professional cleaning.

All fabrics will fade to some degree if exposed to direct sunlight, particularly natural fibres such as cotton etc.

WINTERISATION AND STORAGE

Mattresses are made from fire retardant fabric and are of a honeycomb construction based on solid foam with diamond cut out to perform like a spring. It is recommended that mattresses be stored on edge during winter. Try to keep your cushions away from direct sunlight.

CURTAINS

It is recommended that the curtains in your caravan are washed on a delicate cycle at 30°C. This will not damage the clip glides. Shrinkage may be caused should you decide to dry clean your curtains.

Curtains should not be left closed during daytime hours otherwise some fading may occur.

REMIS BLINDS

REMBASE PLUS WINDOW BLINDS

Please note the blinds should not be closed (down position) when the vehicle is travelling or when in storage for prolonged periods.

The sun screen is housed at the bottom and the fly screen at the top of the blind. To open hold the cross bar and pull up or down. Both blinds can be fully extended to totally cover the window or can meet at any position to give sun shading/privacy and protection from insects entering the vehicle.

The blinds are pre-set to the correct tension. If re-tensioning is required please follow these steps:

- The blind needs to be taken down from the wall by unscrewing the 4 corner screws.
- Lay the blind face down on a table with the cross bars of both blinds meeting in the middle.
- The black cords re-tension the fly screen and the white cords re-tension the sun screen.
- The cords are fixed at either side with a screw. Loosen this screw and gently pull the cord 5mm tighter and repeat on the other side ensuring the cross bar is level.
- Test the tension. This process can be repeated if necessary.

CLEANING

The plastic profiles can be cleaned with a non-abrasive cleaner and damp soft cloth. The blinds should only be dusted lightly with a soft cloth.

REMI FLAIR**FUNCTION**

Both the sun screen and the fly screen are stored at the top. The sun screen can be pulled down and fixed at any of the stops in the side supports. The fly screen can be pulled down and fixed at the bottom of the side supports. When released from the fixing points the blinds will automatically retract.

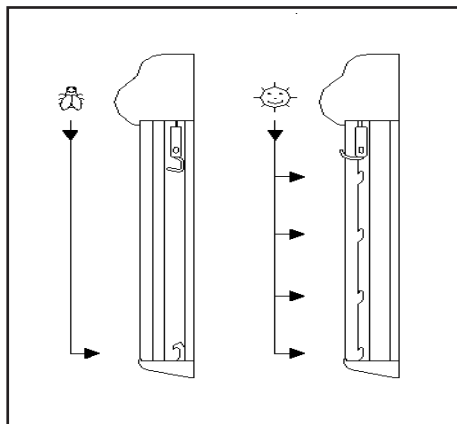

Do not allow the blinds to retract too quickly. Uncontrolled retractions will lead to damage

**MAINTENANCE**

The sun screen can be wiped with a non-abrasive cleaner as can the cassette holder. The fly screen can be cleaned with a soft brush.

Neither blind should be closed (in the down position) when the vehicle is being towed or in storage for prolonged periods.

RE-TENSIONING

If this is required on either blind the screw head located on the side of the roller should be turned once and the blind tested. If the tension is still not correct further turns may be required.

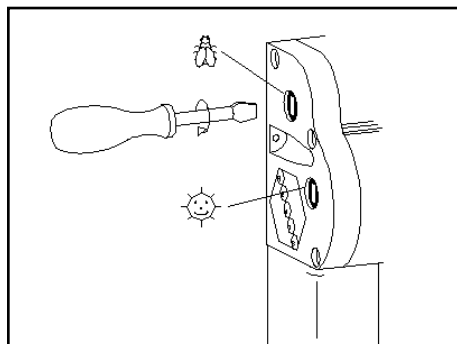

GENERAL CARE AND MAINTENANCE OF YOUR CARAVAN

EXTERIOR

The exterior of your caravan is very durable and easy to clean owing to its high gloss properties. To maintain a showroom finish, you will need to wash the caravan and its parts frequently, using a suitable cleaner. Avoid using strong alkaline (e.g. tri-sodium phosphate) or acidic cleaners or abrasives.

Waxing the components once or twice a year with a good grade paste wax will help to maintain the colour and finish.

CLEANING/USAGE INFORMATION

- Wash the caravan by hand, using a sponge and plenty of cleaning solution to avoid scratching.
- Always rinse away any suds/cleaner from your caravan.
- Dry the vehicle with a chamois or microfibre cloth.
- It is imperative to ensure that the area surrounding the rooflight is completely dried. This will avoid both condensation and damp collecting around said roof light.
- Where possible position the vehicle nose down for a short period to avoid water pooling and collecting on the roof area.
- Do not apply a carnauba-based wax to the vehicle.
- Do not use a mechanical brush washing system such as a car wash.
- Never pressure wash your vehicle.
- Do not use solvents.
- Do not use acrylic cleaners.



Under no circumstances should you use any abrasive agents, methylated spirit, white spirit or other solvents to the exterior of your caravan.

- No touch up painting should be carried out prior to consulting a Bailey Service Centre for approved methods.
- All items stored in the gas bottle storage locker must be secured to prevent impact damage to the inside of the body panel when the caravan is being towed.
- Do not allow any chemicals to spill or leak

into the gas box floor. Before placing items in the cradle ensure that the tray is clean and free from any debris. Cleaning should only be carried out with warm soapy water.



The use of high pressure water jets to clean your caravan will invalidate your warranty.

ACRYLIC WINDOWS

The windows fitted to your Bailey caravan are manufactured from high quality acrylic using the latest plastic processing methods.

For cleaning, use generous amounts of water to wash away dust and road grit etc. Then use a soft cloth and warm soapy water and gently remove the remaining dirt. Avoid abrasive cleaning materials and detergents.

As with all plastic materials, acrylic should not be allowed to come into contact with chemicals such as paint remover, fly spray, acetone, dishwasher detergent and car cleaning detergent.



Never polish with a dry cloth. During high sun do not close the window blinds completely and open the windows into the ventilation position. While the caravan is in motion please ensure that the windows are fully closed.

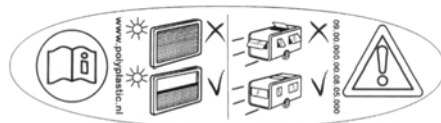

Dependent upon the temperature inside the caravan compared to outside, condensation may be experienced between the window panes. This is a perfectly normal occurrence as the windows are not sealed units. To disperse condensation, remove the bungs using a pair of blunt end tweezers in the corners of the window unit (preferably on a warm day) until the condensation disperses and then replace the bungs.

WINDOW CATCHES AND STAYS

OPENING

- Turn catch arm to the vertical position to open.
- A night vent position is available by depressing the locking knob and locating the catch into the middle catch plate slot.
- The windows are held open by an adjustable arm. Tightening the knob in a clockwise direction will hold the window open in the desired position.



Always ensure the knob is unscrewed before closing the window. Failure to do so may cause damage to the window stay arm. Always ensure that windows are fully closed during wet weather and not on night vent settings.

HUMIDITY

Air contains moisture.

The higher the temperature of the air the more water it is able to hold. Air at 20°C can hold a lot more moisture than air at 10°C. The term “relative humidity” describes the amount moisture air contains at a given temperature. 100% relative humidity means the air is holding as much moisture as possible at the current temperature.

The more humid the air in your caravan, the more energy it takes to heat because the water in the air is also being heated.

A good range of indoor humidity for comfort and health is between 30% and 60% during cooler months of the year. Mould is likely to occur if the relative humidity indoors is 70% or more for long periods of time. Keeping humidity levels under 50% also helps to minimise or control dust mites.

CONDENSATION

Water vapour condenses on cold surfaces when the humidity is high inside the van but it is cold outside.

Possible causes of condensation

- Lack of adequate heating or ventilation.
- Water ingress from the outside through leakage, seepage or open windows.
- High levels of moisture/water vapour being produced inside the caravan.

Humid air and condensation can also be generated by things people do on a daily basis.

- Cooking: up to 3 litres per day.
- Showers: 1.5 litres per person.
- Washing dishes: up to 1 litres per day.
- Breathing: active adult 0.2 litres an hour.
- Breathing, adult asleep: 0.02 litres an hour.

HOW TO KEEP YOUR CARAVAN DRY AND AVOID CONDENSATION

There are lots of things you can do to minimise dampness and condensation in your caravan.

The key actions:

- Provide ventilation and/or reduce relative humidity of air, particularly in moisture prone periods of year.
- When the moisture is produced in the van (cooking, shower).
- Increase heating to raise the temperature of the air and the cold surfaces.
- On dry days open windows to allow humid air to ventilate out of the van. It is better to open a few windows a little throughout the whole caravan. This helps the air to move through the caravan.
- One window open wide may not be as effective.
- Try to do this as often as possible (at least once a week), but keep windows closed on wet days as damp air may increase indoor humidity.

FURNITURE

Moisture in the air can cause damage to furniture as the wood expands or contracts with an increase or decrease in the relative humidity. A relative humidity of between 40% and 60% is tolerable. If values are maintained outside this range for a sustained period damage to the furniture may occur. The damage can be visible if the relative humidity is higher than 80% for a long time. To prevent damage, ventilate the van, using dehumidifiers or water absorbent substances.

When wood is wet, wipe it dry. Do not just wait for the sun to dry it. The longer the water stays on the surface, the more damage it can do. Defects caused by high temperature or high relative humidity of air will not be covered by your warranty.

WINTERIZATION & STORAGE

The following applies whenever your caravan is stored, particularly during winter months. If you do not intend on using your vehicle for a while it is an ideal time to arrange for your caravan to have its annual service at your appointed dealer.

- It is a good idea to store the caravan with the nose down; this will avoid any water pooling on the roof.
- Do not leave your vehicle near trees or latch-type gates due to possible wind damage.
- Keep any grass around the floor of the caravan short to maintain airflow and stop any possible damp getting into it.
- It is advised that the caravan is ventilated regularly throughout the storage period, opening windows, doors and rooflights where possible.
- All moving parts should be checked for free operation.
- Clean all cooking appliances and the refrigerator before parking up the vehicle.
- Charge up the on-board battery every 2 months.
- Leave the refrigerator door open.
- Leave the furniture and locker doors open to allow air to circulate fully.
- Ensure that the entire water system is thoroughly drained.
- Make sure that all plumbing pipes, drains, and water supply appliances within the caravan are properly drained.
- Remove the battery from the caravan to keep it warmer. If the battery cells were to freeze this could cause damage to the cells and decrease the life of the battery.
- Try to cover as much as possible of the underside of the caravan to prevent snow from collecting. This will help to prevent damage to the tyres due to weather conditions.
- Apply a lubricant to all locks; this will prevent freezing.

MODIFICATIONS & DIY WORK

Owners need to be aware that carrying out DIY modifications to your caravan may, in certain circumstances, invalidate the warranty cover and could also affect the safety and structure of the vehicle.

CARAVAN KEYS

Each caravan is supplied with 2 identical keys. In the event of both keys being lost these cannot be replaced. In this instance a new lock will have to be fitted with a fresh set of keys.

SPARES & AFTERSALES

There are numerous parts and accessories available for your caravan either from your Bailey retailer or through the Bailey Parts website. You are more than welcome to contact the parts website for anything you may require. However, if it is a safety or warranty-critical item you will need to obtain it from your Bailey retailer who will fit the component for you.

www.primaleisure.com

FRONT BED MAKE UP

BED MAKE UP

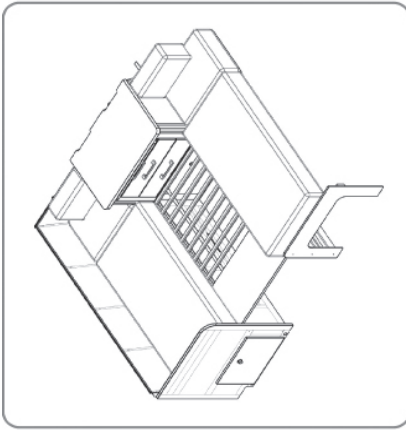

1 The lounge is shown in the day setting.

1

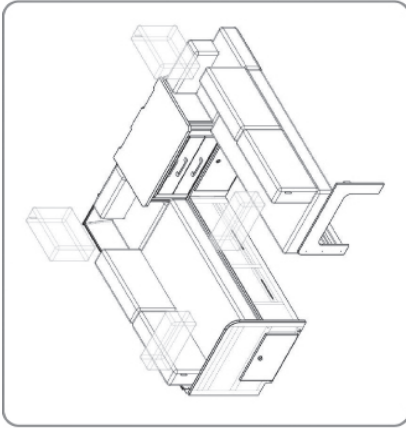

2 To change to night setting, firstly remove the four backrest cushions that are not needed.

2

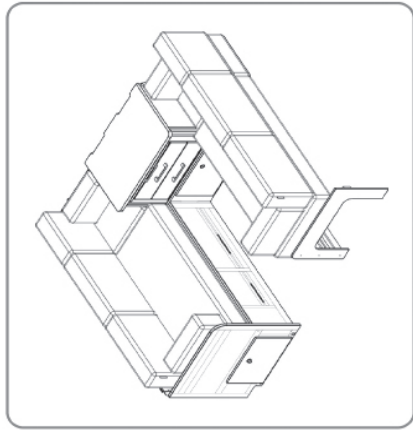

3 Pull out the leader board.

3

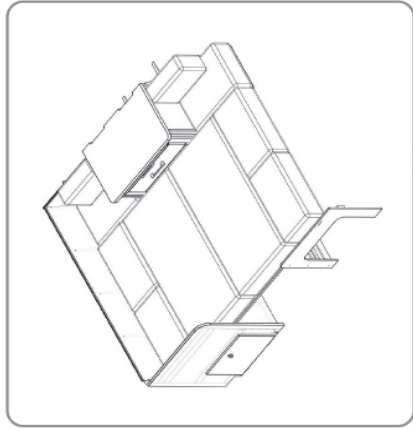

5 Turn over the seat bases and place on top of the leader board.

5

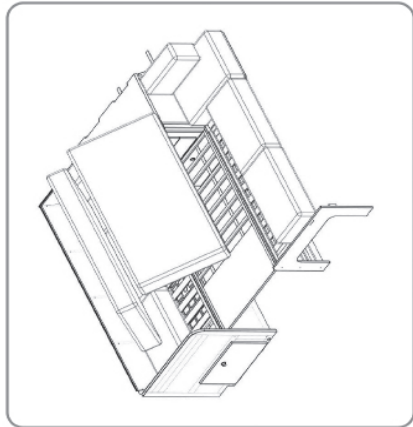

4 Place the back rests flat and press them up flush against the baffleboards.

4

6 Reverse the process to return the lounge to its day setting.

6

REAR FIXED BED EXTENSION

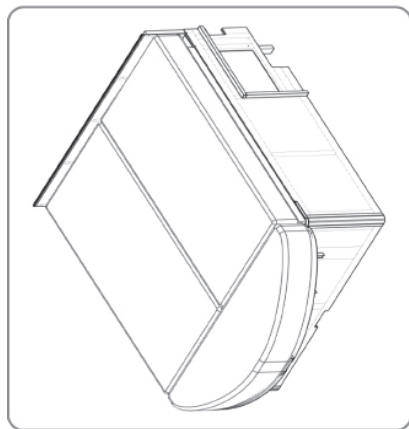

1

The bed is shown in the fully extended position.

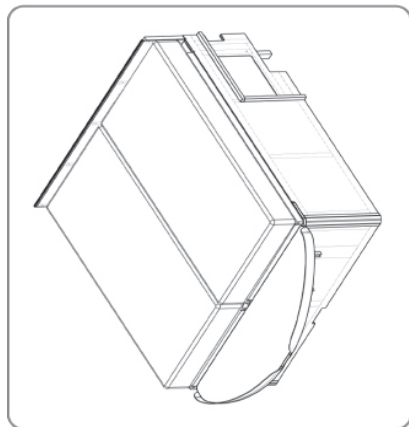

2

To shorten the length of the bed, firstly remove the bottom section of the mattress.

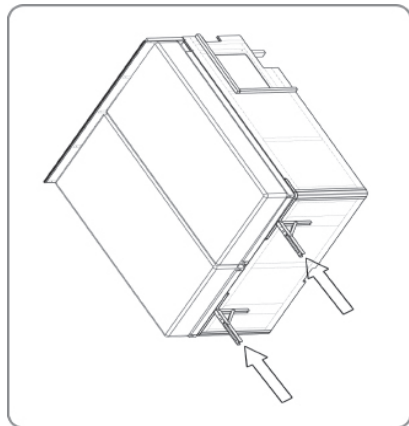

3

Beneath the shelf you will find two hinges (Note the shelf has been faded out for illustration purposes).

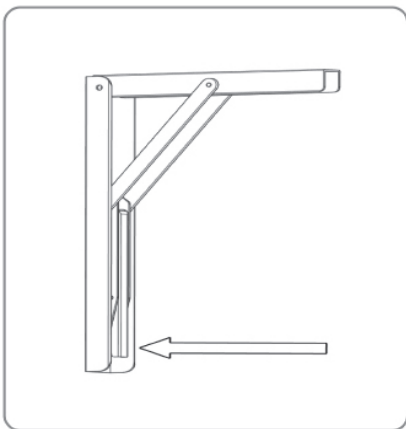

4

The hinges are collapsed by lifting the release bars upwards. This will release the hinge and allow the panel to drop.

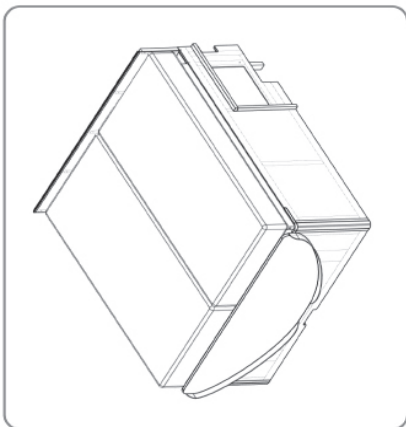

5

When both hinges have collapsed the lip folds down and the bed is shortened.

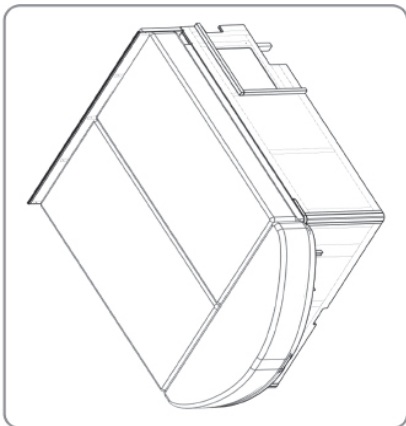

6

Reverse the process to return the bed to its lengthened state.

REAR DINETTE BED MAKE UP

BED MAKE UP

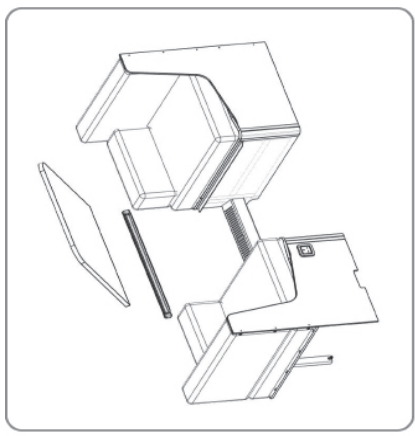

1

The Dinette is shown in the day setting.

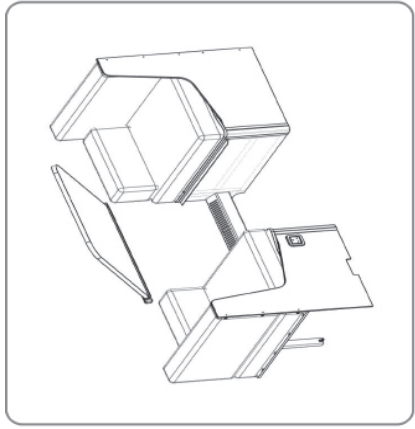

2

To change to night setting. Firstly lift up the table top.

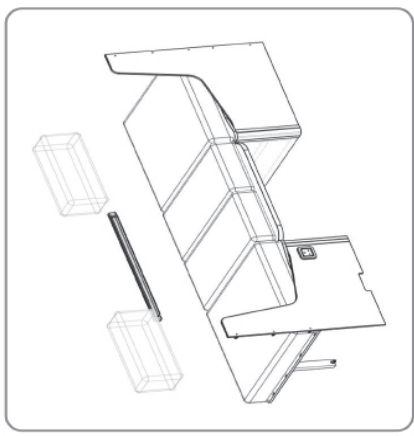

3

Remove the table top from the hinge.

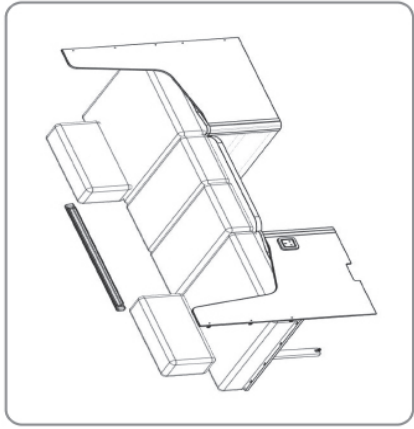

4

Place the table top on the plastic runners at the edge of the seat base.

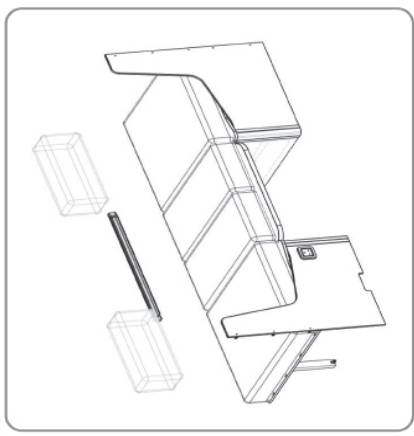

5

Place the two seat backs over the table top.

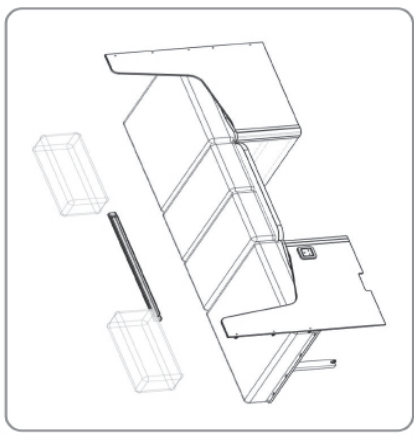

6

Remove the remaining two back rests to obtain the full width.

GRANDE DINETTE BED MAKE UP

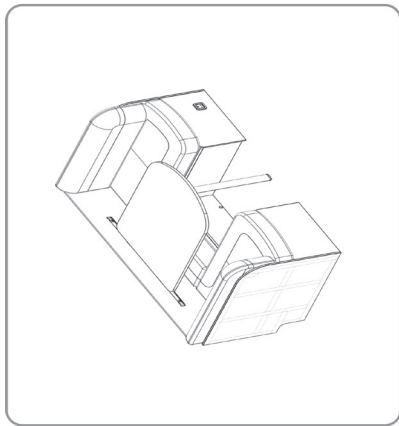

1

The lounge is shown in the day setting.

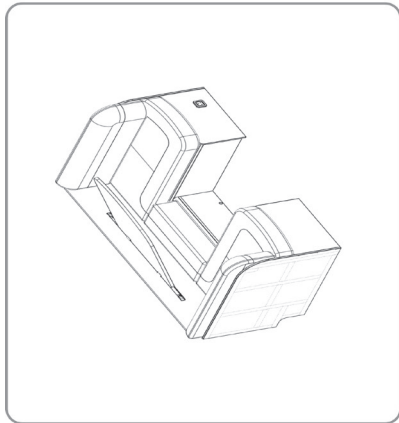

2

To change to night setting, firstly remove the table from the side wall and bend the leg into the storage position.

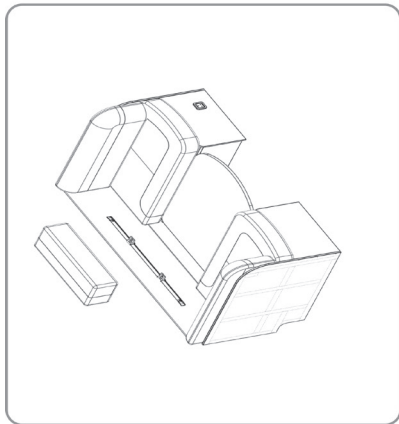

3

Remove and store the infill cushion and place the table flat on the plastic runners.

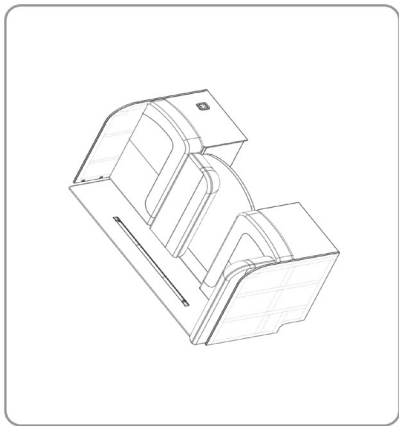

4

Place the back rest face down on top of the table.

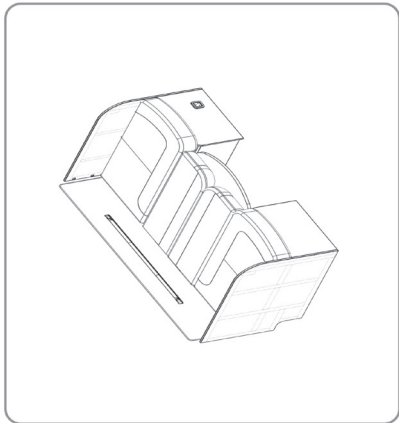

5

Repeat the previous process with the other back rest.

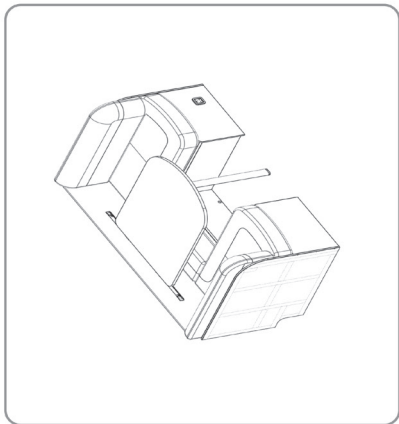

6

Reverse the process to return the lounge to its day setting.

BED MAKE UP

RETRACTABLE REAR BED

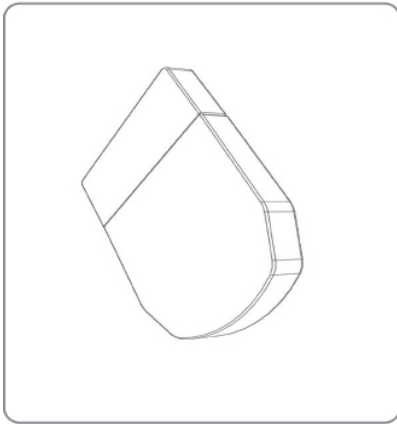

1 The rear fixed bed in certain models is retractable.

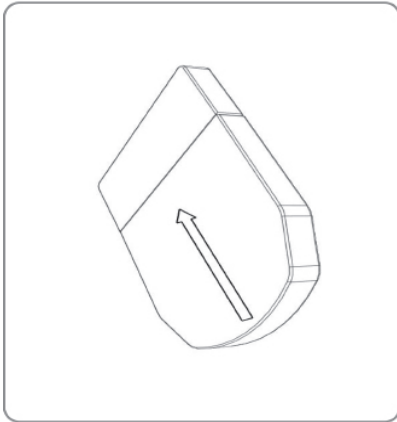

2 To retract the bed, lift the foot of the bed up and then push towards the head.

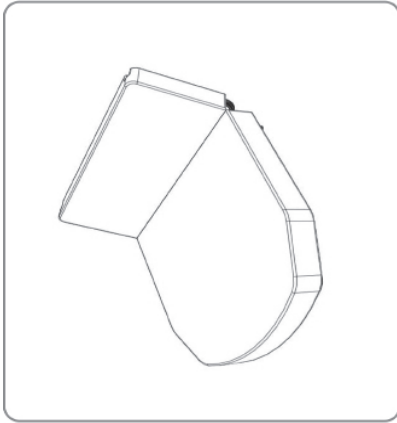

3 The locking system below the bed frame will lock into place in various positions. Above is the retracted position.

ADDITIONAL FOLD OUT REAR BED



1 The additional bunk should be pulled from the bottom away from the side wall.

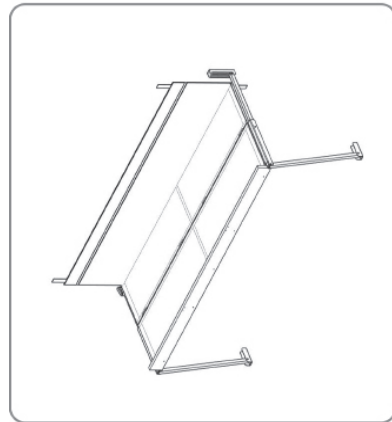

2 The bunk will rotate and open out to form the bed. Ensure you lock the bed in position.

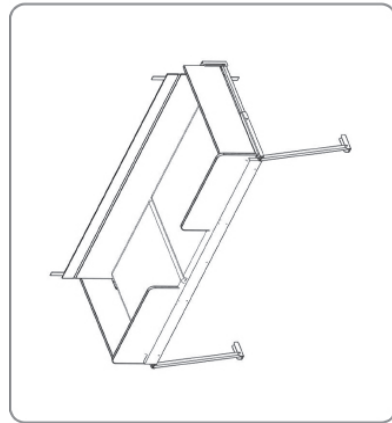

3 Once open position the mattress/cushions and secure the fall out panels in their correct position.

FREE STANDING TABLE

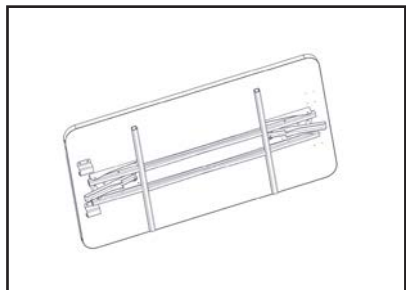

Dependant upon caravan model you may have been supplied a free standing table.

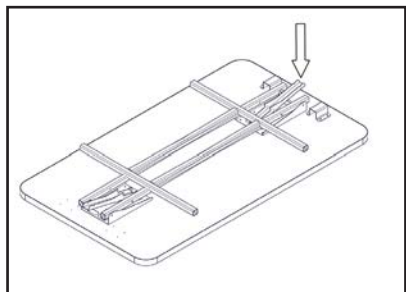

1. The table should be laid upside down on a flat surface. You should then depress the leg retaining lever. This will release the leg.

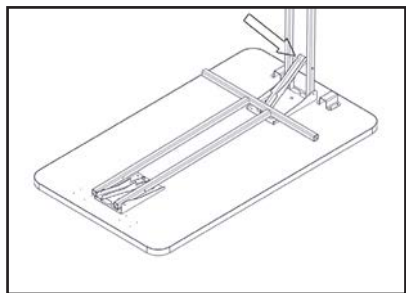

2. Raise the leg to its vertical position until the securing bar locks in place.

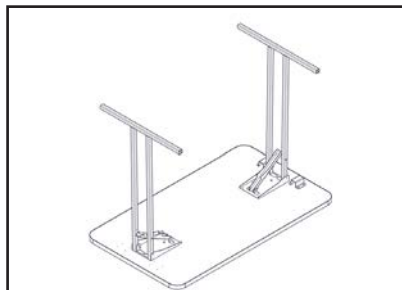

3.Repeat the process with the other leg.



Always erect the table upside down due to a finger trap hazard being present at the base of the hinge/leg (Fig 1/2). When erected the right way up the weight of the legs will cause them to fall into place. This action poses a finger trap hazard in and around the hinge.

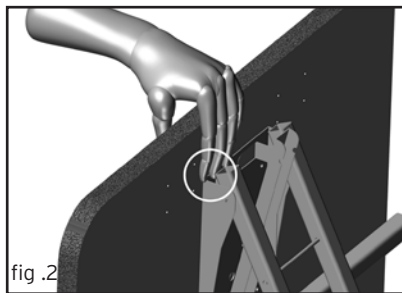

©Bailey of Bristol 2018. All rights reserved

No part of this document may be reproduced or transmitted in any form or by any means, electronic or mechanical, for any purpose, without the express permission of Bailey of Bristol Ltd.

Bailey Owners Club

Nearly 50 years ago, Bailey Owners Club was built on a foundation of friendship, fun and freedom. The Club is run by and for members and is dedicated to the hobby of rallying with Bailey caravans and motorhomes.

Rallies are held across the UK, with a diverse range of activities suitable for all ages. Biennially Bailey open the factory exclusively for Bailey Owners Club members.

The Club fundraises for a range of charities throughout the year.

It couldn't be easier to join - simply go to www.baileyownersclub.org for details on how to become a member.



Scheduled Service Type	Service Agent	Retailer Stamp	Technician's Name	Date
Retailer Pre-Delivery Inspection				
1st Year Service (necessary to ensure warranty cover in the second year)				
2nd Year Service (necessary to ensure warranty cover in the third year)				
3rd Year Service (necessary to ensure warranty cover in the fourth year)				
4th Year Service (necessary to ensure warranty cover in the fifth year)				

5th Year Service (necessary to ensure warranty cover in the sixth year)				
6th Year Service (necessary to ensure warranty cover in the seventh year)				
7th Year Service (necessary to ensure warranty cover in the eighth year)				
8th Year Service (necessary to ensure warranty cover in the ninth year.)				
9th Year Service (necessary to ensure warranty cover in the tenth year)				
10th Year Service				

11th Year Service				
12th Year Service				
13th Year Service				
14th Year Service				
15th Year Service				



From the 2011 season the method of calculating the Mass in Running Order (MRO) and user payload figures has changed in order to bring it in line with European Vehicle Directives. Although the method of calculation has changed, the overall effect is that the amount of payload available to the customer has remained the same.

The following Items are included in the MRO:

LPG - The mass of the recommended gas storage tank(s) when filled to 100% of the permissible maximum capacity. A mass of 10 kg per cylinder is assumed and the number of cylinders is equal to the number of connections provided at the regulator.

Fluids - The mass of the liquids normally remaining in the systems:

Water heater system = 100% of the manufacturer stated travelling capacity **(Bailey state 0%)**

Central heating system = 100% of the mass of fluid in the system

Freshwater = 100% of the manufacturer stated travelling capacity (you must travel with all water tanks empty) **(Bailey state 0%)**

Waste water holding tank = Empty

Toilet system flushing tank = 100% of the manufacturer stated travelling capacity **(Bailey state 0%)**

Toilet system holding tank = Empty

Essential fluids for the use of any other items of standard or factory fitted optional equipment = 100% of the manufacturer stated travelling capacity **(Bailey state 0%)**

Pitch Lead = 4Kg for the low voltage connection cable

Part of the MRO can be utilised as additional payload if you wish to travel without any of the above. The saved weight will = additional payload.



Your caravan should be fully drained down prior to being in transit. All fluid levels should be at 0% (excluding Glycol heating fluid contained within wet heating systems). The fluid travelling capacity of Bailey caravans is 0%. Any fluids contained within the caravan during transit should be deducted from your payload.

Typical masses consist of:

Kettle	0,5Kg	Aquaroll (empty)	5Kg
Bed Linen	6Kg	Waste Bin	1Kg
Crockery	5Kg	Toilet Fluid	2,5 Kg
Saucepans	3Kg	Cutlery	2 Kg
Wastemaster	6Kg	Battery	25 Kg



All dimensions are approximate due to slight variations in suspension heights, loading conditions and tyre pressures. Customers should verify the actual dimensions of their touring caravan before committing to anything that could be impacted by these dimensions. Any Retailer fit options will reduce the overall payload available to the user of the caravan. If you require additional payload it is possible to upgrade the MTPLM on some vehicles. Please contact your Bailey Caravan Retailer for more information. Awning sizes are ground to ground dimensions through the awning channel. Dimensions are issued as a guideline only.

Unicorn IV/Black	Seville	Vigo	Valencia	Cadiz	Madrid	Cabrera	Cartagena	Pamplona	Barcelona	Segovia	Merida
Berths	2	4	4	4	3	4	4	4	4	5	2
Axles	1	1	1	1	1	1	2	2	2	2	1
Shipping Length	6190mm	7358mm	7358mm	7385mm	7358mm*	7358mm	7908mm	7908mm	7908mm	7908mm	6189mm
Internal Length	4665mm	5829mm	5829mm	5829mm	5829mm*	5829mm	6379mm	6379mm	6379mm	6379mm	4812mm
Overall Width	2280mm	2280mm	2280mm	2280mm	2280mm	2280mm	2280mm	2280mm	2280mm	2280mm	2280mm
Overall Height (including aerial)	2610mm	2610mm	2610mm	2610mm	2610mm	2610mm	2610mm	2610mm	2610mm	2610mm	2610mm
Maximum Headroom	1960mm	1960mm	1960mm	1960mm	1960mm	1960mm	1960mm	1960mm	1960mm	1960mm	1960mm
Body Length (excluding hitch)	5290mm	6500mm	6500mm	6500mm	6500mm	6500mm	7049mm	7049mm	7049mm	7049mm	5323mm
Tyre Sizes	185R14	185R14	185R14	185R14	185R14	185R14	185/65R14	185/65R14	185/65R14	185/65R14	185R14
Awning Dimension	9150mm	10270mm	10270mm	10270mm	10270mm	10270mm	10820mm	10820mm	10820mm	10820mm	9168mm
Tyre Pressure	60psi	60psi	60psi	60psi	60psi	60psi	35psi	35psi	35psi	35psi	60psi
MRO	1203kg	1344kg	1344kg	1335kg	1311kg	1377kg	1522kg	1538kg	1520kg	1587kg	1217kg
MTPLM	1326kg	1499kg	1499kg	1490kg	1453kg	1532kg	1682kg	1698kg	1680kg	1767kg	1330kg
Opt Equipment Payload	0kg	0kg	0kg	0kg	0kg	0kg	0kg	0kg	0kg	0kg	0kg
Total User Payload	123kg	155kg	155kg	155kg	142kg	155kg	160kg	160kg	160kg	180kg	113kg
Max Static Load on the Coupling Head	100kg	100kg	100kg	100kg	100kg	100kg	100kg	100kg	100kg	100kg	100kg
Wheel Torque	130N	130N	130N	130N	130N	130N	130N	130N	130N	130N	130N
Gas Locker	6kg x2	6kg x2	6kg x2	6kg x2	6kg x2	6kg x2	6kg x2	6kg x2	6kg x2	6kg x2	6kg x2

Pegasus Grande SE	Messina	Bologna	Rimini	Brindisi	Palermo	Turin
Berths	4	4	4	4	6	6
Axles	2	2	1	1	2	2
Shipping Length	7863mm	7863mm	7381mm	7381mm	7863mm	7863mm
Internal Length	6334mm	6334mm	5904mm	5904mm	6334mm	6334mm
Overall Width	2450mm	2450mm	2450mm	2450mm	2450mm	2450mm
Overall Height (including aerial)	2583mm	2583mm	2608mm	2608mm	2583mm	2583mm
Maximum Headroom	1960mm	1960mm	1960mm	1960mm	1960mm	1960mm
Body Length (excluding hitch)	6989mm	6989mm	6496mm	6496mm	6989mm	6989mm
Tyre Sizes	185/65R14	185/65R14	185R14C	185R14C	185/65R14	185/65R14
Awning Dimension	10772mm	10772mm	10332mm	10332mm	10772mm	10772mm
Tyre Pressure	40psi	40psi	60psi	60psi	40psi	40psi
MRO	1525kg	1491kg	1370kg	1360kg	1530kg	1525kg
MTPLM	1685kg	1651kg	1525kg	1515kg	1710kg	1705kg
Opt Equipment Payload	0kg	0kg	0kg	0kg	0kg	0kg
Total User Payload	160kg	160kg	155kg	155kg	180kg	180kg
Max Static Load on the Coupling Head	100kg	100kg	100kg	100kg	100kg	100kg
Wheel Bolt Torque	130nm	130nm	130nm	130nm	130nm	130nm
Gas Locker Capacity	2x6kg	2x6kg	2x6kg	2x6kg	2x6kg	2x6kg

Phoenix +	420	440	640	642	644	650
Berths	2	4	4	4	4	5
Axles	1	1	1	1	1	1
Shipping Length	5564mm	6883mm	7370mm	7370mm	7370mm	7370mm
Internal Length	4032mm	5351mm	5841mm	5841mm	5841mm	5841mm
Overall Width	2212mm	2212mm	2212mm	2212mm	2212mm	2212mm
Overall Height (including aerial)	2624mm	2624mm	2624mm	2624mm	2624mm	2624mm
Maximum Headroom	1960mm	1960mm	1960mm	1960mm	1960mm	1960mm
Body Length (excluding hitch)	4694mm	6013mm	6470mm	6470mm	6470mm	6470mm
Tyre Sizes	185R14C	185R14C	185R14C	185R14C	185R14C	185R14C
Awning Dimension	8571mm	9860mm	10365mm	10364mm	10376mm	10376mm
Tyre Pressure	48psi	60psi	60psi	60psi	60psi	60psi
MRO	1029kg	1197kg	1257kg	1255kg	1240kg	1244kg
MTPLM	1146kg	1347kg	1411kg	1410kg	1395kg	1409kg
Opt Equipment Payload	0	0	0	0	0	0
Total User Payload	117kg	150kg	155kg	155kg	155kg	165kg
Max Static Load on the Coupling Head	100kg	100kg	100kg	100kg	100kg	100kg
Wheel Bolt Torque	130N	130N	130N	130N	130N	130N
Gas Locker Capacity	6kg x2	6kg x2	6kg x2	6kg x2	6kg x2	6kg x2

Alicanto Grande	Estoril	Sintra	Porto	Faro
Berths	4	4	4	4
Axles	1	1	2	2
Shipping Length	7381mm	7381mm	7862mm	7862mm
Internal Length	6112mm	6112mm	6334mm	6334mm
Overall Width	2450mm	2450mm	2450mm	2450mm
Overall Height (including aerial)	2610mm	2610mm	2610mm	2610mm
Maximum Headroom	1960mm	1960mm	1960mm	1960mm
Body Length (excluding hitch)	6496mm	6496mm	9687mm	9687mm
Tyre Sizes	195/70R15	195/70R15	185/65/R15	185/65/R15
Awning Dimension	10310mm	10310mm	10830mm	10830mm
Tyre Pressure	60psi	60psi	40psi	40psi
MRO	1469kg	1441kg	1619kg	1630kg
MTPLM	1624kg	1596kg	1779kg	1790kg
Opt Equipment Payload	0kg	0kg	0kg	0kg
Total User Payload	155kg	155kg	160kg	160kg
Max Static Load on the Coupling Head	120kg	120kg	120kg	120kg
Wheel Torque	130N	130N	130N	130N
Gas Locker	6kg x2	6kg x2	6kg x2	6kg x2

Discovery	D4-2	D4-3	D4-4
Berths	2	4	4
Axles	1	1	1
Shipping Length	5615mm	6112mm	7141mm
Internal Length	3866mm	4354mm	5398mm
Overall Width	2228mm	2228mm	2228mm
Overall Height (including aerial)	2605mm	2605m	2605mm
Maximum Headroom	1960mm	1960mm	1960mm
Body Length (excluding hitch)	4119mm	4620mm	5649mm
Tyre Sizes	185R14	185R14	185R14
Awning Dimension	10042mm	10558mm	11557mm
Tyre Pressure	55psi	55psi	55psi
MRO	884kg	946kg	1059mm
MTPLM	995kg	1082kg	1206kg
Opt Equipment Payload	0	0	0
Total User Payload	111kg	136kg	146kg
Max Static Load on the Coupling Head	100kg	100kg	100kg
Wheel Bolt Torque	130N	130N	130N
Gas Locker Capacity	6kg x2	6kg x2	6kg x2

Unicorn IV/Black	Seville	Vigo	Valencia	Cadiz	Madrid	Cabrera	Cartagena	Pamplona	Barcelona	Seville	Merida
Front Double	4'10"x6'6"	4'1"x6'6"	4'10"x6'6"	4'1"x6'6"	4'1"x6'6"	4'1"x6'6"	4' 10"x6' 6"	4' 10"x6' 6"	4' 10"x6' 6"	4' 10"x6' 6"	6'5" x 4'11"
Front N/S Single	2'2"x6'2"	2'2"x5'7"	2'2"x6'2"	2'2"x5'7"	2'2"x6'2"	2'2"x5'7"	2'2"x6'2"	2'2"x6'2"	2'2"x6'2"	2'2"x6'2"	6'4" x 2'11"
Front O/S Single	2'2"x6'2"	2'2"x5'7"	2'2"x6'2"	2'2"x5'7"	2'2"x6'2"	2'2"x5'7"	2'2"x6'2"	2'2"x6'2"	2'2"x6'2"	2'2"x6'2"	6'4" x 2'11"
Rear Fixed Bed	N/A	4'7"x6'1"	4'3"x6'6"	N/A	N/A	4'7"x6'1"	4'7"x6'1"	4'7"x6'1"	N/A	N/A	N/A
Rear O/S Single	N/A	N/A	N/A	2'2"x6'3"	N/A	N/A	N/A	N/A	N/A	2'3"x6'2"	N/A
Rear N/S Single	N/A	N/A	N/A	2'2"x6'3"	N/A	N/A	N/A	N/A	N/A	N/A	N/A
Side Dinette Bunk	N/A	N/A	N/A	N/A	N/A	N/A	N/A	N/A	N/A	2'3"x6'3"	N/A

Pegasus Grande SE	Messina	Bologna	Rimini	Brindisi	Palermo	Turin
Front Double	7'3" x 4'3"	7'3" x 4'3"	7'3" x 4'0"	7'3" x 4'0"	7'1" x 4'9"	7'1" x 4'9"
Front nearside Single	6'2" x 2'1"	6'2" x 2'1"	N/A	N/A	N/A	N/A
Front Offside Single	5'10" x 2'1"	5'10" x 2'1"	5'8" x 2'1"	5'8" x 2'1"	6'2" x 2'1"	6'2" x 2'1"
Fixed Bed	6'1" x 4'7"	6'3" x 4'7"	N/A	6'3" x 4'7"	N/A	6'1" x 4'6"
Rear Offside Single Upper/Lower	N/A	N/A	6'2" x 2'6"	N/A	N/A	N/A
Rear Nearside Single	N/A	N/A	6'2" x 2'6"	N/A	6'1" x 2'6"	N/A
Middle Dinette	N/A	N/A	N/A	N/A	6'6" x 3'8"	6'6" x 3'8"

Phoenix+	420	440	640	642	644	650
Front Double	6`2" x 4`9"	6`2" x 3`7"	6`2" x 4`7"	6`2" x 4`7"	6`2" x 4`7"	6`2" x 4`7"
Front nearside Single	6`1" x 2`1"	4`11" x 2`1"	5`11" x 2`1"	5`11" x 2`1"	5`11" x 2`1"	5`11" x 2`1"
Front Offside Single	6`1" x 2`1"	4`11" x 2`1"	5`11" x 2`1"	5`11" x 2`1"	5`11" x 2`1"	5`11" x 2`1"
Rear Fixed Bed	N/A	6`3" x 4`4"	6`2" x 4`6"	N/A	6`2" x 4`6"	N/A
Rear Offside Single	N/A	N/A	N/A	6`2" x 2`2"	N/A	N/A
Rear Nearside Single	N/A	N/A	N/A	6`2" x 2`2"	N/A	6`2" x 2`3"
Upper Rear Bunk	N/A	N/A	N/A	N/A	N/A	6`1" x 2`2"
Lower Bunk	N/A	N/A	N/A	N/A	N/A	N/A

Alicanto	Estoril	Sintra	Faro	Porto
Front Double	6`8" x 5`0"	6`12" x 5`0"	6`8" x 4`10"	6`12" x 5`0"
Front nearside Single	6`0" x 2`1"	6`0" x 2`1"	5`11" x 2`1"	6`0" x 2`1"
Front Offside Single	5`11" x 2`1"	5`11" x 2`1"	6`0" x 2`1"	6`2" x 2`1"
Rear Fixed Bed	N/A	6`3" x 4`8"	6`2" x 4`8"	6`3" x 4`8"
Rear Offside Single	6`4" x 2`6"	N/A	N/A	N/A
Rear Nearside Single	6`4" x 2`6"	N/A	N/A	N/A
Upper Rear Bunk	N/A	N/A	N/A	N/A
Lower Bunk	N/A	N/A	N/A	N/A

Discovery	D4-2	D4-3	D4-4
Front Double	6`2" x 5`8"	6`2" x 3`0"	6`2" x 4`6"
Front nearside Single	6`7" x 2`1"	3`11" x 2`1"	5`5" x 2`1"
Front Offside Single	6`7" x 2`1"	4`10" x 2`1"	5`5" x 2`1"
Rear Fixed Bed	N/A	6`6" x 4`0"	6`1" x 4`4"
Rear Offside Single	N/A	N/A	N/A
Rear Nearside Single	N/A	N/A	N/A
Upper Rear Bunk	N/A	N/A	N/A
Lower Bunk	N/A	N/A	N/A

PAGE LEFT BLANK INTENTIONALLY

BAILEY PEGASUS CIRCUIT DIAGRAM

DRAWING TEMPLATE-A C7048
ISSUE 1

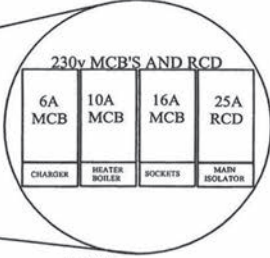
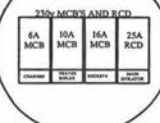
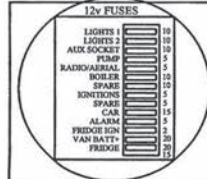
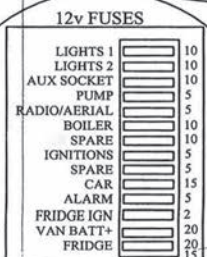
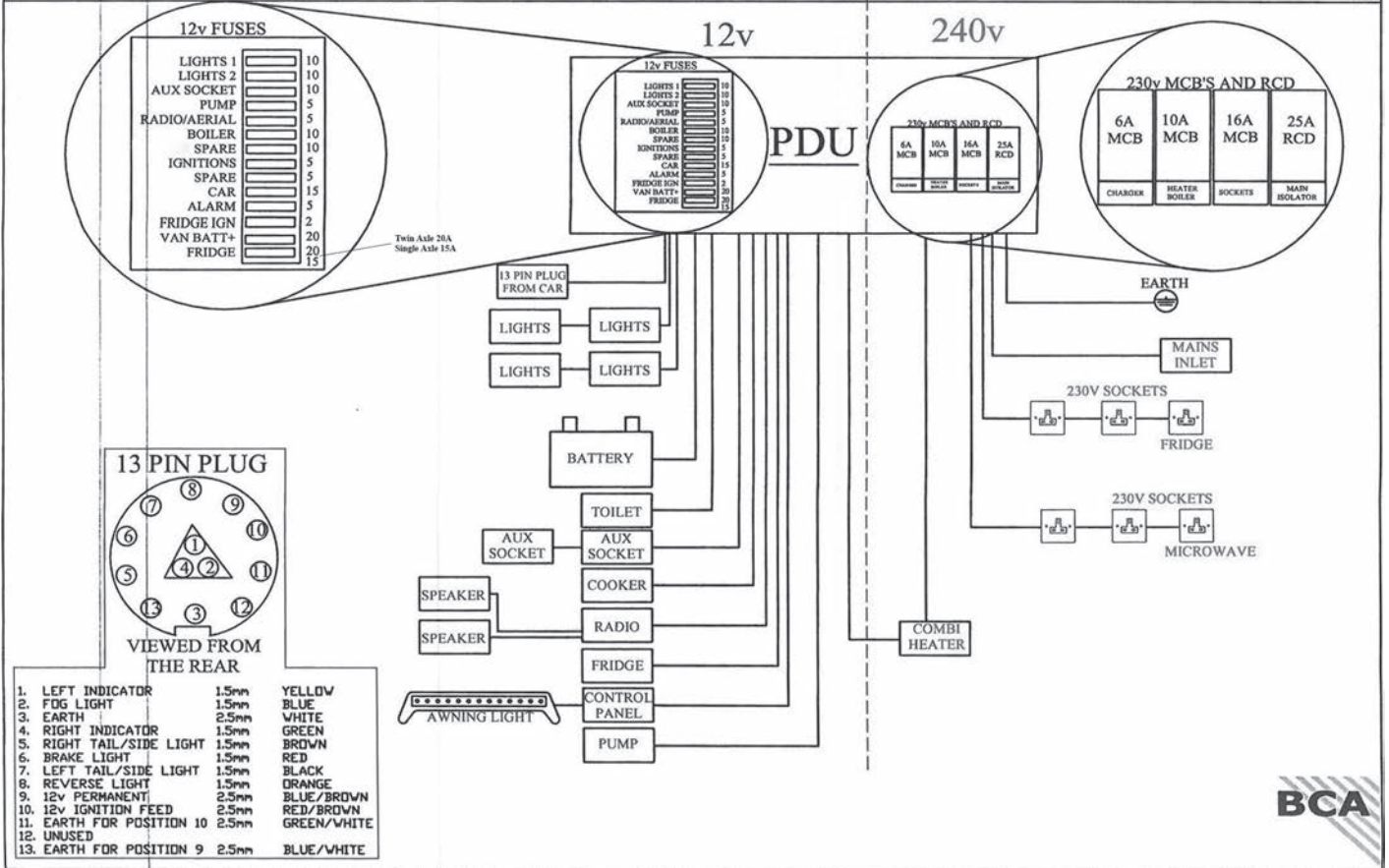

- | | | |
|---------------------------|-------|-------------|
| 1. LEFT INDICATOR | 1.5mm | YELLOW |
| 2. FOG LIGHT | 1.5mm | BLUE |
| 3. EARTH | 2.5mm | WHITE |
| 4. RIGHT INDICATOR | 1.5mm | GREEN |
| 5. RIGHT TAIL/SIDE LIGHT | 1.5mm | BROWN |
| 6. BRAKE LIGHT | 1.5mm | RED |
| 7. LEFT TAIL/SIDE LIGHT | 1.5mm | BLACK |
| 8. REVERSE LIGHT | 1.5mm | ORANGE |
| 9. 12v PERMANENT | 2.5mm | BLUE/BROWN |
| 10. 12v IGNITION FEED | 2.5mm | RED/BROWN |
| 11. EARTH FOR POSITION 10 | 2.5mm | GREEN/WHITE |
| 12. UNUSED | | |
| 13. EARTH FOR POSITION 9 | 2.5mm | BLUE/WHITE |

THE SERVICE MANUAL

PHOENIX

DRAWING TEMPLATE-A CPO4
ISSUE DATE 23/02/2010 ISSUE 1

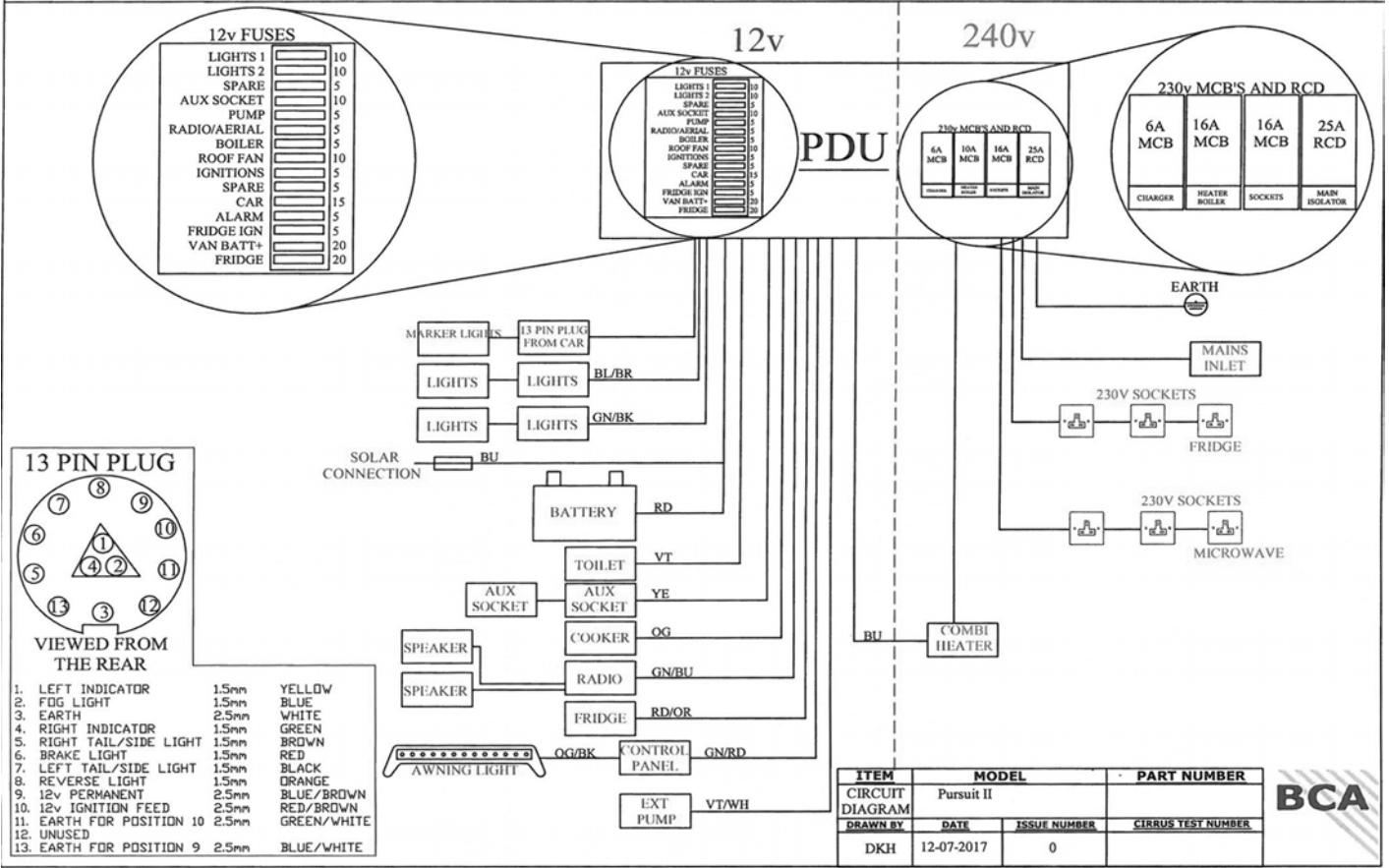

UNICORN IV SINGLE AXLE

DRAWING TEMPLATE-A CF048
ISSUE DATE 23/05/2019 ISSUE 1

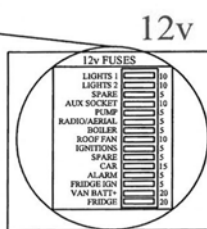
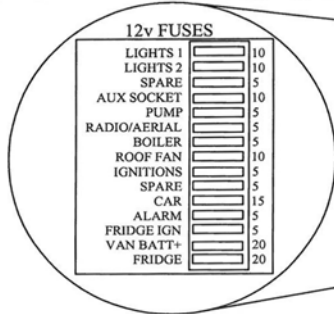

PDU

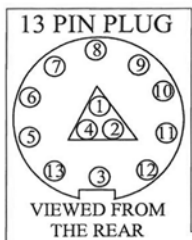
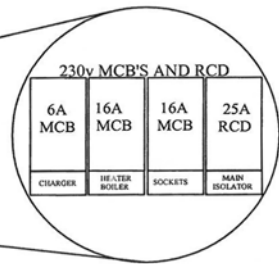
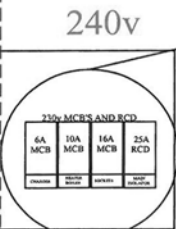

- | | | |
|---------------------------|-------|-------------|
| 1. LEFT INDICATOR | 1.5mm | YELLOW |
| 2. FOG LIGHT | 1.5mm | BLUE |
| 3. EARTH | 2.5mm | WHITE |
| 4. RIGHT INDICATOR | 1.5mm | GREEN |
| 5. RIGHT TAIL/SIDE LIGHT | 1.5mm | BROWN |
| 6. BRAKE LIGHT | 1.5mm | RED |
| 7. LEFT TAIL/SIDE LIGHT | 1.5mm | BLACK |
| 8. REVERSE LIGHT | 1.5mm | ORANGE |
| 9. 12v PERMANENT | 2.5mm | BLUE/BROWN |
| 10. 12v IGNITION FEED | 2.5mm | RED/BROWN |
| 11. EARTH FOR POSITION 10 | 2.5mm | GREEN/WHITE |
| 12. UNUSED | | |
| 13. EARTH FOR POSITION 9 | 2.5mm | BLUE/WHITE |

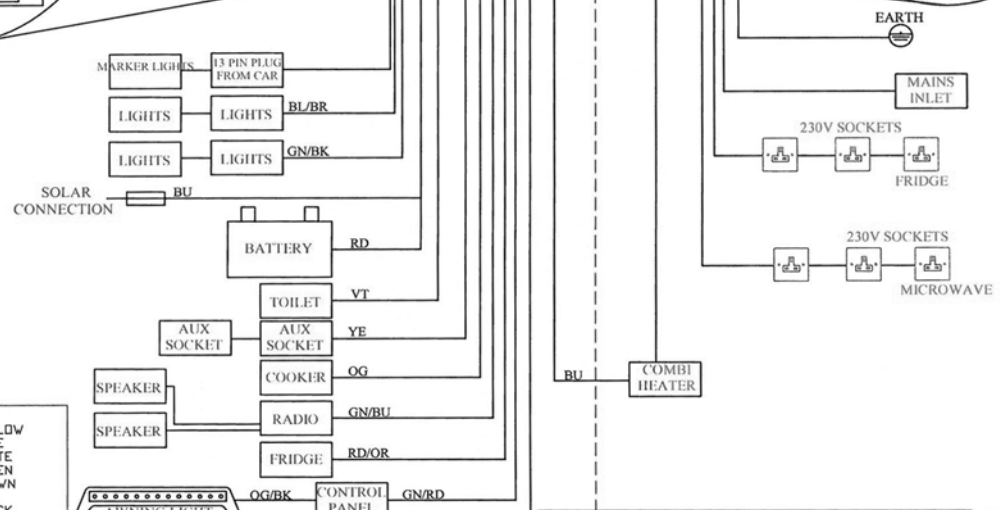

ITEM	MODEL	PART NUMBER
CIRCUIT DIAGRAM	Unicorn IV Single Axle	
DRAWN BY	DATE	ISSUE NUMBER
DKH	12-07-2017	0
		CIRRUS TEST NUMBER

BCA

UNICORN IV TWIN AXLE

DRAWING TEMPLATE: A CT048
ISSUE DATE 22/02/2010 ISSUE 1

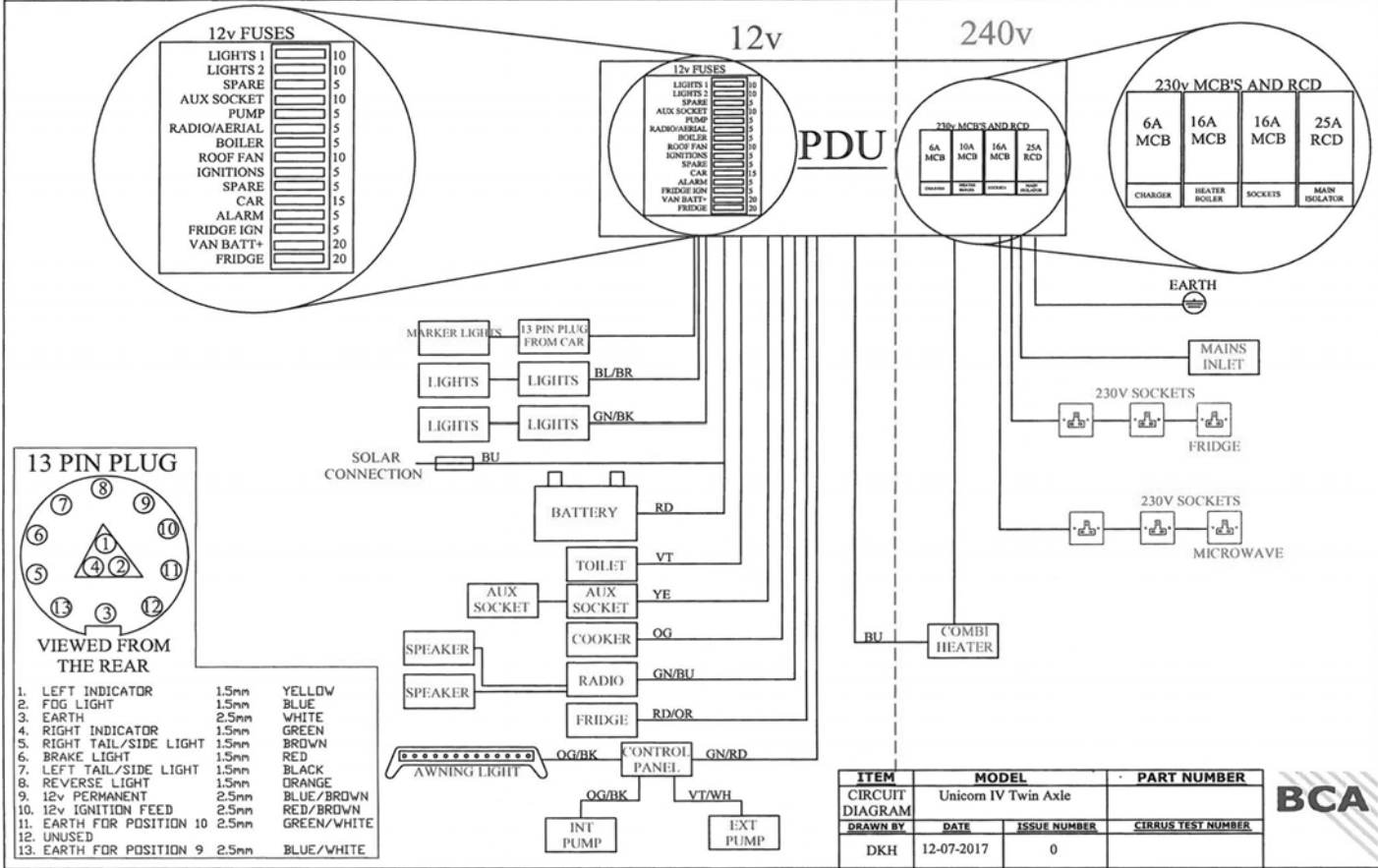

ITEM	MODEL	PART NUMBER
CIRCUIT DIAGRAM	Unicorn IV Twin Axle	
DRAWN BY	DATE	ISSUE NUMBER
DKH	12-07-2017	0
		CIRCUIT TEST NUMBER



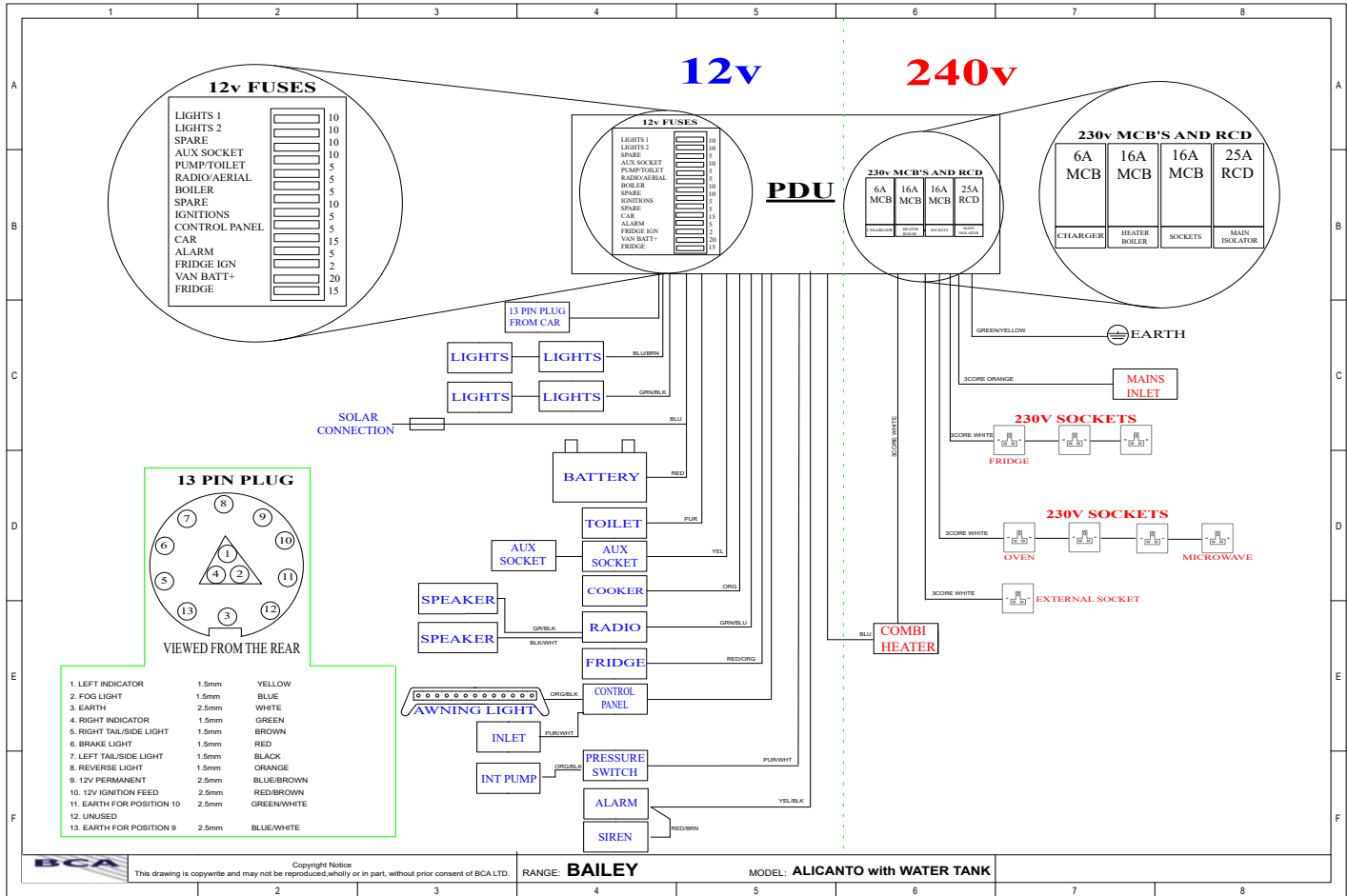

Copyright Notice
This drawing is copyright and may not be reproduced wholly or in part, without prior consent of BCA LTD.

RANGE: **BAILEY**

MODEL: **ALICANTO with WATER TANK**

If the caravan is sold before the end of the original warranty the remaining period can be transferred to the new owner using the warranty transfer form. There is a fee charged for this service of £35 including VAT.

Please send a copy of the Service Handbook, Proof of the purchase date along with this sheet and a copy of the service sheets from this service guide along with a cheque for £35 to Bailey of Bristol, South Liberty Lane, Bristol, BS3 2SS. Please make your cheque payable to "Bailey Caravans Ltd". We are unable to accept any other form of payment.

In order for the warranty to remain valid the caravan must have been serviced annually by an authorised Bailey Service Centre prior to the transfer of ownership. Failure to do so will invalidate any further warranty cover.

Failure to request this transfer within 3 months of acquisition by the new owner will invalidate the remaining warranty.

Terms and Conditions apply.

MODEL	_____
VIN NUMBER	_____
PURCHASE DATE	_____
PREVIOUS OWNER	_____
NEW OWNER	_____
NEW OWNER'S ADDRESS	_____ _____
NEW OWNER'S TELEPHONE NUMBER	_____
NEW OWNER'S EMAIL ADDRESS	_____
I have read and understood the terms and conditions of the warranty, including the servicing requirements, as applicable to this vehicle.	
Signed:	_____ Date: _____



PAGE LEFT BLANK INTENTIONALLY

If the caravan is sold before the end of the original warranty the remaining period can be transferred to the new owner using the warranty transfer form. There is a fee charged for this service of £35 including VAT.

Please send a copy of the Service Handbook, Proof of the purchase date along with this sheet and a copy of the service sheets from this service guide along with a cheque for £35 to Bailey of Bristol, South Liberty Lane, Bristol, BS3 2SS. Please make your cheque payable to "Bailey Caravans Ltd". We are unable to accept any other form of payment.

In order for the warranty to remain valid the caravan must have been serviced annually by an authorised Bailey Service Centre prior to the transfer of ownership. Failure to do so will invalidate any further warranty cover.

Failure to request this transfer within 3 months of acquisition by the new owner will invalidate the remaining warranty.

Terms and Conditions apply.

MODEL	_____
VIN NUMBER	_____
PURCHASE DATE	_____
PREVIOUS OWNER	_____
NEW OWNER	_____
NEW OWNER'S ADDRESS	_____ _____
NEW OWNER'S TELEPHONE NUMBER	_____
NEW OWNER'S EMAIL ADDRESS	_____
I have read and understood the terms and conditions of the warranty, including the servicing requirements, as applicable to this vehicle.	
Signed:	_____ Date: _____

If the caravan is sold before the end of the original warranty the remaining period can be transferred to the new owner using the warranty transfer form. There is a fee charged for this service of £35 including VAT.

Please send a copy of the Service Handbook, Proof of the purchase date along with this sheet and a copy of the service sheets from this service guide along with a cheque for £35 to Bailey of Bristol, South Liberty Lane, Bristol, BS3 2SS. Please make your cheque payable to "Bailey Caravans Ltd". We are unable to accept any other form of payment.

In order for the warranty to remain valid the caravan must have been serviced annually by an authorised Bailey Service Centre prior to the transfer of ownership. Failure to do so will invalidate any further warranty cover.

Failure to request this transfer within 3 months of acquisition by the new owner will invalidate the remaining warranty.

Terms and Conditions apply.

MODEL	_____
VIN NUMBER	_____
PURCHASE DATE	_____
PREVIOUS OWNER	_____
NEW OWNER	_____
NEW OWNER'S ADDRESS	_____ _____ _____
NEW OWNER'S TELEPHONE NUMBER	_____
NEW OWNER'S EMAIL ADDRESS	_____
I have read and understood the terms and conditions of the warranty, including the servicing requirements, as applicable to this vehicle.	
Signed:	_____ Date: _____

PAGE LEFT BLANK INTENTIONALLY

If the caravan is sold before the end of the original warranty the remaining period can be transferred to the new owner using the warranty transfer form. There is a fee charged for this service of £35 including VAT.

Please send a copy of the Service Handbook, Proof of the purchase date along with this sheet and a copy of the service sheets from this service guide along with a cheque for £35 to Bailey of Bristol, South Liberty Lane, Bristol, BS3 2SS. Please make your cheque payable to "Bailey Caravans Ltd". We are unable to accept any other form of payment.

In order for the warranty to remain valid the caravan must have been serviced annually by an authorised Bailey Service Centre prior to the transfer of ownership. Failure to do so will invalidate any further warranty cover.

Failure to request this transfer within 3 months of acquisition by the new owner will invalidate the remaining warranty.

Terms and Conditions apply.

MODEL	_____
VIN NUMBER	_____
PURCHASE DATE	_____
PREVIOUS OWNER	_____
NEW OWNER	_____
NEW OWNER'S ADDRESS	_____ _____ _____
NEW OWNER'S TELEPHONE NUMBER	_____
NEW OWNER'S EMAIL ADDRESS	_____
I have read and understood the terms and conditions of the warranty, including the servicing requirements, as applicable to this vehicle.	
Signed:	_____ Date: _____

PAGE LEFT BLANK INTENTIONALLY

If the caravan is sold before the end of the original warranty the remaining period can be transferred to the new owner using the warranty transfer form. There is a fee charged for this service of £35 including VAT.

Please send a copy of the Service Handbook, Proof of the purchase date along with this sheet and a copy of the service sheets from this service guide along with a cheque for £35 to Bailey of Bristol, South Liberty Lane, Bristol, BS3 2SS. Please make your cheque payable to "Bailey Caravans Ltd". We are unable to accept any other form of payment.

In order for the warranty to remain valid the caravan must have been serviced annually by an authorised Bailey Service Centre prior to the transfer of ownership. Failure to do so will invalidate any further warranty cover.

Failure to request this transfer within 3 months of acquisition by the new owner will invalidate the remaining warranty.

Terms and Conditions apply.

MODEL	_____
VIN NUMBER	_____
PURCHASE DATE	_____
PREVIOUS OWNER	_____
NEW OWNER	_____
NEW OWNER'S ADDRESS	_____ _____
NEW OWNER'S TELEPHONE NUMBER	_____
NEW OWNER'S EMAIL ADDRESS	_____
I have read and understood the terms and conditions of the warranty, including the servicing requirements, as applicable to this vehicle.	
Signed:	_____ Date: _____

PAGE LEFT BLANK INTENTIONALLY

If the caravan is sold before the end of the original warranty the remaining period can be transferred to the new owner using the warranty transfer form. There is a fee charged for this service of £35 including VAT.

Please send a copy of the Service Handbook, Proof of the purchase date along with this sheet and a copy of the service sheets from this service guide along with a cheque for £35 to Bailey of Bristol, South Liberty Lane, Bristol, BS3 2SS. Please make your cheque payable to "Bailey Caravans Ltd". We are unable to accept any other form of payment.

In order for the warranty to remain valid the caravan must have been serviced annually by an authorised Bailey Service Centre prior to the transfer of ownership. Failure to do so will invalidate any further warranty cover.

Failure to request this transfer within 3 months of acquisition by the new owner will invalidate the remaining warranty.

Terms and Conditions apply.

MODEL	_____
VIN NUMBER	_____
PURCHASE DATE	_____
PREVIOUS OWNER	_____
NEW OWNER	_____
NEW OWNER'S ADDRESS	_____ _____ _____
NEW OWNER'S TELEPHONE NUMBER	_____
NEW OWNER'S EMAIL ADDRESS	_____
I have read and understood the terms and conditions of the warranty, including the servicing requirements, as applicable to this vehicle.	
Signed:	_____ Date: _____

PAGE LEFT BLANK INTENTIONALLY

If the caravan is sold before the end of the original warranty the remaining period can be transferred to the new owner using the warranty transfer form. There is a fee charged for this service of £35 including VAT.

Please send a copy of the Service Handbook, Proof of the purchase date along with this sheet and a copy of the service sheets from this service guide along with a cheque for £35 to Bailey of Bristol, South Liberty Lane, Bristol, BS3 2SS. Please make your cheque payable to "Bailey Caravans Ltd". We are unable to accept any other form of payment.

In order for the warranty to remain valid the caravan must have been serviced annually by an authorised Bailey Service Centre prior to the transfer of ownership. Failure to do so will invalidate any further warranty cover.

Failure to request this transfer within 3 months of acquisition by the new owner will invalidate the remaining warranty.

Terms and Conditions apply.

MODEL	_____
VIN NUMBER	_____
PURCHASE DATE	_____
PREVIOUS OWNER	_____
NEW OWNER	_____
NEW OWNER'S ADDRESS	_____ _____ _____
NEW OWNER'S TELEPHONE NUMBER	_____
NEW OWNER'S EMAIL ADDRESS	_____
I have read and understood the terms and conditions of the warranty, including the servicing requirements, as applicable to this vehicle.	
Signed:	_____ Date: _____

PAGE LEFT BLANK INTENTIONALLY

If the caravan is sold before the end of the original warranty the remaining period can be transferred to the new owner using the warranty transfer form. There is a fee charged for this service of £35 including VAT.

Please send a copy of the Service Handbook, Proof of the purchase date along with this sheet and a copy of the service sheets from this service guide along with a cheque for £35 to Bailey of Bristol, South Liberty Lane, Bristol, BS3 2SS. Please make your cheque payable to "Bailey Caravans Ltd". We are unable to accept any other form of payment.

In order for the warranty to remain valid the caravan must have been serviced annually by an authorised Bailey Service Centre prior to the transfer of ownership. Failure to do so will invalidate any further warranty cover.

Failure to request this transfer within 3 months of acquisition by the new owner will invalidate the remaining warranty.

Terms and Conditions apply.

MODEL	_____
VIN NUMBER	_____
PURCHASE DATE	_____
PREVIOUS OWNER	_____
NEW OWNER	_____
NEW OWNER'S ADDRESS	_____ _____ _____
NEW OWNER'S TELEPHONE NUMBER	_____
NEW OWNER'S EMAIL ADDRESS	_____
I have read and understood the terms and conditions of the warranty, including the servicing requirements, as applicable to this vehicle.	
Signed:	_____ Date: _____

PAGE LEFT BLANK INTENTIONALLY

If the caravan is sold before the end of the original warranty the remaining period can be transferred to the new owner using the warranty transfer form. There is a fee charged for this service of £35 including VAT.

Please send a copy of the Service Handbook, Proof of the purchase date along with this sheet and a copy of the service sheets from this service guide along with a cheque for £35 to Bailey of Bristol, South Liberty Lane, Bristol, BS3 2SS. Please make your cheque payable to "Bailey Caravans Ltd". We are unable to accept any other form of payment.

In order for the warranty to remain valid the caravan must have been serviced annually by an authorised Bailey Service Centre prior to the transfer of ownership. Failure to do so will invalidate any further warranty cover.

Failure to request this transfer within 3 months of acquisition by the new owner will invalidate the remaining warranty.

Terms and Conditions apply.

MODEL	_____
VIN NUMBER	_____
PURCHASE DATE	_____
PREVIOUS OWNER	_____
NEW OWNER	_____
NEW OWNER'S ADDRESS	_____ _____
NEW OWNER'S TELEPHONE NUMBER	_____
NEW OWNER'S EMAIL ADDRESS	_____
I have read and understood the terms and conditions of the warranty, including the servicing requirements, as applicable to this vehicle.	
Signed:	_____ Date: _____

PAGE LEFT BLANK INTENTIONALLY

If the caravan is sold before the end of the original warranty the remaining period can be transferred to the new owner using the warranty transfer form. There is a fee charged for this service of £35 including VAT.

Please send a copy of the Service Handbook, Proof of the purchase date along with this sheet and a copy of the service sheets from this service guide along with a cheque for £35 to Bailey of Bristol, South Liberty Lane, Bristol, BS3 2SS. Please make your cheque payable to "Bailey Caravans Ltd". We are unable to accept any other form of payment.

In order for the warranty to remain valid the caravan must have been serviced annually by an authorised Bailey Service Centre prior to the transfer of ownership. Failure to do so will invalidate any further warranty cover.

Failure to request this transfer within 3 months of acquisition by the new owner will invalidate the remaining warranty.

Terms and Conditions apply.

MODEL	_____
VIN NUMBER	_____
PURCHASE DATE	_____
PREVIOUS OWNER	_____
NEW OWNER	_____
NEW OWNER'S ADDRESS	_____ _____
NEW OWNER'S TELEPHONE NUMBER	_____
NEW OWNER'S EMAIL ADDRESS	_____
I have read and understood the terms and conditions of the warranty, including the servicing requirements, as applicable to this vehicle.	
Signed:	_____ Date: _____

PAGE LEFT BLANK INTENTIONALLY

If the caravan is sold before the end of the original warranty the remaining period can be transferred to the new owner using the warranty transfer form. There is a fee charged for this service of £35 including VAT.

Please send a copy of the Service Handbook, Proof of the purchase date along with this sheet and a copy of the service sheets from this service guide along with a cheque for £35 to Bailey of Bristol, South Liberty Lane, Bristol, BS3 2SS. Please make your cheque payable to "Bailey Caravans Ltd". We are unable to accept any other form of payment.

In order for the warranty to remain valid the caravan must have been serviced annually by an authorised Bailey Service Centre prior to the transfer of ownership. Failure to do so will invalidate any further warranty cover.

Failure to request this transfer within 3 months of acquisition by the new owner will invalidate the remaining warranty.

Terms and Conditions apply.

MODEL	_____
VIN NUMBER	_____
PURCHASE DATE	_____
PREVIOUS OWNER	_____
NEW OWNER	_____
NEW OWNER'S ADDRESS	_____ _____ _____
NEW OWNER'S TELEPHONE NUMBER	_____
NEW OWNER'S EMAIL ADDRESS	_____
I have read and understood the terms and conditions of the warranty, including the servicing requirements, as applicable to this vehicle.	
Signed:	_____ Date: _____

Leisure Batteries

with OE Pedigree



Energy Bull

The official power supply on all Bailey Caravan and Motorhome vehicles.



Power Evolved

The power of Banner Batteries has not only evolved through ongoing product innovation combined with world class manufacturing, but an unparalleled OE pedigree that is the backbone of the company's genetic make-up.



Banner

THE POWER COMPANY

www.bannerbatteries.com t: 01889 571100



Caravan Owners Manual October 2020

