



PEGASUS

Alu-Tech Bodysell

Service Handbook



*For life's most
memorable journeys*
www.baileypegusus-s2.co.uk

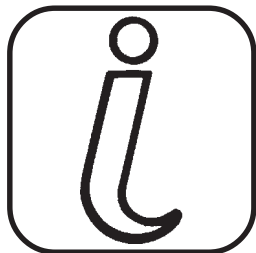

Annual Service Record	2-4
Warranty	5-7
Specification	8-9
Wiring Diagrams	10-12
Fuse/MCB Specification	13
Bulb, Tube & Fuse Specification	14
Awning Sizes	15
Moisture Test	16
Thermal Insulation	16



ANNUAL SERVICE RECORD

CARAVAN MODEL _____ YEAR _____

CHASSIS NUMBER _____

2000 MILES OR 1 YEAR AFTER DELIVERY STANDARD CARAVAN SERVICE INCLUDING MOISTURE SURVEY	4000 MILES OR 2 YEARS AFTER DELIVERY STANDARD CARAVAN SERVICE INCLUDING MOISTURE SURVEY
<i>DEALER STAMP</i>	<i>DEALER STAMP</i>
DATE VIN No.	DATE VIN No.
6000 MILES OR 3 YEARS AFTER DELIVERY STANDARD CARAVAN SERVICE INCLUDING MOISTURE SURVEY Plus security check of body shell fixing clamps	8000 MILES OR 4 YEARS AFTER DELIVERY STANDARD CARAVAN SERVICE INCLUDING MOISTURE SURVEY
<i>DEALER STAMP</i>	<i>DEALER STAMP</i>
DATE VIN No.	DATE VIN No.

ANNUAL SERVICE RECORD



10000 MILES OR 5 YEARS AFTER DELIVERY STANDARD CARAVAN SERVICE INCLUDING MOISTURE SURVEY	12000 MILES OR 6 YEARS AFTER DELIVERY STANDARD CARAVAN SERVICE INCLUDING MOISTURE SURVEY
<i>DEALER STAMP</i>	<i>DEALER STAMP</i>
DATE VIN No.	DATE VIN No.
14000 MILES OR 7 YEARS AFTER DELIVERY STANDARD CARAVAN SERVICE INCLUDING MOISTURE SURVEY	16000 MILES OR 8 YEARS AFTER DELIVERY STANDARD CARAVAN SERVICE INCLUDING MOISTURE SURVEY
<i>DEALER STAMP</i>	<i>DEALER STAMP</i>
DATE VIN No.	DATE VIN No.



ANNUAL SERVICE RECORD

CARAVAN MODEL _____ YEAR _____

CHASSIS NUMBER _____

18000 MILES OR 9 YEARS AFTER DELIVERY STANDARD CARAVAN SERVICE INCLUDING MOISTURE SURVEY	20000 MILES OR 10 YEARS AFTER DELIVERY STANDARD CARAVAN SERVICE INCLUDING MOISTURE SURVEY
<i>DEALER STAMP</i>	<i>DEALER STAMP</i>
DATE VIN No.	DATE VIN No.

WARRANTY



PEGASUS CARAVAN WARRANTY COVER

Total customer satisfaction is top priority at Bailey and the quality ethos extends to the after sales service and market leading manufacturer's warranty package that comes with every new Bailey Pegasus caravan. In this way we not only ensure long-term peace of mind but also enhance the re-sale value of your investment.

6 Year Body Shell Integrity Guarantee

The Bailey Alu-Tech Pegasus caravan is covered by a six (6) year Bodyshell Integrity Guarantee from the initial date of purchase. This cover extends to any structural degradation to the bodyshell that arises as a result of water ingress through any permanently sealed seams or joints (with the exception of exclusions stated in the terms and conditions.)

Warranty Extension

An additional four (4) year extension to the standard Bodyshell Integrity Guarantee warranty cover (making 10 years cover in total) is available as a cost option. Please ask your supplying Bailey Retailer for more information.

3 Year Manufacturer's Warranty

For a period of twenty-four (24) months from the initial date of purchase Bailey of Bristol offer a comprehensive warranty on all parts and components as well as full coverage for any manufacturing faults forming part of the original specification of the vehicle. The manufacturer's warranty then extends to an additional twelve (12) months on the following items

Chassis: all chassis members including corner steadies

Suspension: axle suspension and braking system (excluding any damage to or faults in brake drums and shoes that are caused through misuse of the braking system or from normal wear and tear)

Running Gear: road wheels (excluding tyres)

Towing Mechanism: all mechanical components fitted to vehicle (excluding electrics)

Cooker: the cooker unit including burners, grill, oven, hot plate, flame failure device and igniter

Refrigerator: door seal condenser, gas control valve, gas igniter, flame failure device, 230v heater elements, gas thermostat, thermostat and temperature control switch

Water System: water heater (gas or electric), fresh water tank, water pump, water gauges, taps and shower head

Electrical System: mains hook up input connector, ELCB, and interior lighting units (excluding bulbs and LED's)

Cassette Toilet: the cassette toilet is covered (excluding seals, valves and glands)

Heating System: thermostat, motor, switches, control unit, gas heater, flame failure device and igniter (excluding ducting and fittings)

Windows: the functionality of the opening and closing system (stays, handles and catches) and a warranty against the cracking of the acrylic

Upholstery: zips, seams and colour fastness.

Warranty Extension

An additional three (3) year extension to the standard Manufacturer's Warranty cover (making 6 years cover in total) is available as a cost option. Please ask your supplying Bailey Retailer for more information.

Customer Support

In the unusual event of something going wrong your first contact should always be your supplying retailer. Approved Bailey Retailers enjoy industry-leading after sales support service from the manufacturer and they should be able to offer all the help you need to rectify any problems that may exist.



Terms and Conditions

The Bailey Warranty Cover set out above is offered subject to the following simple terms and conditions:

Cover

- 1 During the term of the Warranty Cover, subject to these terms and conditions, Bailey will, through an Authorised Service Centre, at its option repair or replace all parts and components of the Pegasus caravan that are included in the Warranty Cover and which suffer a defect in manufacture or workmanship. An Authorised Service Centre means either Bailey itself, a Bailey Approved Retailer or a Bailey Approved Service Centre. Any part which is replaced becomes the property of Bailey. Any replacement parts are covered for the unexpired term of the Warranty Cover.

Term

- 2 The initial duration of the Bodyshell Integrity Guarantee is six (6) years and the duration of the Manufacturer's Warranty is three (3) years in both cases starting from the original purchase date of the vehicle. It is a condition of the warranty that an annual service is performed on the vehicle in accordance with the service plan. Failure to comply with this term will invalidate the warranty.
- 3 The unexpired term of the Warranty Cover on your vehicle may only be assigned, transferred or novated to subsequent owners with Bailey's consent (not to be unreasonably withheld) and on payment to Bailey of a transfer fee of £35. Transfer can only be made within the first three months (3) of subsequent ownership and full documentary evidence that the vehicle has been serviced annually must be provided at the time of assignment in accordance with the terms and conditions detailed above.

Repairs

- 4 The Pegasus caravan must undergo a full annual service and inspection, including a moisture survey, carried out, subject to paragraph 5 below, by an Authorised Service Centre. The final annual service in the warranty period must be carried out before the end of that warranty period, but all other annual services may be carried out within six (6) weeks either side of each anniversary of the original purchase date. The original VAT invoices must be retained as proof that these annual inspections have been carried out.
- 5 During the first three (3) years of the Warranty Cover, all annual inspections and repairs must be carried out either by Bailey itself or an approved Bailey Service Centre or Agent. Thereafter, due to the technical nature of an Alu-Tech constructed caravan, annual inspections and repairs may be carried out by any workshop or repair centre approved by the National Caravan Council that has attended Alu-Tech training courses at the Bailey factory.
- 6 Where an annual inspection identifies that repairs to the vehicle are necessary, the Pegasus caravan must be made available for repair within six (6) weeks of the date of inspection for the purpose of carrying out the repair work.
- 7 No repairs, including the fitting of any replacement unit, may be undertaken or commenced under the terms of the Warranty Cover unless prior written authorisation is obtained from Bailey via an authorised Bailey Retailer or Service Centre. No liability will exist with regard to any warranty claims not authorised in this way.
- 8 Bailey reserve the right to examine the vehicle before any repairs commence or any replacement part is fitted.

Registration & Use

- 9 The Warranty Registration Form must have been sent to Bailey within six (6) weeks of the original purchase date. It is the responsibility of the Bailey Retailer to forward this information to Bailey. This is part of the terms of trading that the Bailey Retailer has with Bailey.
- 10 The Pegasus caravan shall:
 - a) only be used for its ordinary and intended purpose and shall not be subjected to any treatment or conditions which could reasonably be foreseen to cause or result in damage to the vehicle or excessive wear and tear;

WARRANTY



- (b) only be towed by a private car or private 4 x 4 vehicle; and
- (c) not be put out to hire, reward or any other commercial use, nor used in any race, competitions or rallies whether timed, official or otherwise.

Exclusions & Liability

- 11 Bailey's liability under this warranty shall be limited to supplying the reasonable costs of labour and materials required for the repair or replacement of faulty parts or components. Bailey shall be entitled to charge for any repair work which is necessitated by virtue of any loss or damage caused by your negligence or default or incurred as a result of any modifications you have made to the vehicle. This warranty does not cover repair costs other than labour and materials.
- 12 The Warranty Cover does not include:
 - (a) repair or replacement of parts, components, seams or panels which are not part of the original construction of the Pegasus caravan, or which have been tampered with or undergone unauthorised modifications, or which have been repaired otherwise than by an Authorised Service Centre;
 - (b) parts or components other than those specifically listed in the Bodysell Integrity Guarantee and Manufacturer's Warranty descriptions set out above;
 - (c) general maintenance or components failing due to fair wear and tear or normal deterioration;
 - (d) repairs necessitated by lack of routine or regular maintenance. Particular attention is drawn to the Owner's Manual and Service Handbook supplied with the caravan and any maintenance instructions or notices published from time to time by Bailey relating to the proper care and maintenance of vehicles; or
 - (e) structural degradation or other damage caused by water ingress through non-permanently sealed seams or joints (such as, without limitation, around windows, hatches, doors and rooflights), beyond the initial 24 months of the Manufacturer's Warranty.
- 13 No liability will be accepted for:
 - (a) damage caused by neglect or abuse, corrosion, intrusion of foreign or deleterious substances, lack of servicing, over-heating, freezing, or the continued use of the vehicle after a fault has become evident;
 - (b) any loss or damage caused by parts not covered by this Warranty Cover, including soft furnishings or trim;
 - (c) any accidental or fire damage or any losses incurred by accident or fire; or
 - (d) transport costs to and from point of repair.
- 14 Bailey will only be liable for costs which are incurred as a direct consequence of the event, defect or fault leading to the claim being made under this warranty. No liability will be accepted for any other loss or damage (such as loss of income or revenue, or loss of business or profits), costs, expenses or other claims for compensation howsoever arising which was not reasonably foreseeable by both parties when the caravan was originally purchased. Bailey will not be liable for any loss or damage suffered by third parties, nor for bodily injury not caused by our negligence.
- 15 Nothing in this warranty shall limit in any way our liability: for death or personal injury caused by our negligence; for fraud or fraudulent misrepresentation; or for any matter for which it would be illegal for us to exclude, or attempt to exclude, our liability.
- 16 The purchaser has statutory rights in addition to this warranty and this warranty does not affect those statutory rights.
- 17 This warranty shall be governed by and construed in accordance with the laws of England and the parties irrevocably submit to the non-exclusive jurisdiction of the courts of England.

The name and address of the warranty and guarantee provider is: Bailey Caravans Limited, South Liberty Lane, Bristol, BS3 2SS



SPECIFICATIONS

MODEL	BERTHS	INTERNAL BODY LENGTH	SHIPPING LENGTH	OVERALL BODY WIDTH	OVERALL HEIGHT	MAXIMUM HEADROOM	TYRE SIZES
GENOA	2	4.902m (16' 1")	6.475m (21' 3")	2.28m (7' 6")	2.63m (8' 8")	1.96m (6' 5")	185 R14 LI 104N
MILAN	4	5.678m (18' 8")	7.251m (23' 9")	2.28m (7' 6")	2.63m (8' 8")	1.96m (6' 5")	185 R14 LI 104N
VERONA	4	5.678m (18' 8")	7.251m (23' 9")	2.28m (7' 6")	2.63m (8' 8")	1.96m (6' 5")	185 R14 LI 104N
RIMINI	4	5.678m (18' 8")	7.251m (23' 9")	2.28m (7' 6")	2.63m (8' 8")	1.96m (6' 5")	185 R14 LI 104N
ANCONA	6	5.678m (18' 8")	7.251m (23' 9")	2.28m (7' 6")	2.63m (8' 8")	1.96m (6' 5")	185 R14 LI 104N
BOLOGNA	4	6.292m (20' 8")	7.865m (25' 10")	2.28m (7' 6")	2.63m (8' 8")	1.96m (6' 5")	185/65 R14 LI 193N



- ▲ The M.T.P.L.M. must not be exceeded. The maximum towing speed at M.T.P.L.M. for all models is 81 m.p.h. (130 k.m.p.h.)
- ▲ The maximum vertical static load for the coupling head or the maximum vertical load on the towing ball specified for the towing vehicle must not be exceeded.

** Figures quoted for when tyre is cold.

Steel wheel rim size: 5½J x 14 H2 ET30, 112mm PCD 5 stud.

Alloy wheel rim size: 6J x 14 H2 ET30, 112mm PCD 5 stud

SPECIFICATIONS



MODEL	TYRE PRESSURE (P.S.I./BAR) **	MAXIMUM TECHNICAL PERMISSIBLE LADEN MASS	M.R.O.	PAYLOAD ALLOWANCE FOR OPTIONAL EQUIPMENT	TOTAL USER PAYLOAD
GENOA	65 / 4.5	1356kg (26.7 cwt)	1215kg (23.9 cwt)	15kg (0.3 cwt)	141kg (2.8 cwt)
MILAN	65 / 4.5	1499kg (29.5 cwt)	1331kg (26.2 cwt)	15kg (0.3 cwt)	168kg (3.3 cwt)
VERONA	65 / 4.5	1490kg (29.3 cwt)	1322kg (26.0 cwt)	15kg (0.3 cwt)	168kg (3.3 cwt)
RIMINI	65 / 4.5	1499kg (29.5 cwt)	1330kg (26.2 cwt)	15kg (0.3 cwt)	169kg (3.3 cwt)
ANCONA	65 / 4.5	1499kg (29.5 cwt)	1311kg (25.8 cwt)	15kg (0.3 cwt)	188kg (3.7 cwt)
BOLOGNA	54 / 3.75	1670kg (32.9 cwt)	1495kg (29.4 cwt)	15kg (0.3 cwt)	175kg (3.4 cwt)



- ▲ The M.T.P.L.M. must not be exceeded. The maximum towing speed at M.T.P.L.M. for all models is 81 m.p.h. (130 k.m.p.h.)
- ▲ The maximum vertical static load for the coupling head or the maximum vertical load on the towing ball specified for the towing vehicle must not be exceeded.

** Figures quoted for when tyre is cold.

Steel wheel rim size: 5 $\frac{1}{2}$ J x 14 H2 ET30, 112mm PCD 5 stud.

Alloy wheel rim size: 6J x 14 H2 ET30, 112mm PCD 5 stud



ROADLIGHT WIRING — PEGASUS

NOTE: ALL CABLE SIZES GIVEN IN MM²

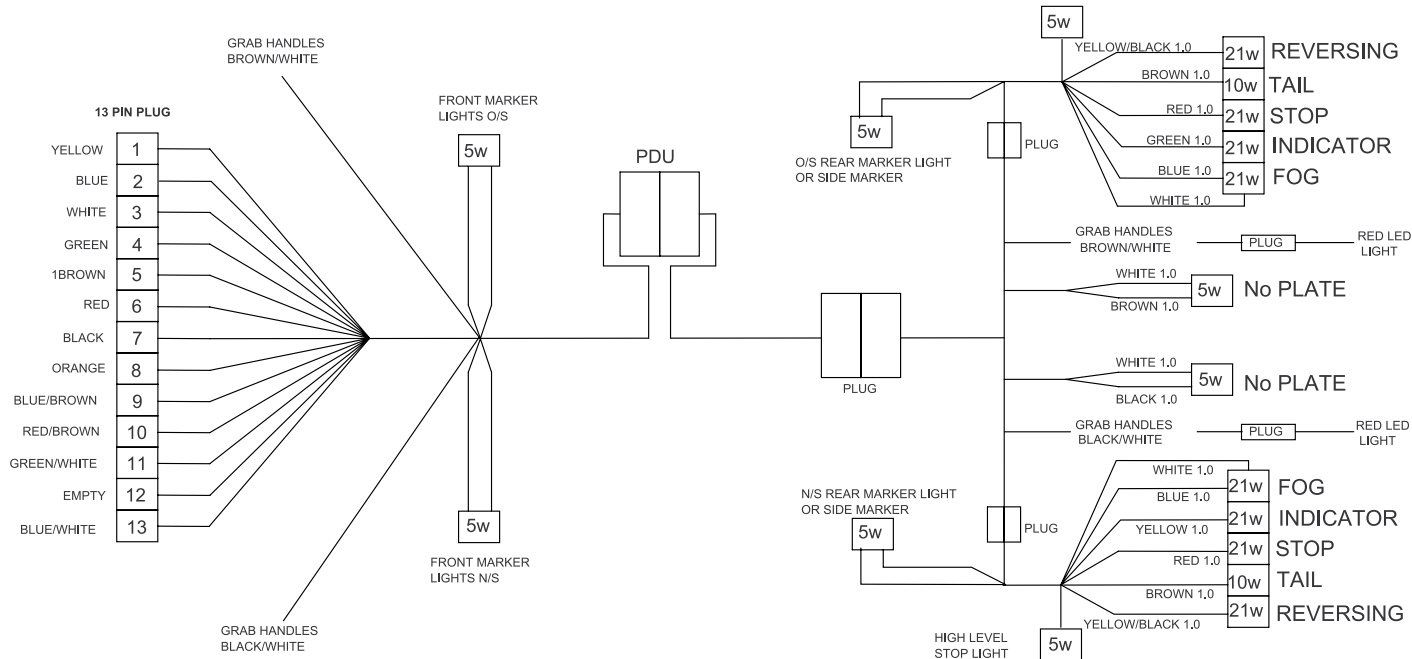

WIRING DIAGRAMS



230 VOLT & 12 VOLT PRIMARY CIRCUIT DIAGRAM - PEGASUS

- COLOUR KEY**
- O/O-ORANGE/GREEN
 - YEL-YELLOW(AUX)
 - Y-YELLOW(C/P)
 - RD-RED
 - WH-WHITE
 - BL-BLUE
 - RD/O-RED/ORANGE
 - O-ORANGE
 - BL/RD-BLUE/RED
 - G/B-GREEN/BLUE
 - G/RD-GREEN/RED
 - O/BLK-ORANGE/BLACK
 - G/BK-GREEN/BROWN
 - BW-BLACK/WHITE
 - G-GREEN
 - B/BK-BLUE/BLACK
 - G/BK-GREEN/BLACK
 - P-PURPLE
 - B-BLACK
 - O/W-ORANGE/WHITE
 - GY-GREY
 - Y/B-YELLOW/BLACK

CONNECTIONS FROM 13 PIN PLUG

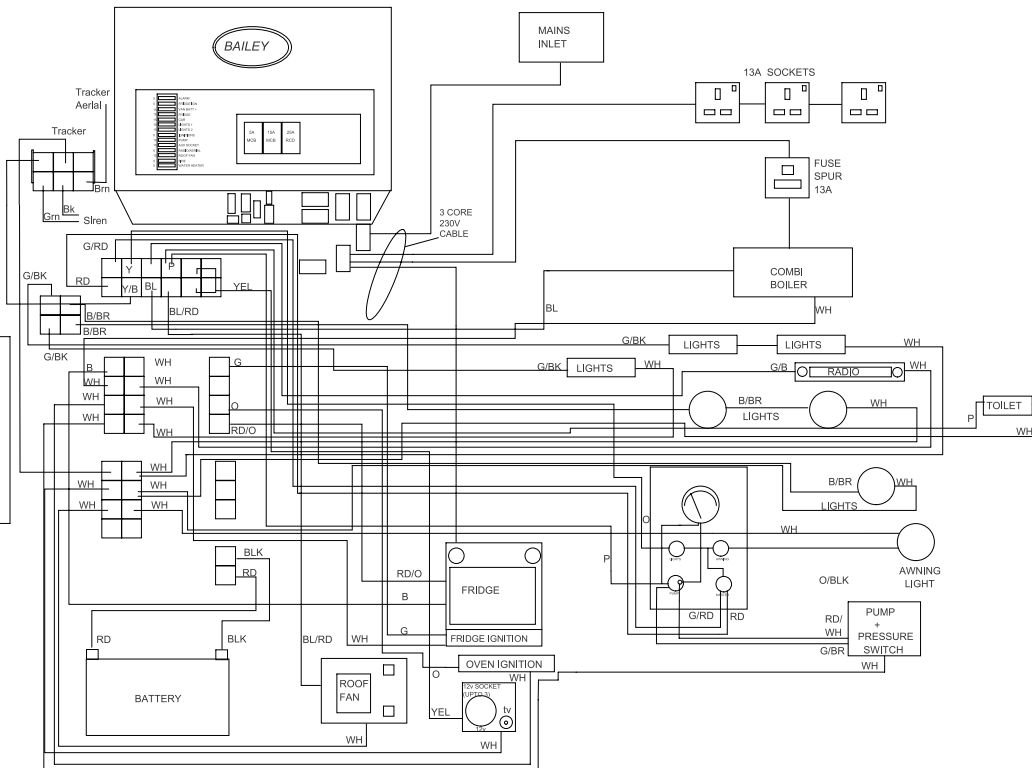
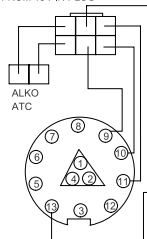

PEGASUS CONTROL PANEL DIAGRAM

VIEWED FROM REAR

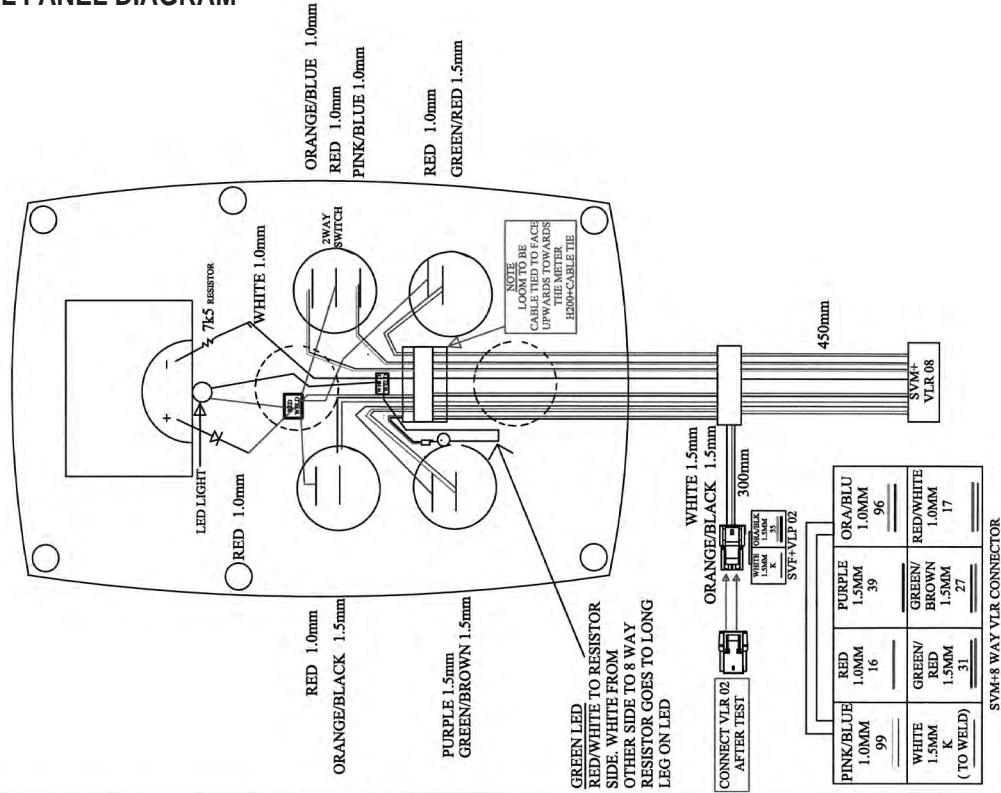

FUSE/MCB SPECIFICATION - PEGASUS

FUSES

Fridge Ign	5 amp (yellow)
Caravan battery	15 amp (blue)
Fridge	15 amp (blue)
Car	15 amp (blue)
Lights 1	15 amp (blue)
Lights 2	15 amp (blue)
Ignitions	5 amp (yellow)
Pump	10 amp (red)
Aux socket	10 amp (red)
Radio/aerial	5 amp (yellow)
Roof fan feed	10 amp (red)
Fire	5 amp (yellow)
Water heater	5 amp (yellow)
Truma Ultrastore	230V 5 amp cartridge
Refrigerator	230V 3 amp cartridge
Truma Ultraheat	230V 10/13 amp cartridge
Smoke alarm battery	9 volt PP9



BULB, TUBE & FUSE SPECIFICATION - PEGASUS

ROAD LIGHTS

Front and rear grab handles	12 volt	< 1 watt	LED	BCA
Front marker light	12 volt	< 1 watt	LED	Jokon
Side marker light	12 volt	5 watt	Bayonet	Clear
Brake lights (low level)	12 volt	21 watt	Bayonet	Clear
Side marker light (low level)	12 volt	< 1 watt	LED	Jokon
Fog lights	12 volt	21 watt	Bayonet	Clear
Indicator	12 volt	21 watt	Bayonet	Orange
Number plate light	12 volt	10 watt	Festoon	Clear
High level brake light	12 volt	21 watt	Bayonet	Clear
Reversing light	12 volt	21 watt	Bayonet	Clear

INTERIOR LIGHTS

Fluorescent lights	12 volt	8 watt		
LED spotlights	12 volt	< 1 watt	LED	Sargent
Double locker LED	12 volt	< 2 watt	LED	BCA
Single locker LED	12 volt	< 1 watt	LED	BCA
Ciro ceiling light	12 volt	2 x 10 watt	G4	Ring
T/C and vanity downlighter	12 volt	10 watt	G4	Ring
Awning light	12 volt	< 1 watt	LED	BCA

AWNING SIZES

The following are the ground to ground dimensions through the awning channel. These dimensions are issued as a guideline only, please refer to your dealer for the correct awning size to suit your particular caravan.

PEGASUS	Genoa	968 cms
	Milan	1046 cms
	Verona	1046 cms
	Rimini	1046 cms
	Ancona	1046 cms
	Bologna	1113 cms



PEGASUS SERVICE SCHEDULE

In order to validate the factory backed warranty package, your caravan must be serviced by an approved Bailey Service Centre every 12 months (or within 6 weeks of each anniversary of purchase) in accordance with the NCC recommended service schedule.

A full listing of the current Approved Bailey Centres can be found on the Retailer Network pages of our web site @ www.bailey-caravans.co.uk. Alternatively please contact our Customer Helpline on 0117-3052939 for details of your local service agent.

ALU-TECH CONSTRUCTION SERVICE SCHEDULE

All Bailey caravans must undergo a full annual service and inspection from new, including a moisture survey, carried out, by an Approved Bailey Service Centre in order to validate the warranty. The final annual service in the warranty period must be carried out before the end of that warranty period, but all other annual services may be carried out within six (6) weeks either side of each anniversary of the original purchase date. The original VAT invoices must be retained as proof that these annual inspections have been carried out.

Warning: In no circumstances should the body shell fixings be tampered with or adjusted by the caravan owner. In instances where this has occurred the warranty will be automatically invalidated.

STANDARD MOISTURE SURVEY FOR ALU-TECH CONSTRUCTION CARAVANS

The following moisture survey must be carried out using a calibrated moisture meter every 12 months by an Approved Bailey Service Centre.

Readings should be taken on the floor section of the caravan in positions where the holes created by the meter's probe are not visible, i.e. behind seals, in bedboxes or in cupboard bases. It is important to make sure that the probes are free of moisture and the surface of the floor is free from condensation.

Readings below 20% are considered acceptable. Readings greater than 20% will identify areas needing further investigation and possibly remedial work.

All other parts of the body of the Alu-Tech caravan should be checked visually for moisture ingress.

THERMAL INSULATION GRADING

All Bailey Alu-Tech Caravans are manufactured and approved by the NCC to EN1646-1 thermal insulation and heating classification Grade III. This has been approved using the caravan space heater using both the heating and gas as the heating method.

Grade III is classified as being able to achieve an average temperature difference of 35 degrees centigrade between inside the caravan and outside when the exterior temperature is -15 degrees outside.

WARRANTY TRANSFER FORM



If the vehicle is sold before the end of the original warranty the benefit of the remaining period can be transferred to the new owner using the warranty transfer form. There is a fee charged for this service of £35 + VAT.

Failure to request this transfer within 14 days of acquisition by the new owner will invalidate the remaining warranty.

Model	
Chassis number	
Bailey Production Number	
Purchase Date	
Previous Owner	
New Owner's Address	
Telephone Number	
Email	

I have read and understand the terms and conditions of the warranty, including the servicing requirements, as applicable to this vehicle

Signed:

Date:

INTENTIONALLY LEFT BLANK

WARRANTY TRANSFER FORM



If the vehicle is sold before the end of the original warranty the benefit of the remaining period can be transferred to the new owner using the warranty transfer form. There is a fee charged for this service of £35 + VAT.

Failure to request this transfer within 14 days of acquisition by the new owner will invalidate the remaining warranty.

Model	
Chassis number	
Bailey Production Number	
Purchase Date	
Previous Owner	
New Owner's Address	
Telephone Number	
Email	

I have read and understand the terms and conditions of the warranty, including the servicing requirements, as applicable to this vehicle

Signed:

Date:

INTENTIONALLY LEFT BLANK

WARRANTY TRANSFER FORM



If the vehicle is sold before the end of the original warranty the benefit of the remaining period can be transferred to the new owner using the warranty transfer form. There is a fee charged for this service of £35 + VAT.

Failure to request this transfer within 14 days of acquisition by the new owner will invalidate the remaining warranty.

Model	
Chassis number	
Bailey Production Number	
Purchase Date	
Previous Owner	
New Owner's Address	
Telephone Number	
Email	

I have read and understand the terms and conditions of the warranty, including the servicing requirements, as applicable to this vehicle

Signed:

Date:

INTENTIONALLY LEFT BLANK

WARRANTY TRANSFER FORM



If the vehicle is sold before the end of the original warranty the benefit of the remaining period can be transferred to the new owner using the warranty transfer form. There is a fee charged for this service of £35 + VAT.

Failure to request this transfer within 14 days of acquisition by the new owner will invalidate the remaining warranty.

Model	
Chassis number	
Bailey Production Number	
Purchase Date	
Previous Owner	
New Owner's Address	
Telephone Number	
Email	

I have read and understand the terms and conditions of the warranty, including the servicing requirements, as applicable to this vehicle

Signed:

Date:





Bailey Caravans, South Liberty Lane, Bristol BS3 2SS

www.bailey-caravans.co.uk