

Annual Service Record	2-4
Warranty	5-7
Specification	8-9
Wiring Diagrams	10-12
Fuse/MCB Specification	13
Bulb, Tube & Fuse Specification	14
Awning Sizes	15
Moisture Test	16
Thermal Insulation	16



ANNUAL SERVICE RECORD

CARAVAN MODEL _____ YEAR _____

CHASSIS NUMBER _____

2000 MILES OR 1 YEAR AFTER DELIVERY STANDARD CARAVAN SERVICE INCLUDING MOISTURE SURVEY	4000 MILES OR 2 YEARS AFTER DELIVERY STANDARD CARAVAN SERVICE INCLUDING MOISTURE SURVEY
<i>DEALER STAMP</i>	<i>DEALER STAMP</i>
DATE VIN No.	DATE VIN No.
6000 MILES OR 3 YEARS AFTER DELIVERY STANDARD CARAVAN SERVICE INCLUDING MOISTURE SURVEY Plus security check of body shell fixing clamps	8000 MILES OR 4 YEARS AFTER DELIVERY STANDARD CARAVAN SERVICE INCLUDING MOISTURE SURVEY
<i>DEALER STAMP</i>	<i>DEALER STAMP</i>
DATE VIN No.	DATE VIN No.

ANNUAL SERVICE RECORD



10000 MILES OR 5 YEARS AFTER DELIVERY STANDARD CARAVAN SERVICE INCLUDING MOISTURE SURVEY	12000 MILES OR 6 YEARS AFTER DELIVERY STANDARD CARAVAN SERVICE INCLUDING MOISTURE SURVEY
<i>DEALER STAMP</i>	<i>DEALER STAMP</i>
DATE VIN No.	DATE VIN No.
14000 MILES OR 7 YEARS AFTER DELIVERY STANDARD CARAVAN SERVICE INCLUDING MOISTURE SURVEY	16000 MILES OR 8 YEARS AFTER DELIVERY STANDARD CARAVAN SERVICE INCLUDING MOISTURE SURVEY
<i>DEALER STAMP</i>	<i>DEALER STAMP</i>
DATE VIN No.	DATE VIN No.



ANNUAL SERVICE RECORD

CARAVAN MODEL _____ YEAR _____

CHASSIS NUMBER _____

18000 MILES OR 9 YEARS AFTER DELIVERY STANDARD CARAVAN SERVICE INCLUDING MOISTURE SURVEY	20000 MILES OR 10 YEARS AFTER DELIVERY STANDARD CARAVAN SERVICE INCLUDING MOISTURE SURVEY
<i>DEALER STAMP</i>	<i>DEALER STAMP</i>
DATE VIN No.	DATE VIN No.

BAILEY PEGASUS WARRANTY COVER

Total customer satisfaction is top priority at Bailey and the quality ethos extends to the after sales service and manufacturer's warranty that comes with every new Bailey touring caravan. In this way we not only ensure long-term peace of mind but also enhance the resale value of your investment.

10 Year Body Shell Integrity Guarantee

The Bailey Alu-Tech caravan is covered by a ten (10) year Bodyshell Integrity Guarantee, which comprises of a six (6) year standard warranty cover and a four (4) year chargeable extension to the standard warranty cover. This cover extends to any structural degradation to the bodyshell that arises as a result of water ingress through any permanently sealed seams or joints.

3 Year Manufacturers Warranty

For a period of twenty-four (24) months from the initial date of purchase, Bailey offer a comprehensive warranty on all parts and components, as well as full coverage for any manufacturing faults forming part of the original specification of the caravan. The manufacturer's warranty then extends to an additional twelve (12) months on the following items:

Chassis: all chassis members including corner steadies.

Suspension: axle, suspension and braking system (excluding any damage to, or faults in brake drums and shoes that are caused through misuse of the braking system or from normal wear and tear).

Running Gear: road wheels (excluding tyres).

Towing Mechanism: all mechanical components fitted to caravans (excluding electrics).

Cooker: the oven unit including hob, burners, grill, oven and flame failure device and igniter.

Fridge: door seal, condenser, gas control valve, gas igniter, flame failure device, 12 and 230v heater elements, gas thermostat, 230v thermostat, 230v temperature control switch.

Water System: water heater (gas or electric), fresh water tank, water pump, water gauges, taps and shower head.

Auxiliary Electrics: mains hook-up input connector, ELCB, battery charger and distributor unit, interior lighting units (excluding bulbs and LEDs).

Cassette Toilet: the cassette toilet is covered (excluding seals, valves and glands).

Heating System: thermostat, motor, switches, control unit, gas heater, flame failure device, igniter (excluding ducting and fittings).

Windows: the functionality of the opening and closing system (stays, handles and catches) and a warranty against the cracking of the acrylic.

Upholstery: zips, seams and colour fastness.

Warranty Extensions

An additional 7th, 8th, 9th and 10th year extension to the Bodyshell Integrity Guarantee is available at an additional cost. An additional 4th, 5th and 6th year extension to the Manufacturer's Warranty is also available. Please ask your Bailey retailer for more information.



Customer Support

In the unusual event of something going wrong your first contact should always be your supplying retailer. Approved Bailey Retailers enjoy industry-leading after sales support service from the manufacturer and they should be able to offer all the help you need to rectify any problems that may exist.

Terms and Conditions

The Bailey Warranty Cover set out above is offered subject to the following simple terms and conditions:

Cover

- 1 During the term of the Warranty Cover, subject to these terms and conditions, Bailey will, through an Authorised Service Centre, at its option repair or replace all parts and components of the caravan that are included in the Warranty Cover and which suffer a defect in manufacture or workmanship. An Authorised Service Centre means either Bailey itself, a Bailey Approved Retailer or a Bailey Approved Service Centre. Any part which is replaced becomes the property of Bailey. Any replacement parts are covered for the unexpired term of the Warranty Cover.

Term

- 2 The initial duration of the Bodyshell Integrity Guarantee is six (6) years extendable to ten (10) years and the duration of the Manufacturer's Warranty is three (3) years extendable to six (6) years, in both cases starting from the original purchase date of the caravan. It is a condition of the warranty that an annual service is performed on the caravan in accordance with the service plan. Failure to comply with this term will invalidate the warranty.
- 3 The unexpired term of the Warranty Cover on your caravan may only be assigned, transferred or novated to subsequent owners with Bailey's consent (not to be unreasonably withheld) and on payment to Bailey of a transfer fee of £35. Full documentary evidence that the caravan has been serviced annually should be provided at the time of assignment, in accordance with the terms and conditions detailed above.

Repairs

- 4 The caravan must undergo a full annual service and inspection, including a moisture survey, carried out, subject to paragraph 5 below, by an Authorised Service Centre. The final annual service in the warranty period must be carried out before the end of that warranty period, but all other annual services may be carried out within six (6) weeks either side of each anniversary of the original purchase date. The original VAT invoices must be retained as proof that these annual inspections have been carried out.
- 5 During the first three (3) years of the Warranty Cover, all annual inspections and repairs must be carried out either by Bailey itself or an approved Bailey Service Centre or Agent. Thereafter, due to the technical nature of an Alu-Tech constructed caravan, annual inspections and repairs may be carried out by any workshop or repair centre approved by the National Caravan Council that has attended Alu-Tech training courses at the Bailey factory.
- 6 Where an annual inspection identifies that repairs to the caravan are necessary, the caravan must be made available for repair within six (6) weeks of the date of inspection for the purpose of carrying out the repair work.
- 7 No repairs, including the fitting of any replacement unit, may be undertaken or commenced under the terms of the Warranty Cover unless prior written authorisation is obtained from Bailey via an authorised Bailey Retailer or Service Centre. No liability will exist with regard to any warranty claims not authorised in this way.
- 8 Bailey reserve the right to examine the caravan before any repairs commence or any replacement part is fitted.

Registration & Use

- 9 The Warranty Registration Form must have been sent to Bailey within six (6) weeks of the original purchase date. It is the responsibility of the Bailey Retailer to forward this information to Bailey. This is part of the terms of trading that that the Bailey Retailer has with Bailey.

WARRANTY



- 10 The caravan shall:
- (a) only be used for its ordinary and intended purpose and shall not be subjected to any treatment or conditions which could reasonably be foreseen to cause or result in damage to the caravan or excessive wear and tear;
 - (b) only be towed by a private car or private 4x4 vehicle; and
 - (c) not be put out to hire, reward or any other commercial use, nor used in any race, competitions or rallies whether timed, official or otherwise.

Exclusions & Liability

- 11 Bailey's liability under this warranty shall be limited to supplying the reasonable costs of labour and materials required for the repair or replacement of faulty parts or components. Bailey shall be entitled to charge for any repair work which is necessitated by virtue of any loss or damage caused by your negligence or default or incurred as a result of any modifications you have made to the caravan. This warranty does not cover repair costs other than labour and materials.
- 12 The Warranty Cover does not include:
- (a) repair or replacement of parts, components, seams or panels which are not part of the original construction of the caravan, or which have been tampered with or undergone unauthorised modifications, or which have been repaired otherwise than by an Authorised Service Centre;
 - (b) parts or components other than those specifically listed in the Bodysell Integrity Guarantee and Manufacturer's Warranty descriptions set out above;
 - (c) general maintenance or components failing due to fair wear and tear or normal deterioration;
 - (d) repairs necessitated by lack of routine or regular maintenance. Particular attention is drawn to the Owner's Manual and Service Handbook supplied with the caravan and any maintenance instructions or notices published from time to time by Bailey relating to the proper care and maintenance of caravans; or
 - (e) structural degradation or other damage caused by water ingress through non-permanently sealed seams or joints (such as, without limitation, around windows, hatches, doors and rooflights), beyond the initial 24 months of the Manufacturer's Warranty.
- 13 No liability will be accepted for:
- (a) damage caused by neglect or abuse, corrosion, intrusion of foreign or deleterious substances, lack of servicing, over-heating, freezing, or the continued use of the caravan after a fault has become evident;
 - (b) any loss or damage caused by parts not covered by this Warranty Cover, including soft furnishings or trim;
 - (c) any accidental or fire damage or any losses incurred by accident or fire; or
 - (d) transport costs to and from point of repair.
- 14 Bailey will only be liable for costs which are incurred as a direct consequence of the event, defect or fault leading to the claim being made under this warranty. No liability will be accepted for any other loss or damage (such as loss of income or revenue, or loss of business or profits), costs, expenses or other claims for compensation howsoever arising which was not reasonably foreseeable by both parties when the caravan was originally purchased. Bailey will not be liable for any loss or damage suffered by third parties, nor for bodily injury not caused by our negligence.
- 15 Nothing in this warranty shall limit in any way our liability: for death or personal injury caused by our negligence; for fraud or fraudulent misrepresentation; or for any matter for which it would be illegal for us to exclude, or attempt to exclude, our liability.
- 16 The purchaser has statutory rights in addition to this warranty and this warranty does not affect those statutory rights.
- 17 This warranty shall be governed by and construed in accordance with the laws of England and the parties irrevocably submit to the non-exclusive jurisdiction of the courts of England.



SPECIFICATIONS

MODEL	BERTHS	INTERNAL BODY LENGTH	SHIPPING LENGTH	OVERALL BODY WIDTH	OVERALL HEIGHT	MAXIMUM HEADROOM	TYRE SIZES	TYRE PRESSURE (P.S./BAR) **
PEGASUS 462	2	4.902m	6.475m	2.28m	2.63m	1.96m	195/70 R14 LI 96N	58 / 4.0
PEGASUS 514	4	5.608m	7.181m	2.28m	2.63m	1.96m	185 R14 LI 104	62 / 4.3
PEGASUS 524	4	5.608m	7.181m	2.28m	2.63m	1.96m	185 R14 LI 104	63 / 4.35
PEGASUS 534	4	5.608m	7.181m	2.28m	2.63m	1.96m	185 R14 LI 104	63 / 4.35
PEGASUS 546	6	5.608m	7.181m	2.28m	2.63m	1.96m	185 R14 LI 104	63 / 4.35
PEGASUS 554	4	5.608m	7.181m	2.28m	2.63m	1.96m	185 R14 LI 104	63 / 4.35
PEGASUS 624	4	6.292m	7.865m	2.28m	2.63m	1.96m	185/65 R14 LI 93N	43 / 3.0



- ▲ The M.T.P.L.M. must not be exceeded. The maximum towing speed at M.T.P.L.M. for all models is 81 m.p.h. (130 k.m.p.h.)
- ▲ The maximum vertical static load for the coupling head or the maximum vertical load on the towing ball specified for the towing vehicle must not be exceeded.

** Figures quoted for when tyre is cold.

Steel wheel rim size: 5 $\frac{1}{2}$ J x 14 H2 ET30, 112mm PCD 5 stud.

Alloy wheel rim size: 6J x 14 H2 ET30, 112mm PCD 5 stud

SPECIFICATIONS



MODEL	MAXIMUM TECHNICAL PERMISSIBLE LADEN MASS	M.R.O.	MASS OF ESSENTIAL HABITATION EQUIPMENT EFFECTS	PAYLOAD ALLOWANCE FOR PERSONAL EQUIPMENT	PAYLOAD ALLOWANCE FOR OPTIONAL EQUIPMENT	TOTAL USER PAYLOAD
PEGASUS 462	1326kg	1137kg	68kg	106kg	15kg	189kg
PEGASUS 514	1466kg	1250kg	68kg	133kg	15kg	216kg
PEGASUS 524	1480kg	1264kg	68kg	133kg	15kg	216kg
PEGASUS 534	1482kg	1266kg	68kg	133kg	15kg	216kg
PEGASUS 546	1497kg	1261kg	68kg	153kg	15kg	236kg
PEGASUS 554	1492kg	1276kg	68kg	133kg	15kg	216kg
PEGASUS 624	1661kg	1438kg	68kg	140kg	15kg	223kg



- ▲ The M.T.P.L.M. must not be exceeded. The maximum towing speed at M.T.P.L.M. for all models is 81 m.p.h. (130 k.m.p.h.)
- ▲ The maximum vertical static load for the coupling head or the maximum vertical load on the towing ball specified for the towing vehicle must not be exceeded.

** Figures quoted for when tyre is cold.

Steel wheel rim size: 5¹/₂J x 14 H2 ET30, 112mm PCD 5 stud.

Alloy wheel rim size: 6J x 14 H2 ET30, 112mm PCD 5 stud



WIRING DIAGRAMS

ROADLIGHT WIRING – PEGASUS

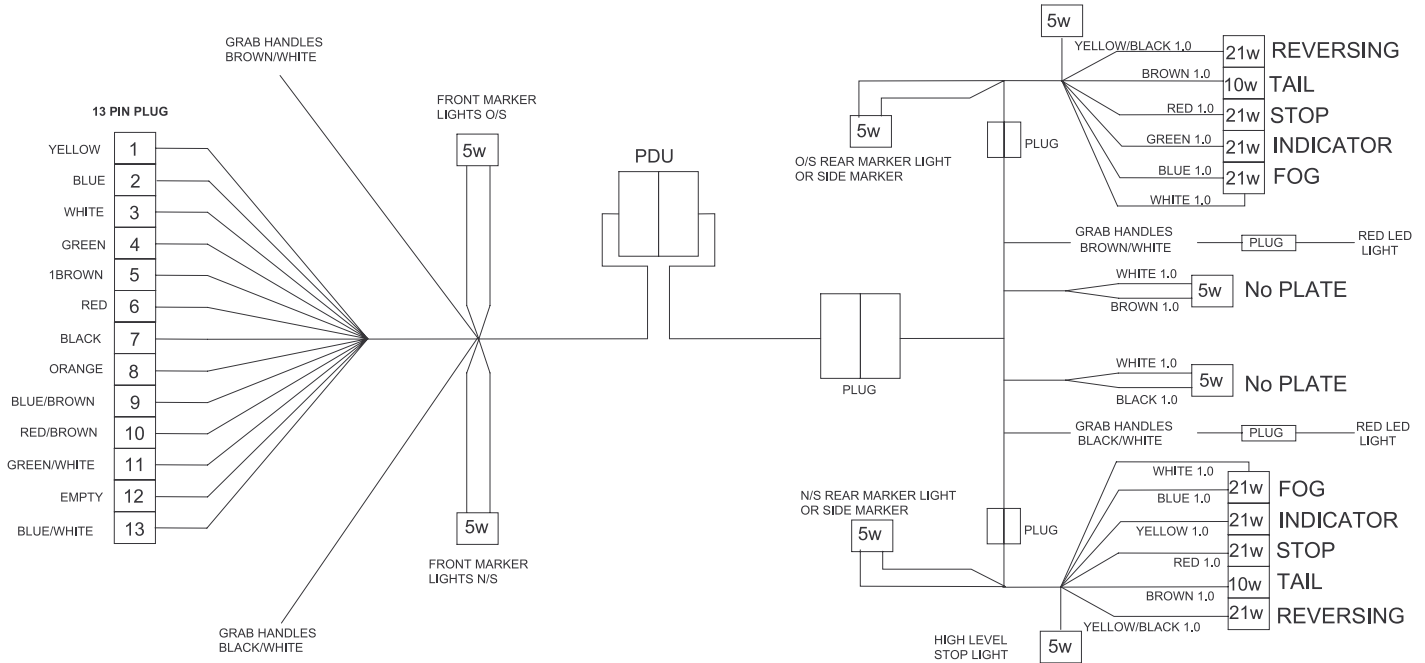

NOTE: ALL CABLE SIZES GIVEN IN MM²

WIRING DIAGRAMS



230 VOLT & 12 VOLT PRIMARY CIRCUIT DIAGRAM - PEGASUS

COLOUR KEY
 O/O-ORANGE/GREEN
 YEL-YELLOW(AUX)
 Y-YELLOW(C/P)
 RD-RED
 WH-WHITE
 BL-BLUE
 RD/O-RED/ORANGE
 O-ORANGE
 BL/RD-BLUE/RED
 G/B-GREEN/BLUE
 G/RD-GREEN/RED
 O/BLK-ORANGE/BLACK
 G/BR-GREEN/BROWN
 B/W-BLACK/WHITE
 G-GREEN
 B/BR-BLUE/BROWN
 G/BK-GREEN/BLACK
 P-PURPLE
 B-BLACK
 O/W-ORANGE/WHITE
 GY-GREY
 Y/B-YELLOW/BLACK

CONNECTIONS FROM 13 PIN PLUG

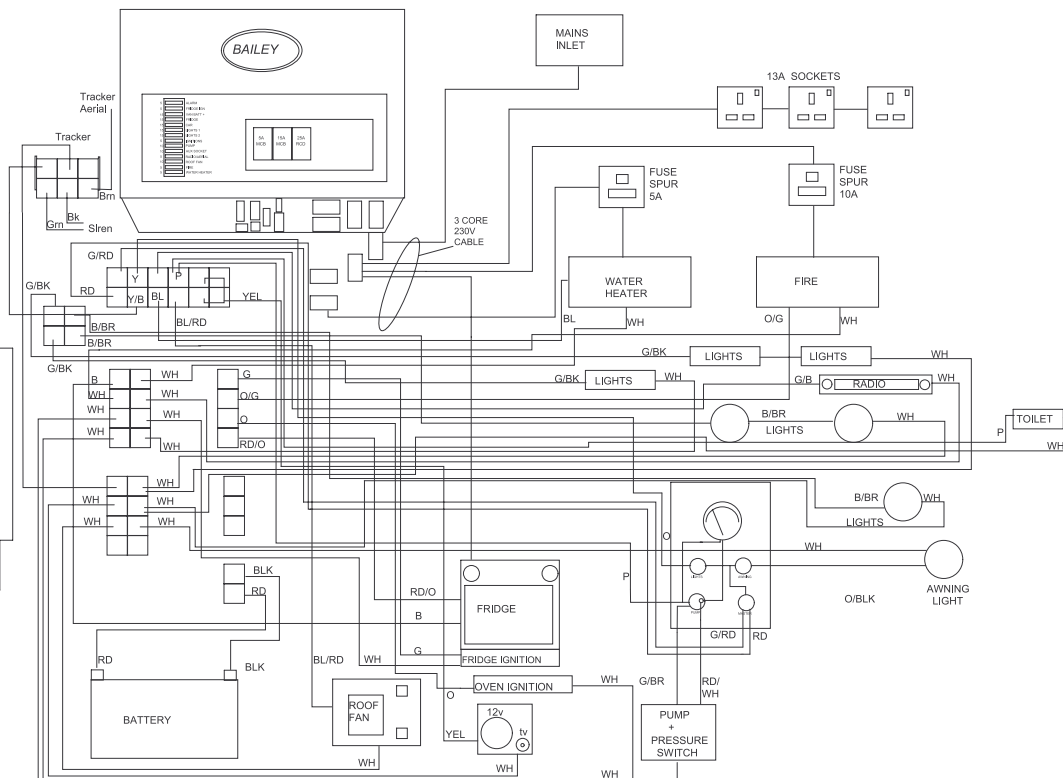
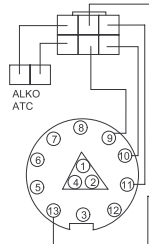



WIRING DIAGRAMS

PEGASUS CONTROL PANEL DIAGRAM

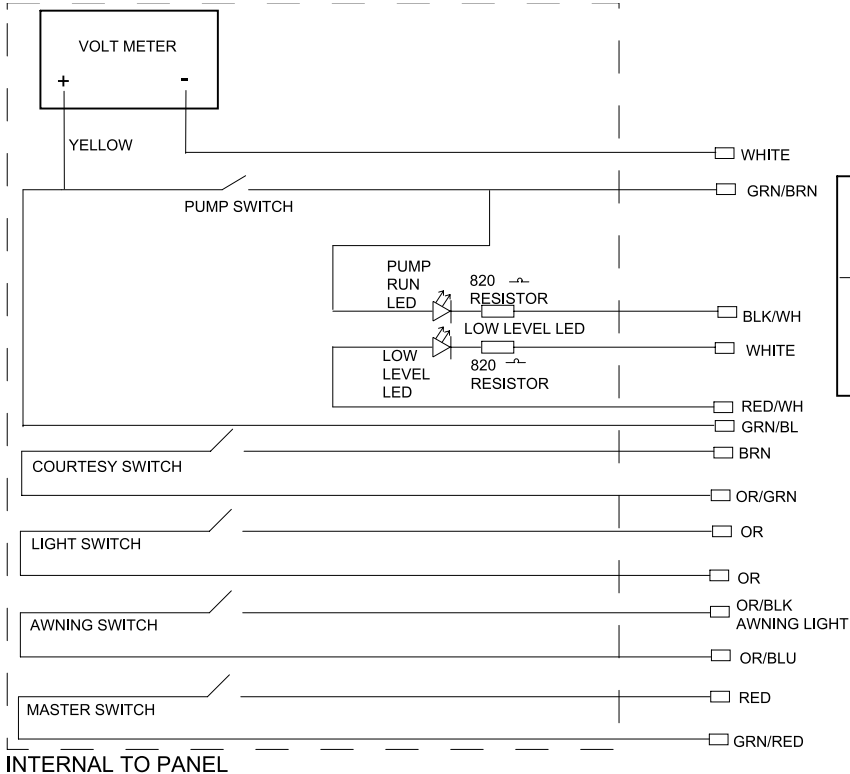

SOCKET VIEWED FROM CABLE ENTRY

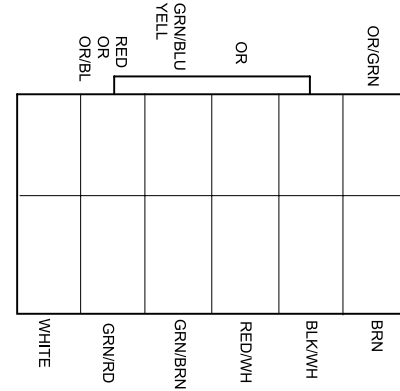

FUSE/MCB SPECIFICATION - PEGASUS

FUSES

Alarm	5 amp (yellow)
Fridge Ign	5 amp (yellow)
Caravan battery	15 amp (blue)
Fridge	15 amp (blue)
Car	15 amp (blue)
Lights 1	15 amp (blue)
Lights 2	15 amp (blue)
Ignitions	5 amp (yellow)
Pump	10 amp (red)
Aux socket	10 amp (red)
Radio/aerial	5 amp (yellow)
Roof fan	10 amp (red)
Fire	5 amp (yellow)
Water heater	5 amp (yellow)
Truma Ultrastore	230V 5 amp cartridge
Refrigerator	230V 3 amp cartridge
Truma Ultraheat	230V 10/13 amp cartridge
Smoke alarm battery	9 volt PP9



BULB, TUBE & FUSE SPECIFICATION - PEGASUS

ROAD LIGHTS

Front and rear grab handles	12 volt	< 1 watt	LED	BCA
Front marker light	12 volt	< 1 watt	LED	Jokon
Side marker light	12 volt	5 watt	Bayonet	Clear
Brake lights (low level)	12 volt	21 watt	Bayonet	Clear
Fog lights	12 volt	21 watt	Bayonet	Clear
Indicator	12 volt	21 watt	Bayonet	Orange
Number plate light	12 volt	10 watt	Festoon	Clear
High level brake light	12 volt	21 watt	Bayonet	Clear
Reversing light	12 volt	21 watt	Bayonet	Clear

INTERIOR LIGHTS

Fluorescent lights	12 volt	8 watt		
LED spotlights	12 volt	< 1 watt	LED	Sargent
Double locker LED	12 volt	< 2 watt	LED	BCA
Single locker LED	12 volt	< 1 watt	LED	BCA
Ciro ceiling light	12 volt	2 x 10 watt	G4	Ring
T/C and vanity downlighter	12 volt	10 watt	G4	Ring
Awning light	12 volt	< 1 watt	LED	BCA



AWNING SIZES

The following are the ground to ground dimensions through the awning channel. These dimensions are issued as a guideline only, please refer to your dealer for the correct awning size to suit your particular caravan.

PEGASUS	462	968 cms
	514	1039 cms
	524	1039 cms
	534	1039 cms
	546	1039 cms
	554	1039 cms
	624	1113 cm



PEGASUS SERVICE SCHEDULE

In order to validate the factory backed warranty package, your caravan must be serviced by an approved Bailey Service Centre every 12 months (or within 6 weeks of each anniversary of purchase) in accordance with the NCC recommended service schedule.

A full listing of the current Approved Bailey Centres can be found on the Retailer Network pages of our web site @ www.bailey-caravans.co.uk. Alternatively please contact our Customer Helpline on 0117-3052939 for details of your local service agent.

ALU-TECH CONSTRUCTION SERVICE SCHEDULE

All products manufactured using the Alu-Tech Construction System have a bespoke service plan which is as follows:-

Year One - Full Approved Workshop Scheme Service including moisture survey @ £150 + VAT & Parts.

Year Two - Full Approved Workshop Scheme Service including moisture survey @ £250 + VAT & Parts.

Year Three - Full Approved Workshop Scheme Service including moisture survey and security check of body shell fixing clamps @ £350 + VAT & Parts.

Year Four onwards - Full Approved Workshop Scheme Service including moisture survey @ standard Service Centre price tariff.

Warning: In no circumstances should the body shell fixings be tampered with or adjusted by the caravan owner. In instances where this has occurred the warranty will be automatically invalidated.

STANDARD MOISTURE SURVEY FOR ALU-TECH CONSTRUCTION CARAVANS

The following moisture survey must be carried out using a calibrated moisture meter every 12 months by an Approved Bailey Service Centre.

Readings should be taken on the floor section of the caravan in positions where the holes created by the meter's probe are not visible, i.e. behind seals, in bedboxes or in cupboard bases. It is important to make sure that the probes are free of moisture and the surface of the floor is free from condensation.

Readings below 20% are considered acceptable. Readings greater than 20% will identify areas needing further investigation and possibly remedial work.

All other parts of the body of the Alu-Tech caravan should be checked visually for moisture ingress.

THERMAL INSULATION GRADING

All Bailey Alu-Tech construction caravans are manufactured and approved by the National Caravan Council to EN1645-1 thermal insulation and heating classification Grade III. This has been approved using the caravan space heater using gas as the heating method.

Grade III is classified as being able to achieve an average temperature difference of 35 degrees centigrade between inside and outside the caravan when the exterior temperature is -15 degrees centigrade.

NOTES



