

# TyrePal Tyre Pressure Monitoring System with compact sensors TC215B User Manual



**TyrePal**  
A WSL COMPANY  
TYRE PRESSURE MONITORING SYSTEMS

**Innovative safety solutions for your peace of mind**

*Wheel Solutions Limited, Unit 2 Upper Keys Business Park, Keys Park Road, Hednesford,*

*Cannock, Staffordshire, WS12 2GE, United Kingdom*

*Tel: +44 (0)1543 870 170 e-mail: [enquiries@tyrepal.co.uk](mailto:enquiries@tyrepal.co.uk) [www.tyrepal.co.uk](http://www.tyrepal.co.uk)*

# CONTENTS

1. SYSTEM COMPONENTS .....	3
1.1 Monitor and accessories.....	3
1.2 Sensors .....	3
1.3 Optional components.....	3
1.4 Monitor layout and controls.....	4
1.5 Screen icons .....	4
2. IMPORTANT SAFETY NOTES .....	4
3. BEFORE INSTALLATION.....	5
3.1 Wheel balancing.....	5
3.2 Battery charging.....	5
3.3 Sensors and wheel positions .....	5
4. INSTALLATION.....	6
4.1 Install and register the sensors .....	6
4.2 Deleting a sensor setting .....	6
4.3 Lock the sensors.....	6
4.4 Test for leaks .....	6
4.5 Set units and alert levels.....	7
4.6 Install the monitor.....	8
4.7 Connect the power .....	9
5. OPERATION .....	9
5.1 Sleep mode.....	9
5.2 Alerts.....	9
5.3 Backlight.....	11
5.4 Connecting and disconnecting a trailer.....	11
5.5 Replacing sensor batteries .....	11
6. TESTING THE SETUP.....	12
7. SIGNAL REPEATER (OPTIONAL EQUIPMENT).....	12
8. TROUBLESHOOTING AND ADDITIONAL INFORMATION.....	12
9. SPARES, SERVICE AND WARRANTY.....	13
10. SPECIFICATION SUMMARY .....	13

*Wheel Solutions Limited, Unit 2 Upper Keys Business Park, Keys Park Road, Hednesford,*

*Cannock, Staffordshire, WS12 2GE, United Kingdom*

*Tel: +44 (0)1543 870 170 e-mail: [enquiries@tyrepal.co.uk](mailto:enquiries@tyrepal.co.uk) [www.tyrepal.co.uk](http://www.tyrepal.co.uk)*

# 1. SYSTEM COMPONENTS

## 1.1 Monitor and accessories

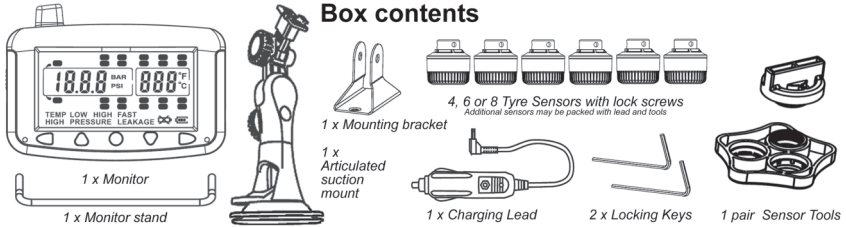

## 1.2 Sensors

The system can be supplied with TCSB compact sensors that can be used for tyre pressures up to 99psi / 6.8 bar. The monitor is also compatible with TCSE sensors for higher pressures (up to 188psi / 13 bar) and also TPMS INT 01 internal sensors fitted to TyrePal TPMS Ready systems. If different sensors are used, the operation of the monitor may not be exactly as described in this manual.

The sensors have integral locking screws which can be used to prevent casual theft.

The box may also contain some spare O-rings that can be used as replacement seals when the sensor batteries are replaced.

## 1.3 Optional components

The system may be supplied with optional parts such as a Signal Repeater. This is used to extend the range of the sensor signals and can also store trailer settings to simplify exchanging trailers in a fleet.

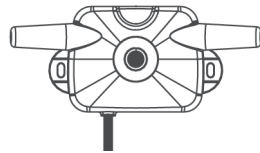

## 1.4 Monitor layout and controls

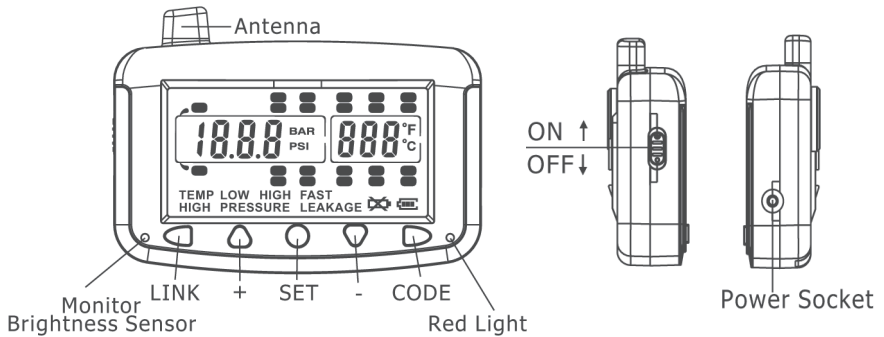

## 1.5 Screen icons

Tyre position icon



Monitor battery icon



(fully charged)



(requires charging)

Sensor low battery icon



## 2. IMPORTANT SAFETY NOTES

The TyrePal system can help you maintain tyre pressures for safety, fuel economy, tyre life and environmental impact.

It is your responsibility to ensure that it is suitable for your particular vehicle and that it is working correctly and properly maintained. Check the sensors and valve stems regularly, as some road salts can cause corrosion.

**The system does not replace the need to carry out regular checks on the condition and wear of the tyres.**

Keep the small parts and especially the batteries out of the reach of children. If a battery is swallowed, consult a doctor. Do not hold a battery with metallic tweezers as it will cause a short circuit and may lead to burning or explosion of the battery.

### 3. BEFORE INSTALLATION

Before installing the system, ensure that it is suitable for your vehicle.

- Check that the operating pressure of your tyres is within the range of the system. i.e. 0-99psi (0-6.8 bar)
- Check that tyre valve stems are in good condition before fitting the sensors. We do not recommend using the system with aluminium valve stems. (Because of the possibility of corrosion between dissimilar metals).
- Do not fit sensors to tyres that have been treated with internal tyre sealant. The sealant may damage the sensor or impair its action.
- To avoid danger of damage to the sensors, check that sensor valve caps will remain within the outside profile of the tyres when fitted.

If the distance from the rear wheels to the monitor is greater than about 7 metres, we recommend the use of a TyrePal Signal Repeater to increase the range of the sensors and improve the stability of the system

#### 3.1 Wheel balancing

The weight of the sensors is within the tolerance achieved for wheel balancing, so there is usually no need for the wheels to be rebalanced after installing the system. If vibration is felt when driving at speed after fitting the system, the wheels must be rebalanced.

#### 3.2 Battery charging

The monitor is powered from an internal rechargeable battery that may need to be charged before first use. A full charge will last for about 60 hours operation. It can be charged from the vehicle 12-24V supply using the supplied cigarette lighter lead.

#### 3.3 Sensors and wheel positions

Sensors are interchangeable and can be registered to any of the 22 possible wheel positions. Once sensors are registered, the display only shows data from the registered positions. We recommend that you label each sensor, with the supplied labels to identify its position and record the positions below as to which tyre positions you wish to monitor:

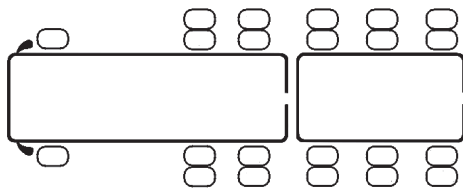

*Wheel Solutions Limited, Unit 2 Upper Keys Business Park, Keys Park Road, Hednesford,*

*Cannock, Staffordshire, WS12 2GE, United Kingdom*

*Tel: +44 (0)1543 870 170 e-mail: [enquiries@tyrepal.co.uk](mailto:enquiries@tyrepal.co.uk) [www.tyrepal.co.uk](http://www.tyrepal.co.uk)*

## 4. INSTALLATION

### 4.1 Install and register the sensors

The following procedure registers the sensors as they are installed.

1. In standby mode, press and hold the **CODE** button for 3 seconds. Release it after the beep to enter coding mode. A flashing tyre icon is displayed. If no sensor is registered to this position, the letters FFF FFF are shown. If a sensor is already registered, the sensor ID is shown.
2. To select the desired tyre position to be monitored, press the **+** or **-** button to scroll through to the desired position.
3. Screw the sensor onto the tyre valve. As it senses the air pressure, the sensor sends its ID code to the monitor. The monitor beeps and stores the tyre position with that sensor ID. If it does not register within a few seconds, unscrew the sensor and try again.
4. Press **+** or **-** buttons to select the other tyres and repeat for all the tyres that are to be monitored.
5. When all sensors are registered, press and hold the **CODE** button to exit.

### 4.2 Deleting a sensor setting

If you need to delete a setting, whilst in standby mode press and hold the CODE button for 3 seconds, release it after the beep to enter the coding mode. A flashing tyre icon and ID code are displayed. Use the **+** or **-** buttons to select the tyre position then press and hold the SET button for 3 seconds. A double beep confirms the ID has been deleted.

Note: If a sensor is coded twice to the same monitor, the previous setting will be deleted automatically.

### 4.3 Lock the sensors

For added security, the locking screw in the sensor can be tightened onto the valve stem using the hex key, but do not over tighten. If it is difficult to reach, take the sensor off and insert the locking screw into a different hole.

Keep the hex key in a safe place as it is needed to remove the sensor.

### 4.4 Test for leaks

When the sensors have been installed, test for leaks by brushing a little detergent and water on the valve stems.

If bubbles appear, release the locking screw and re-tighten the sensor.

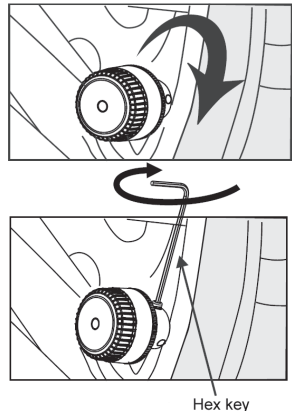

*Wheel Solutions Limited, Unit 2 Upper Keys Business Park, Keys Park Road, Hednesford,*

*Cannock, Staffordshire, WS12 2GE, United Kingdom*

*Tel: +44 (0)1543 870 170 e-mail: [enquiries@tyrepal.co.uk](mailto:enquiries@tyrepal.co.uk) [www.tyrepal.co.uk](http://www.tyrepal.co.uk)*

#### 4.5 Set units of pressure and alert levels

Pressure units can be set to display in psi or bar, and temperature in °C or °F. Pressure alerts are set individually for each of the three axles on the towing vehicle (tractor) while the trailer settings apply to all axles on the trailer. We recommend that the high pressure alert is set at 20% above the manufacturer's recommended pressure, and the low alert 15% below. The temperature alert level applies to all tyres. The factory set default is 70°C and we recommend that this is not changed.

1. In standby mode, press and hold the SET button for 3 seconds. Release after the beep. Press the SET button repeatedly to scroll through the different settings and press the + or – buttons to adjust the setting as follows:
2. Pressure units: while the PSI or BAR icon is flashing, press the + or – button to select the desired units. Then press SET to move on to set temperature units.
3. Temperature units: while the °C or °F is flashing, press the + or – buttons to select and press SET again to move on to set the high pressure alert level for the first axle.
4. First axle pressure alert levels: Press + or – to adjust the high pressure setting, then press SET to move on to set the low pressure alert for this axle.

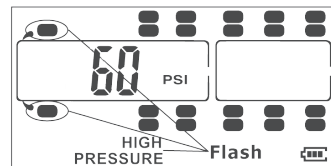
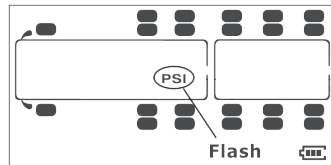

Note that the system will not allow the high pressure alert to be less than the low pressure alert level. The factory set low pressure level is set to 30psi, so if you want the high pressure alert level below 30psi, you must set the low pressure alert levels first, then cycle through again to set the high pressure alerts.

5. Continue to cycle through high and low pressure settings for the three axles on the tractor unit and all three axles on the trailer.
6. **High temperature alert for all wheels:** Press + or – to adjust the setting as required. The factory setting of 70°C is a minimum and is suitable for most applications.
7. Press and hold the **SET** button for three seconds to save the settings and exit the settings mode. If no action is taken for 1 minute, the system will return to standby mode without making any changes.

The alert levels can be adjusted at any time using this procedure, for example if different pressures are required when not towing a trailer. The new settings take immediate effect.

*Wheel Solutions Limited, Unit 2 Upper Keys Business Park, Keys Park Road, Hednesford,*

*Cannock, Staffordshire, WS12 2GE, United Kingdom*

*Tel: +44 (0)1543 870 170 e-mail: [enquiries@tyrepal.co.uk](mailto:enquiries@tyrepal.co.uk) [www.tyrepal.co.uk](http://www.tyrepal.co.uk)*

#### 4.6 Install the monitor

Various fixing options are available for the monitor. Make sure it does not obstruct the driver's view when installed.

Click the monitor into position. If required the monitor can be removed by unclipping it from the mount.

##### **Windscreen mount:**

Clip the monitor to the holder, moisten the suction pad and press it to the windscreen. Lower the lever to secure the pad to the windscreen.

To remove it, lift the lever to break the suction, or unclip the monitor from the holder.

##### **Free standing:**

Fit the monitor stand in the holes in the back of the monitor and position it where it can be seen. Note that the stand is a tight fit in the holes.

##### **Screw mount:**

The monitor mount can be permanently fixed to the vehicle with the bracket. To use the screw mounting option, dismantle the suction holder and re-assemble it

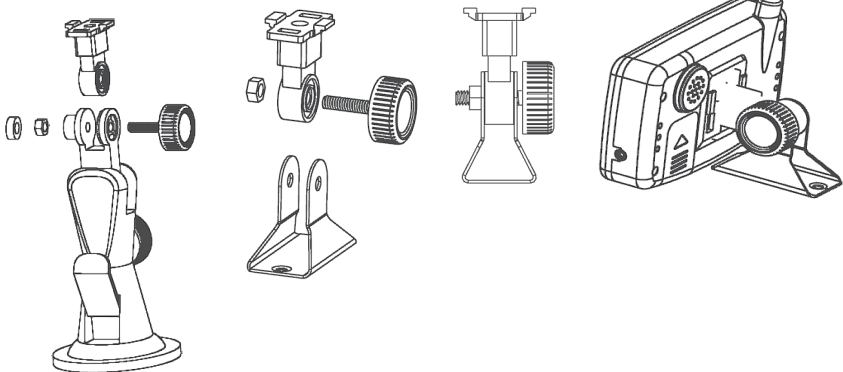
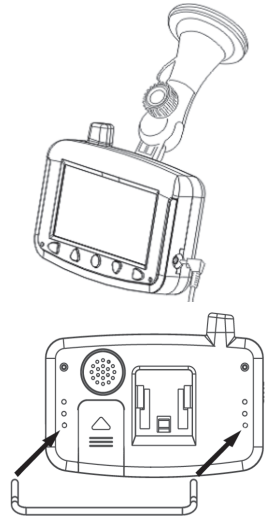

#### 4.7 Connect the power

Connect the monitor to the vehicle power supply (12V or 24V) via the power adapter to charge the battery. A full charge will last for about 60 hours of operation.

*Wheel Solutions Limited, Unit 2 Upper Keys Business Park, Keys Park Road, Hednesford,*

*Cannock, Staffordshire, WS12 2GE, United Kingdom*

*Tel: +44 (0)1543 870 170 e-mail: [enquiries@tyrepal.co.uk](mailto:enquiries@tyrepal.co.uk) [www.tyrepal.co.uk](http://www.tyrepal.co.uk)*



## 5. Operation

In normal operation the monitor continuously scrolls through and displays the pressure and temperature of the tyres one by one. You can manually scroll through to any particular tyre by using the + or - buttons. The system is accurate to +/- 1.5psi (0.1bar ), so a difference of one or two psi between the tyres can safely be ignored.

The sensors check the pressure and temperature every few seconds while the vehicle is moving. If the pressure is falling, data is transmitted to the monitor immediately, but if the pressure is steady, data is transmitted only every five minutes. This is to reduce power consumption and extend the life of the sensor batteries.

### 5.1 Sleep mode

The monitor has a built-in motion sensor that shuts it down into a sleep mode after about ten minutes of no movement so it does not normally need to be turned off. Any vibration such as opening the vehicle door wakes it up again. If the vehicle is to be unused for some time, we recommend turning the monitor off to prevent battery drain.

The sensors supplied with this model also have a sleep mode, and when the vehicle has been stationary for several minutes, they stop transmitting to save battery power. When the monitor wakes (after a door is opened for example), the display will scroll through the monitored tyres, but no pressures or temperatures will be shown. It will also chirp at each monitored position. However, once you begin to drive, within a few hundred metres, the sensors will wake and the monitor will display the pressures and temperatures and the chirping will cease.

### 5.2 Alerts

If a sensor battery is low, or if a signal is not received from a sensor for a period of 60 minutes, an alert is issued.

If there is a leak or if any tyre is outside the pre-defined values, it gives an alert:

Press any button to switch the alarm off. The red light will continue to flash until the problem is corrected.

The following messages may appear: HIGH PRESSURE, LOW PRESSURE, HIGH TEMP, FAST LEAKAGE

- An audible alarm
- A flashing red light
- A flashing tyre icon that identifies the tyre
- A description of the problem

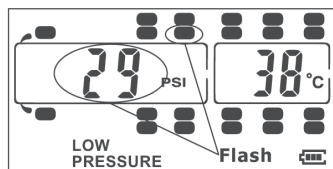

*Wheel Solutions Limited, Unit 2 Upper Keys Business Park, Keys Park Road, Hednesford,*

*Cannock, Staffordshire, WS12 2GE, United Kingdom*

*Tel: +44 (0)1543 870 170 e-mail: [enquiries@tyrepal.co.uk](mailto:enquiries@tyrepal.co.uk) [www.tyrepal.co.uk](http://www.tyrepal.co.uk)*

The **FAST LEAKAGE** alert is a serious situation that could rapidly affect the stability of the vehicle. If this alert appears it means that there has been a loss of 0.14bar/2psi within 1 minute , so you should pull over and investigate immediately.

The **HIGH TEMPERATURE** alert shows that the tyre is overheating.

**If not corrected, this can cause permanent damage to the sidewall of the tyre and will potentially lead to a blowout or a fire.**

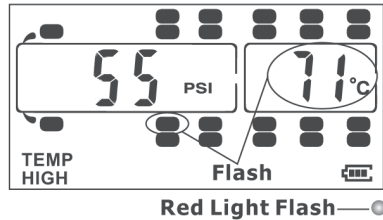

#### Sensor battery alert:

When a sensor battery needs replacing, a low sensor battery icon is shown, and the appropriate tyre icon flashes.



#### Monitor battery alert:



Fully  
charged



Requires  
charging

When fully charged, the monitor battery will operate for 60 hours. When it needs charging, the monitor battery icon changes from full to part full. Connect the monitor to the vehicle power supply and the icon becomes animated while charging. It is not harmed by partial charging and does not have to be fully discharged before recharging.

### 5.3 Backlight

The backlight turns on automatically when it gets dark if the vehicle is in motion. It turns off when it is light or when the monitor is in sleep mode. Press any button to turn the backlight on manually. To turn it off, press and hold the **+** button for 3 seconds.

### 5.4 Connecting and disconnecting a trailer

When the trailer is not connected to the vehicle, press the **LINK** and **-** buttons at the same time. Trailer monitoring stops and the trailer tyre icons are removed from the display. When the trailer is reconnected, press **LINK** and **+** buttons to display the trailer.

If you drive away from the trailer without unlinking the monitor, it may continue to show the last measured trailer tyre data for a period of time. After about 60 minutes it will stop displaying data for the trailer tyres and will give a short beep each time the trailer tyre position is accessed.

### 5.5 Replacing sensor batteries

When the sensor low battery icon is showing and a corresponding tyre icon is flashing, the sensor battery needs to be replaced. The battery is a CR1632 lithium cell, available from many stores or from [www.tyrepal.co.uk](http://www.tyrepal.co.uk)

1. Use the hex key to slacken the locking screw, then take the sensor off the tyre valve, but do not completely remove the locking screw.
2. Use the sensor tools to remove the battery cover from the sensor and expose the battery.
3. Replace the CR1632 battery making sure the positive **+** side is upwards and that it goes inside the metal cage, not on top of it.
4. Check that the waterproof rubber seal is in position and replace the battery cover, using the sensor tool to replace the cover.

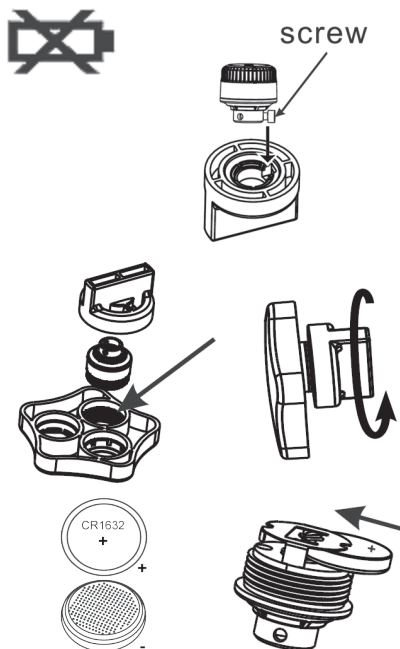

Wheel Solutions Limited, Unit 2 Upper Keys Business Park, Keys Park Road, Hednesford,

Cannock, Staffordshire, WS12 2GE, United Kingdom

Tel: +44 (0)1543 870 170 e-mail: [enquiries@tyrepal.co.uk](mailto:enquiries@tyrepal.co.uk) [www.tyrepal.co.uk](http://www.tyrepal.co.uk)

## 6. TESTING THE SETUP

To test the transmission range on first installation, position the monitor in the driver's cab and unscrew the furthest sensor. The system should produce an alert for that tyre position, within about 10 seconds. Tighten the sensor and the alert should stop.

This test must be carried out within a few minutes of the installation or after the vehicle has been in motion, as the sensor will not transmit if it is in the sleep mode. Simply moving the sensor about or unscrewing it will not reactivate it from the sleep mode.

If the alert is not given, the sensor may be out of range. The sensors have a transmission range of about 20 metres in open air, but in practice, screening by the vehicle chassis and bodywork reduce the working distance to about 7 metres. This can be increased by using the optional Signal Repeater.

## 7. SIGNAL REPEATER (OPTIONAL EQUIPMENT)

The Signal Repeater can either be used to boost sensor signals from a single trailer, or in a fleet application, it can simplify exchanging trailers by storing the trailer settings. In this case, one is fitted to each trailer.

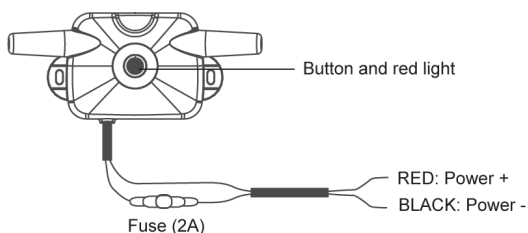

For rigid vehicles like motorhomes and buses, position the Signal Repeater near the rear of the vehicle. For caravans and trailers, position it near the front of the trailer, and with the antenna clear of metallic parts.

Fix it in place with screws through the lugs and connect it to the vehicle power supply (12 to 24V) with the red wire to + positive, and the black to - negative. The cable has an in-line 2A fuse.

## 8. TROUBLESHOOTING AND ADDITIONAL INFORMATION

Additional information about the system, including troubleshooting and advice on managing tyre pressures is provided on the TyrePal web site, [www.tyrepal.co.uk](http://www.tyrepal.co.uk), where it is regularly updated.

*Wheel Solutions Limited, Unit 2 Upper Keys Business Park, Keys Park Road, Hednesford,*

*Cannock, Staffordshire, WS12 2GE, United Kingdom*

*Tel: +44 (0)1543 870 170 e-mail: [enquiries@tyrepal.co.uk](mailto:enquiries@tyrepal.co.uk) [www.tyrepal.co.uk](http://www.tyrepal.co.uk)*

## 9. SPARES, SERVICE AND WARRANTY

Spare parts including batteries and replacement sensors are available to purchase from the TyrePal web site.

Please register your guarantee by completing details on our web site.

The system is warranted to be free from manufacturing defects and is guaranteed for a period of twelve months from date of purchase. There are no user-serviceable parts inside the monitor and if internal parts have been tampered with, the warranty may be void. The warranty does not affect your statutory rights.

## 10. SPECIFICATION SUMMARY

Specification is subject to change without notice.

### **Monitor**

Dimensions	115 x 73 x 27mm, weight 132g.
Power	Powered by internal lithium battery recharged from vehicle power supply. Automatically shuts down when not in use and reactivates as vehicle is used. Charger input 12 to 24V dc. Battery life is approximately 60 hours per charge.
Display	Clear LCD screen with automatic backlight. View size 80 x 40mm. Continuously cycles through all wheel positions and displays pressure and temperature for each tyre. Additional detail is displayed as required.
Alerts	Bright red flashing LED, plus audible alarm. Audible alarm can be silenced by pressing any button. Distinct alerts are given for the following conditions: Fast leakage (puncture etc) Pressure below user-set threshold Pressure above user-set threshold Temperature above user-set threshold (potential blowout) Warnings are also given if the sensor signal is lost, if a sensor battery is low or when the monitor battery needs recharging.
Units	User selected. Pressure: PSI or bar, Temperature: °C or °F

*Wheel Solutions Limited, Unit 2 Upper Keys Business Park, Keys Park Road, Hednesford,*

*Cannock, Staffordshire, WS12 2GE, United Kingdom*

*Tel: +44 (0)1543 870 170 e-mail: [enquiries@tyrepal.co.uk](mailto:enquiries@tyrepal.co.uk) [www.tyrepal.co.uk](http://www.tyrepal.co.uk)*

## ***Sensors***

Dimensions	Dimensions: 20.5 x 20.5mm (length x diameter). When fitted, they extend approx. 12mm beyond the length of the tyre valve. Weight 12g.
Power	Replaceable CR1632 cell, expected life up to 2 years
Pressure	0 to 99psi +/-1.5psi (0 to 6.8 bar +/- 0.1bar)
Temperature	-40°C to 80°C ±3°C
Transmission	433.92MHz, power <10dBm
Range	Typically circa 7m in vehicle when screened by bodywork etc. Range can be extended with a Signal Repeater.

*Wheel Solutions Limited, Unit 2 Upper Keys Business Park, Keys Park Road, Hednesford,*

*Cannock, Staffordshire, WS12 2GE, United Kingdom*

*Tel: +44 (0)1543 870 170 e-mail: [enquiries@tyrepal.co.uk](mailto:enquiries@tyrepal.co.uk) [www.tyrepal.co.uk](http://www.tyrepal.co.uk)*