



GO WITH  
THE NATION'S  
FAVOURITE



## Caravan Owners Manual

October 2022



ALICANTO GRANDE



PEGASUS  
GRANDE SE



UNICORN



PHOENIX



DISCOVERY

WELCOME TO  
THE NATION'S  
FAVOURITE





## Welcome to Bailey, The Nation's Favourite

We've been proudly hitting the road for over 75 years. Along the way we've built hundreds of thousands of Bailey caravans and motorhomes, each of them with one thing in mind; creating the perfect holiday.

So, no matter which of our models you have chosen for your home away from home, comfort, convenience and adventure are built into every one.

This manual contains everything you need to know on how to operate your caravan and is also available in a digital format at [baileyofbristol.co.uk](http://baileyofbristol.co.uk).

**GO BAILEY!**

We can't wait to see you out there.

Model: \_\_\_\_\_

Vehicle Identification number V.I.N: \_\_\_\_\_  
(Located on the exterior windows and chassis)

Owner's name: \_\_\_\_\_

Address: \_\_\_\_\_  
\_\_\_\_\_  
\_\_\_\_\_  
\_\_\_\_\_  
\_\_\_\_\_

Telephone number: \_\_\_\_\_

Habitation key number: \_\_\_\_\_

Retailer's name: \_\_\_\_\_

Retailer's address: \_\_\_\_\_  
\_\_\_\_\_  
\_\_\_\_\_  
\_\_\_\_\_  
\_\_\_\_\_

Telephone Number: \_\_\_\_\_

MTPLM: \_\_\_\_\_

Caravan Height: \_\_\_\_\_

Caravan Length: \_\_\_\_\_

Caravan Width: \_\_\_\_\_



Free glossy monthly magazine

50% off selected sites mid-week and more



Fantastic ferry fares

# The Caravan and Motorhome Club There's no better value in touring



Save each night on pitch fees



Enjoy access to over 200 UK sites and 2,500 certificated locations



FREE technical help & advice

Discover our many sites on historic estates like Longleat



Exclusive member offers including M6 toll savings



Club Together our online community chat, interact, ask, review

Discover an unrivalled choice of sites and thousands of exclusive destinations, huge savings on everything from new cars and great days out to restaurant meals and show tickets plus a whole host of exclusive services and tailored insurance products.



What are you waiting for? Join today  
[www.caravanclub.co.uk](http://www.caravanclub.co.uk) or call 01342 318 813

## CONTENTS

**INTRODUCTION**

Introduction	11
--------------	----

**STATEMENT OF CONFORMITY**

Statement of Conformity	12
-------------------------	----

**WARRANTY**

Touring Caravan Warranty Cover	13
6 Year Bodyshell Integrity Warranty	13
Warranty Extension	13
3 Year Manufacturer's Warranty	13
Warranty Extension	14
Customer Support	14
Terms and Conditions	14
Cover	14
Term	14
Repairs	14
Registration and Use	15
Exclusions and Liability	15
Warranty Registration	16

**CENTRAL REGISTRATION AND IDENTIFICATION SCHEME (CRIS)**

CRIS Registrations:	17
---------------------	----

**COUNTRY AND COASTAL CODE**

Code of Conduct	18
Arrivals	18
Vehicle Movement	18
Use of Site	18
Cautions	18
Noise	18
Dogs and Pets	18
Fire Precautions	18
Awnings and Tents	18
Departure	18
Handbook	19
Environment	19
The Country Code	19
The Coastal Code	19
Roof Loading	19
Safety and Security	19
Children	19
Fire Extinguishers	20
In Case of Fire	20
Ventilation and Condensation	20
Petrol and Diesel Fumes	20
Original Equipment Appliances	20
Portable Appliances	20
Modifications	20

**CARAVAN AND TOW VEHICLE**

Caravan and Towing Vehicle Terms	21
Kerb Weight of Towing Vehicle	21
Caravan to Towing Vehicle Weight Ratio	22
Towing Vehicle's Rear Suspension	22
Recommended Towball Height	22
Secondary Braking Cable	22
Loading and Distribution of Weight	23
Hitching Up	24
Hitching the Caravan to the Tow Vehicle	24

**TOWING**

Speed Limits	26
Pulling Away	26
Caravan Handling	26
Reversing	26
Motorway Driving	26
Mirrors	26
Snaking	26
Stabilisers	27
Road Lighting	27
13 Pin Plug	27

**UNHITCHING**

Levelling the Caravan	28
-----------------------	----

**WHEELS AND TYRES**

Tyres	29
Wear and Damage	29
Wheel, Tyre and Bolt Safety Fitment	29
Tyre Pressures	29
Wheels	30
Spare wheel	30

**SPARE WHEEL CARRIER**

To lower the Spare Wheel	31
TPMS Tyre Pressure Monitoring	31

**THE AL-KO CARAVAN CHASSIS (AKS 3004)**

Operating Instructions	32
Coupling	32
Stabiliser Unit	33
Uncoupling	33
Manoeuvring Operation	34
Noises While Driving	34
Remedial Action	34
Storing	34
Towing Ball	34
Overrunning Device	35
Jockey Wheel	35
Brake Linkage	35
Corner Steadies	35
Braking System Adjustment	35



Chassis Lubrication Points	37
AL-KO ATC Trailer Control System	37
Operating Instructions	37
Spare Parts	37
Independent Suspension	38
Coupling Head	38

### TRACKER MONITOR

Operating Instructions	39
General Questions	39

### WATER SYSTEMS: WITHOUT AN ON-BOARD WATER TANK

Water Supply	41
Drain Valve	41
Setup	41
Removing the Pump	42

### WATER SYSTEMS: WITH AN ON-BOARD WATER TANK

Water Supply	43
Filling the On-board Tank	43
Internal Supply	43
Tank Drain Operation	44
Draining and Winterization Procedure	44
Initial Setup	44
Sterilising	44
Water System Troubleshooting	45
Adjusting your Pressure Switch	46

### THE GAS SYSTEM

General information	47
Types of gas	47
The Regulator	47
Changing Gas Cylinder	48
Gas Safety Advice	48
Gas Leaks	48
Ventilation	49
Gas BBQ Point	49

### THE ELECTRICAL SYSTEM-230v

Instructions for Electricity Supply	50
Upon Arrival at Caravan Site	50
Upon Leaving Caravan Site	50
Overseas Connections	50
Mains Unit	50

### THE ELECTRICAL SYSTEM- 12v

Battery Box Connections	52
-------------------------	----

### CONTROL PANELS

CBE Control Panels	53
Vegas Control Panels	54

### STATUS 570 ANTENNA

Travelling	55
Operating	55
DAB and FM Radio Operation	55
Gain Control	55
LED Light	55
Short Hook Up: Test 1	55
Short Hook Up: Test 2	56
Antenna Dome Coaxial Cable	56

### SOLAR DUAL BATTERY CHARGER SD C 12

Operating Instructions	57
Function	57
Charging Process	57
Boost Phase	57
Float Phase	57
Device Elements	57
Battery Type	58
Overvoltage Protection	58
Overvoltage Limit	58
Safety Instructions	58
Function Display / Troubleshooting	59
Repairs	59

### HEATING SYSTEMS (ALDE)

Introduction	60
Safety Features	60
Use of the heating system	60
Winter and sub-zero temperatures	60
External factors that may affect the heating system	61
Glycol liquid in the heating system	61
Convection	61
Use of the water heater	61
Care and maintenance	62
Replacing the air cushion	62
Emptying of water heater and water pipes	62
Refill the heating system with glycol fluid	62
Bleeding of the heating system	62
Air lock	63
Operation on electricity	63
Operation on LPG	64
Troubleshooting	64
Service information & reset	65
Warranty	65

**ALDE CONTROL PANEL**

Quick start guide	66
Status Screen	66
Main Menu	67
Set the desired temperature	67
Hot Water	67
Energy sources	68
Heating with electricity	68
Heating with gas	68
High Altitude mode	68
Settings menu	69
Error messages	70
Operating messages	71
Battery Backup	71

**TRUMA COMBI**

COMBI E Series	72
Function Description	72
Heating and Hot Water Mode	72
Hot Water Mode (Filled Boiler)	73
Operating Instructions	73
Room Thermostat	73
Filling the Water Heater	73
Draining the Water Heater	74
Start Up	74
Switching Off	74
Maintenance	74
Fuse 12v	75
Fuse 230v	75

**TRUMA DIGITAL CONTROL PANEL**

Safety Instructions	76
Display and Control Elements	76
Rotary Push Button	76
Start/Standby Screen	77
Functions	77
Change the Room Temperature	77
Change the Hot Water Level	77
Select Energy Source	78
Select Fan Level	78
Set the Timer Switch	78
Activate the Timer (ON/OFF)	79
Set Time	80
Display Mains Voltage 230v	80
Warnings	80

**EXTERIOR FEATURES**

GRP	81
-----	----

**ROOFLIGHTS**

HEKI Rooflights	81
Safety instructions	82
Care instructions	82
MPK Rooflight	82

**COOKING EQUIPMENT**

Operation	83
Using the Hotplate Gas Burners	83
Using the Electric Hotplate	84
Using the Grill	84
Using the Oven	85
Oven Temperature Control	85
Cooking Guidelines	85
Do's and Don'ts	86
Maintenance and Servicing	86
Service	86

**CARBON MONOXIDE ALARM**

Features	88
Alarm levels	88
Testing	88
Alarm Signals and Warnings	89

**SMOKE ALARM**

Features	90
Simple Maintenance	90

**BATHROOM CARE**

Bathroom Shower Tap	91
Mirrors	91
Ecocamel Shower Head	91

**THETFORD C262 TOILET**

Parts	92
Using The Toilet (Standard)	92
Cleaning and Maintenance	92
Toilet Bowl	92
Waste Holding Tank	93
Winter Operation	93
Preparing the Waste Holding Tank	94
Emptying the Waste Holding Tank	94

**REFRIGERATORS**

Cleaning	95
Maintenance	95
Safety Instructions	96
User's Responsibility	96
Information on Coolant	96
Appliances with Electronics (MES/AES)	96
Operating the Refrigerator with Gas	96



Electrical Operation	98
Mains power 230v	98
Gas Operation	98
Dometic 10 Series Fridge	
Switching ON/OFF	99
Operation	99
Setting Cooling Capacity	99
Thetford N Series Fridge	
Control Panel	100
Switching On	100
Selecting Cooling Level	100
Refrigerator Troubleshooting guide	101

## STAINLESS STEEL SINK

Care	103
------	-----

## SOFT FURNISHINGS

Carpet	104
Upholstery	104
Cleaning and Care	104
Winterisation and Storage	104
Curtains	104

## WINDOW BLINDS

Pleated Window Blinds	105
Cleaning	105
Roller Blinds	105
Re-tensioning	105
Maintenance	105

## GENERAL CARE AND MAINTENANCE OF YOUR CARAVAN

Exterior	106
Cleaning/Usage Information	106

## GENERAL CARE

Acrylic Windows	106
Window Catches and Stays	107
Humidity	107
About Condensation	107
How to Keep Your Caravan Dry	107
Furniture	107

## WINTERISATION & STORAGE

Procedure	108
-----------	-----

## MODIFICATIONS & DIY WORK

Warning	108
---------	-----

## CARAVAN KEYS

Information	108
-------------	-----

## SPARES & AFTERSALES

Accessories	108
-------------	-----

## BED MAKE UP

Front Bed Make Up	109
Rear Dinette Bed Make Up	110
Grande Dinette Make up	111
Retractable Rear Bed	112
Additional Fold Out Rear Bed	112
Free Standing Table	113

## THE SERVICE MANUAL

# BESPOKE ACCESSORIES FOR YOUR CARAVAN

Be prepared for all your adventures with a range of bespoke accessories made to fit your Bailey caravan, ask your local Bailey retailer or visit [www.primaleisure.com](http://www.primaleisure.com)



## 1. Towing covers

Keep your caravan clean and protected from chips and scratches when towing with a tailor-made towing cover.



## 2. Wheel covers

Keep draughts out of your awning whilst protecting your tyres from UV damage with a water proof, breathable and wrinkle-resistant wheel cover.



## 3. Shower mats

Upgrade your shower time with a practical and non-slip bespoke fit shower mat.

## 4. Bedding sets

Get comfortable and unwind in your Bailey caravan with a luxurious bespoke bedding set.



## 5. Hitch covers

Protect your hitch from adverse weather, gravel and bird droppings on-site and in storage with a tailor made hitch cover.

## INTRODUCTION

Congratulations on the purchase of your Bailey caravan. We would like to welcome you to the prestigious rank of Bailey owner. We are confident your caravan will give you many years of enjoyment.

This handbook has been designed to assist you in obtaining the maximum benefits and pleasure from your caravan. The information and hints will be beneficial and help you protect your investment, whether you are a new or experienced caravan owner.

Information leaflets and literature on safe operation of appliances and equipment fitted to your caravan are included in the Bailey information pack. Please read these carefully prior to the use of these appliances.

This manual covers the essential parts of your caravan, however it is not exhaustive. Detailed information can be obtained from individual manufacturers regarding their products.

Failure to observe recommendations or precautions within this or any other related documentation may lead to incorrect operation of equipment. This may cause subsequent risk to occupants.

Regular maintenance is necessary to ensure trouble-free usage of your caravan. Your Bailey retailer is equipped to offer service facilities, repair work and any spare parts that you may require.

Always consult your supplying retailer before any additional equipment is fitted. This is to ensure the location of appropriate structural support.

Retailers are not agents of Bailey and have absolutely no authority to bind Bailey by any express or implied undertaking or representation.

Please be aware that certain sections are only applicable to certain models.

In order to enable Bailey and its retail partners to deal with your queries efficiently, always quote your caravan's vehicle identification number (VIN) which can be found on the offside chassis member. It is also featured on all major windows.

It is policy within Bailey to continuously improve their vehicles. While all illustration and descriptive material within this handbook is correct at the time of going to print, the ever changing market and supply situations may prevent us from maintaining the exact specification details of this handbook. Bailey therefore reserve the right to alter the specification of its products at any time without prior notice.

Bailey offer a variety of leisure vehicles. While each vehicle is designed to feature optimum storage, seating, sleeping and fluid capacities, it is the customer's responsibility to select the correct loads without exceeding the weight capabilities of your chosen towing vehicle. These weights can be found on the weight plate located outside your vehicle next to the exterior door and also on the plate found within the gas locker.

### SAFETY

This handbook contains the information that you will require for your safe enjoyment of your caravan. All the information contained within is important. However, to draw your attention to specific items we have prefixed them with the following symbols to indicate a warning, caution or note respectively.



**WARNINGS** are instructions that if ignored can cause the user(s) physical harm.



**CAUTIONS** are instructions that if ignored can result in damage to the caravan.



**NOTES** are reminders that should be heeded.

## IMPORTANT SAFETY NOTES



To ensure all the occupants of your caravan enjoy a safe and relaxed environment, please observe the following:

- Ensure all the occupants are aware of the vehicle's escape routes.
- Always keep escape routes and exit points clear from obstruction and debris.
- Provide one dry powder fire extinguisher of an approved type or complying with ISO 7465 and BSI 5423 of at least 1kg (2.2lb) capacity by the main door, and a fire blanket next to the cooker. Familiarise yourself with your fire extinguisher.

Your tourer is a compact living environment, and appliances should be treated in the same way as those in the home.

- Always keep young children away from hot surfaces.

Your tourer is supplied with an EN1645 approved caravan step. Always take care when entering or exiting your tourer ensuring that the step is securely located before use. Do not use a damaged or broken step.

- The torque setting of the caravan's wheel bolts should be checked 30 miles after collection from the caravan retailer or after a service or wheel change. Thereafter, wheel bolts should be checked before every journey. The torque settings and tightening sequence are detailed in the caravan and tow vehicle section.
- Never attempt to lift the tow hitch with your hands when hitching the caravan to the tow vehicle or at any other time. Always raise or lower the tow hitch by winding the handle on the jockey wheel.
- Always ensure that the green button located on the leading edge of the coupling head is raised before towing. (Coupling specific).

## STATEMENT OF CONFORMITY



All Bailey caravans have been certified by the National Caravan Council for compliance with UK and European standards and legislation along with industry codes of practice relating to health and safety issues. The approval process covers the testing and inspection of critical areas of the product including fire safety, weights and dimensions, gas, electrics and ventilation. Every Bailey caravan carries the NCC Approved Caravan badge. The NCC conducts unannounced inspections at their members' factories to ensure continued compliance.

NCC approval gives you peace of mind that your caravan is safe and legal.

Your Bailey caravan is also European Whole Vehicle Type approved. This certification assures you that your caravan meets all European regulations and has been constructed to conform to the rigorous standards for both manufacturing and product safety. It enables you to register your vehicle in other European countries.

The certificate of conformity can be found in the document pack provided with your vehicle.

If for any reason a replacement certificate should be needed your Bailey Caravan retailer is responsible for accessing one through the NCC system.

Please refer back to your retailer for additional copies.

### European Representative

AR experts is the legal representation established in the European Union who is duly appointed by Bailey Caravans LTD to represent before the approval authority or the market surveillance authority and to act on the Bailey's behalf in matters covered by Regulation (EU) 2018/858

AR Experts B.V.  
Amerlandseweg 7  
3621 ZC Breukelen  
The Netherlands

## WARRANTY

If you have a problem or enquiry relating to your caravan please follow these steps:

- Check the handbook concerned
- Contact your supplying retailer for assistance.

The following suppliers provide a direct aftersales service.



It is with the retailer that the purchaser's Contract of Sale exists and subsequently Bailey cannot enter into any discussions with the purchaser.

All Bailey products are classified as "portable". All work under warranty requires that the caravan be delivered to and collected from the Bailey retailer.

Every effort has been made within this handbook to accurately reflect and describe Bailey caravan models. Our policy of continued improvements and change in market and supply conditions mean that we reserve the right to alter specification without prior notice. Some materials used in the production of our caravans can result in variations to the figures quoted in respect of measurements and weights.

### TOURING CARAVAN WARRANTY COVER

Total customer satisfaction is top priority at Bailey and the quality ethos extends to the after sales service and market leading manufacturer's warranty package that comes with every new Bailey touring caravan. In this way we not only ensure long-term peace of mind but also enhance the re-sale value of your investment.

### 6 YEAR BODY SHELL INTEGRITY WARRANTY

Bailey Alu-Tech caravans are covered by a six (6) year Bodyshell Integrity Warranty from the initial date of purchase. This cover extends to any structural degradation to the bodyshell that arises as a result of water ingress through any permanently sealed seam or joint (with the exception of exclusions stated in the terms and conditions.)

### WARRANTY EXTENSION

An additional four (4) year extension to the standard Bodyshell Integrity Warranty cover (making 10 years cover in total) is available as a cost option through your supplying Retailer

### 3 YEAR MANUFACTURER'S WARRANTY

For a period of twenty-four (24) months from the initial date of purchase Bailey of Bristol offer a comprehensive warranty on all parts and components as well as full coverage for any manufacturing faults forming part of the original specification of the vehicle, with the following specified exceptions:

The following items are covered for one (1) year from the date of first registration

- Microwave Ovens
- JVC Stereo Radio/CD/MP3 Players & Speakers

The manufacturer's warranty then extends to an additional twelve (12) months on the following items.

- Chassis: all chassis members including corner steadies
- Suspension: axle suspension and braking system (excluding any damage to or faults in brake drums and shoes that are caused through misuse of the braking system or from normal wear and tear)
- Running Gear: road wheels (excluding tyres)
- Towing Mechanism: all mechanical components fitted to vehicle (excluding electrics)
- Cooker: the cooker unit including burners, grill, oven, flame failure device and igniter
- Refrigerator: door seal condenser, gas control valve, gas igniter, flame failure device, 12v and 230v heater elements, gas thermostat, 230v thermostat and 230v temperature control switch
- Water System: water heater (gas or electric), fresh water tank, water pump, water, gauges, taps and shower head
- Electrical System: mains hook up input connector, ELCB, battery charger and distributor unit and interior lighting units (excluding bulbs)
- Cassette Toilet: the cassette toilet is covered (excluding seals, valves and glands)
- Heating System: thermostat, motor, switches, control unit, gas heater, flame failure

- device and igniter (excluding ducting and fittings)
- Windows: the functionality of the opening and closing system (stays, handles and catches) and a warranty against the cracking of the acrylic
- Upholstery: zips, seams and colour fastness

The following items are also not covered for rental vehicles

- Cosmetic damage to interior and exterior fittings and surfaces

### WARRANTY EXTENSION

An additional three (3) year extension to the standard Manufacturer's Warranty cover for mechanical and electrical components of a leisure vehicle both external and internal (making 6 years cover in total) is available as a cost option through your supplying Retailer. Customer Support

Approved Bailey Retailers enjoy industry-leading after sales support service from the manufacturer and they will be able to offer all the help you need to rectify any issues that may occur. They should be your first point of contact on any subject relating to your vehicle. It should be noted that Bailey Approved Retailers sell our products of their own choice and not as agents of Bailey. Accordingly, they have no authority to bind Bailey or make representation or undertaking whatsoever on behalf of Bailey.

### TERMS AND CONDITIONS

The Bailey Warranty Cover set out above is offered subject to the following simple terms and conditions:

#### COVER

1. During the term of the Warranty Cover, subject to these terms and conditions, Bailey will, through an Authorised Service Centre, at its option repair or replace all parts and components of the caravan that are included in the Warranty Cover and which suffer a defect in manufacture or workmanship. An Authorised Service Centre means either Bailey itself, a Bailey Approved Retailer or a Bailey Approved Service Centre. Any part which is replaced becomes the property of Bailey. Any replacement parts are covered for the unexpired term of the Warranty Cover.

#### TERM

1. The initial duration of the Bodyshell Integrity Warranty is six (6) years and the duration of the Manufacturer's Warranty is three (3) years in both cases starting from the original purchase date of the vehicle. It is a condition of the warranty that an annual service is performed on the vehicle in accordance with the service plan. Failure to comply with this term will invalidate the warranty.

2. The unexpired term of the Warranty Cover on your vehicle may only be assigned, transferred or novated to subsequent owners with Bailey's consent (not to be unreasonably withheld) and on payment to Bailey of a transfer fee of £35. Transfer can only be made within the first three months (3) of the date subsequent ownership was taken and full documentary evidence that the vehicle has been serviced annually along with evidence of the date of subsequent purchase (in the form of a VAT sales receipt, invoice or bank/credit card statement) must be provided at the time of assignment in accordance with the terms and conditions detailed above

#### REPAIRS

4. The caravan must undergo a full annual service and inspection, including a moisture survey, carried out, subject to paragraph 5 below, by an Authorised Bailey Service Centre or by a service agent that is a member of the National Caravan Council's Approved Workshop Scheme (AWS).

5. The final annual service in any warranty period must be carried out before the end of that warranty period, but all other annual services may be carried out within six (6) weeks either side of each anniversary of the original purchase date. The original VAT invoices must be retained as proof that these annual inspections have been carried out.

6. Where an annual inspection identifies that repairs to the vehicle are necessary, the caravan must be made available for repair within six (6) weeks of the date of inspection for the purpose of carrying out the repair work. Repairs under warranty must be undertaken by either Bailey itself, a Bailey Approved Retailer or a Bailey Approved Service Centre.

7. No repairs, including the fitting of any replacement unit, may be undertaken or commenced under the terms of the Warranty Cover unless prior written authorisation is obtained from Bailey via a Bailey Approved Retailer or a Bailey Approved Service Centre. No liability will exist with regard to any warranty claims not authorised in this way.

8. Bailey reserve the right to examine the vehicle before any repairs commence or any replacement part is fitted.

**REGISTRATION & USE**

9. The Warranty Registration Form must have been sent to Bailey within six (6) weeks of the original purchase date. It is the responsibility of the Bailey Retailer to forward this information to Bailey. This is part of the terms of trading that the Bailey Retailer has with Bailey.

10. The caravan shall:

- Only be used for its ordinary and intended purpose and shall not be subjected to any
- treatment or conditions which could reasonably be foreseen to cause or result in damage to the vehicle or excessive wear and tear
- Only be towed by a private car or private 4x4 vehicle
- Whilst registered under private ownership must not be put out to hire, reward or any other commercial use, nor used in any race, competitions or rallies whether timed, official or otherwise.

**EXCLUSIONS & LIABILITY**

11. Bailey's liability under this warranty shall be limited to supplying the reasonable costs of labour and materials required for the repair or replacement of faulty parts or components. Bailey shall be entitled to charge for any repair work which is necessitated by virtue of any loss or damage caused by your negligence or default or incurred as a result of any modifications you have made to the vehicle. This warranty does not cover repair costs other than labour and materials.

12. The Warranty Cover does not include:

- Repair or replacement of parts, components, seams or panels which are not part of the original construction of the

caravan, or which have been tampered with or undergone unauthorised modifications, or which have been repaired otherwise than by An Approved Bailey Retailer or a Bailey Approved Service Centre.

- Parts or components other than those specifically listed in the Bodysell Integrity Warranty and Manufacturer's Warranty descriptions set out above
- General maintenance or components failing due to fair wear and tear or normal deterioration repairs necessitated by lack of routine or regular maintenance. Particular attention is drawn to the Owner's Manual and Service Handbook supplied with the caravan and any maintenance instructions or notices published from time to time by Bailey relating to the proper care and maintenance of vehicles
- Structural degradation or other damage caused by water ingress through non-permanently sealed seams or joints (such as, without limitation, around windows, hatches, doors and rooflights), beyond the initial 24 months of the Manufacturer's Warranty.

13. No liability will be accepted for:

- Damage caused by neglect or abuse, corrosion, intrusion of foreign or deleterious substances, lack of servicing, over-heating, freezing, or the continued use of the vehicle after a fault has become evident
- Any loss or damage caused by parts not covered by this Warranty Cover, including soft furnishings or trim
- Any accidental or fire damage or any losses incurred by accident or fire
- Transport costs to and from point of repair.

Bailey will only be liable for costs which are incurred as a direct consequence of the event, defect or fault leading to the claim being made under this warranty. No liability will be accepted for any other loss or damage (such as loss of income or revenue, or loss of business or profits), costs, expenses or other claims for compensation howsoever arising which was not reasonably foreseeable by both parties when the caravan was originally purchased. Bailey will not be liable for any loss or damage suffered by third parties, nor for bodily injury not caused by our negligence.





Nothing in this warranty shall limit in any way our liability: for death or personal injury caused by our negligence; for fraud or fraudulent misrepresentation; or for any matter for which it would be illegal for us to exclude, or attempt to exclude, our liability.

The purchaser has statutory rights in addition to this warranty and this warranty does not affect those statutory rights.

This warranty shall be governed by and construed in accordance with the laws of England and the parties irrevocably submit to the nonexclusive jurisdiction of the courts of England.

**WARRANTY REGISTRATION**

The supplying retailer must explain the warranty terms and conditions to you, and complete the warranty registration process online.

The name and address of the warranty provider is:

Bailey Caravans Limited, South Liberty Lane, Bristol, BS3 2SS

This version: May 2020

Customer's signature:

.....

Date:

.....

Retailer's signature:

.....

Date:

.....

## CENTRAL REGISTRATION AND IDENTIFICATION SCHEME (CRiS)

### **CARAVAN REGISTRATION**

This caravan has been security marked and recorded under the Caravan Registration and Identification Scheme that is recognised by the Caravan Industry and the National Caravan Council.

Shortly after purchasing this caravan you should receive your Touring Caravan Registration Document. It will be sent by post to your home address.

Your Touring Caravan Registration Document will include a 17 character VIN (Vehicle Identification Number), shown in the top right hand corner. This 17 character VIN will also be permanently marked on the caravan chassis.

For security purposes, never leave the Touring Caravan Registration Document in the caravan. It should always be stored in a safe place away from the vehicle.

If you sell the caravan please follow the instructions on the Touring Caravan Registration Document.

If, for any reason, you do not receive a Touring Caravan Registration Document or any of the details recorded are incorrect, please contact:

### **CRiS REGISTRATIONS:**

For help, support and advice Contact CRiS:  
NCC, CRiS Ltd, PO Box 445, Aldershot, GU11 9SF.

**TEL +44 (0) 203 282 1000**

### **VIN Chip Caravan Identification**

The caravan's unique 17 character VIN will be incorporated into VIN Chip tamper evident labels; the master VIN Chip label is situated on the front near side window, others are located in the gas locker and a maximum of 10 placed on the inside of all windows (with the exception of opaque windows).

Three electronic RFID chips containing the individual identity of your caravan are concealed within the caravan and can only be read by using a specially programmed RFID scanner.

## COUNTRY AND COASTAL CODE

### CODE OF CONDUCT - CAMP SITES

Check the site regulations.

### ARRIVALS

Report to reception immediately on arrival.

### VEHICLE MOVEMENT

Keep to roadways unless otherwise directed. Adhere to speed limits. Remember that the stopping distance on grass is considerably greater than on tarmac.

Only a person in possession of a current driving licence may drive onsite.

Park as advised on your pitch. Where possible leave 6 metres (20ft) of free space around your vehicle.

### USE OF SITE

Use the electrical mains hook-up in the correct manner and with caution.

Ensure that all fresh water taps and connections are turned off after use.

Have care and consideration for others when using all facilities. Leave them clean and tidy. Ensure young children are accompanied at all times.

### CAUTIONS

To avoid possible damage to sewage purification works, only approved chemical fluids must be used. Under no circumstances may coal tar, phenol or caustic-based fluids be used. Disposable nappies and similar bulky items must not be put into the chemical closet emptying points but should be wrapped in a polythene bag and placed in the container provided.

### NOISE

All occupants should refrain from making excessive noise.

Flying kites and model aircraft and the use of items like catapults or air guns, as well as ball games, should not be permitted among or close to caravans.

Musical instruments, music players, radios and televisions should not be used to the inconvenience of other people onsite.

Open and close doors quietly.

Power generators must be adequately silenced and used with consideration in accordance to

restricted site times.

### DOGS AND PETS

All dogs and other pets should be kept under control.

Unless permission has been granted, no animal should be let loose on the site and leads should not exceed 3 metres (10 ft).

No animal should be allowed in the shower/toilet block.

Do not let animals foul the site.

### FIRE PRECAUTIONS



Adhere to and make note of all fire precautions, including the whereabouts of the fire points.

It is recommended that a 1kg (2.2lb) dry powder fire extinguisher is carried within the caravan. It should comply with BS 5423 ISO 7465 and be marked BSI or FOC approved. It is important to check at regular intervals that the extinguisher is working as is required by types meeting BS 5423. Ensure the use-by date is frequently checked.

Careful thought is necessary for the positioning of a fire extinguisher, which should be near to the door but not too close to cooking equipment where flames could make it unreachable.

In the kitchen area, a fire blanket is a worthwhile precaution.

Unless permission has been granted, barbecues should not be used. When permission has been given, take care and consider other site users. Ensure that the environment remains pleasant for everyone.

### AWNINGS AND TENTS

Awnings and tents should only be used when permission has been granted.

When on grass and staying for more than a few days, the ground sheet and/or side flaps of awnings should be periodically raised in order to avoid damage to the ground.

### DEPARTURE

Leave the pitch clean and tidy.

Upon leaving, check out with reception, paying the required dues.

Under no circumstances should:

- Litter be disposed of other than in the receptacles provided.
- Water be allowed to escape from the vehicle.
- Chemical toilets be emptied except into the disposal places agreed with the landowner.
- Washing or similar be hung outside of the vehicle.

### HANDBOOK

Before using the caravan, all aspects of the handbooks should be read and adhered to.

### ENVIRONMENT

Care and consideration should be taken to protect the environment.

Observe the Country and Coastal Codes shown below.

### THE COUNTRY CODE

Enjoy the countryside but respect its life and worth.

More people than ever before are exploring the countryside, interested in farming, plant life, bird watching or just observing the general wildlife. Whatever your interest, there is a lot to learn. Please observe the following code.

- Guard against all risk of fires. Hay and heath land can catch alight easily and once ablaze are very hard to put out.
- Remember fire spreads quickly.
- Keep to public paths across farmland.
- Use gates and stiles to cross fences, hedges and walls.
- Leave livestock, crops and machinery alone. View from a distance.
- Take your litter home; it is unsightly and harmful to wildlife.
- Help to keep all water clean.
- Take special care on country roads.
- Make no unnecessary noise. Most animals are timid, noises can disturb them unnecessarily.

If you want to get the best out of the countryside, travel around as quietly as possible.

### THE COASTAL CODE

As our coastlines are increasingly used for recreation and education, the following suggestions are made to enable us to enjoy our inheritance and preserve it for posterity.

- Do not trample about, or move rocks unnecessarily.
- Do not frighten seals or sea birds.
- Do not spear fish.
- Live molluscs and crustaceans should not be collected as souvenirs, dead shells can usually be found;
- Shellfish can take years to grow and fines can be imposed for not observing national regulations.
- Do not pull up seaweed unnecessarily.
- Make your visit instructive, not destructive.
- Look at material, don't remove it.
- Observe bye-laws and be considerate to others.
- National Trust property or Country Parks have regulations to protect the wildlife. Follow these.

### ROOF LOADING



Do not climb on the roof of your caravan.

### SAFETY AND SECURITY



Your attention is drawn to the notice fixed in your Caravan advising on fire protection, ventilation and what to do in case of fire.

### CHILDREN

Never leave children alone in the caravan. Ensure all potentially dangerous items are kept out of reach.



When upper bunks are used by children, especially those under the age of six (6), care should be taken to ensure against the risk of them falling out. These bunks are not suitable for use by infants without supervision.

**UPPER BUNKS**

Please ensure upper bunks are only used for sleeping. When upper bunks are used fall out protection must be always be in place.

**FIRE EXTINGUISHERS**

It is recommended that a 1kg (2.2lb) minimum capacity dry powder fire extinguisher be located near to the main habitation entrance door.

A pan fire should not have a fire extinguisher aimed at it. A fire blanket should be used. This should be within easy reach of the hob but away from the source of flames.

**IN CASE OF FIRE**

- Get everyone out of the caravan as quickly as possible using whichever exit is quickest, including windows.
- Raise the alarm - call the fire brigade.
- Turn off the gas bottle valve if it is safe to do so.



Your caravan is fitted with a smoke alarm. The operation of the alarm should be tested after the vehicle has been in storage, before each trip and at least once per week during use.

**VENTILATION AND CONDENSATION**

The ventilation points on your caravan are fixed points specified by European standards. Under no circumstances must these be blocked or obstructed. It is advised that fixed ventilation points and any protective screens are checked and cleaned on a regular basis.

Fresh air circulation should be allowed below the caravan when appliances are in use and when flues terminate below the floor to allow free evacuation of the products of combustion. At least three sides of the under-floor space should be kept clear and unobstructed, including by snow. Do not make any additional openings in the floor.

Additional night-time ventilation is obtained by releasing the window catches and placing them in the second groove on the frame catch.



Under no circumstances should the caravan ventilation be covered, blocked or tampered with in any way.

**PETROL AND DIESEL FUMES**

The fitting of a tail pipe deflector to your exhaust will reduce the possibility of fumes entering your caravan through the front fixed ventilation points. However fitting an extension to an exhaust tail pipe will render the exhaust illegal if it projects beyond the vehicle body or bumper.

**ORIGINAL EQUIPMENT APPLIANCES**

See sections devoted to individual appliances.



Replacement parts for any appliance must conform to the appliance manufacturer's specification, and must be fitted by an authorised agent.

**PORTABLE APPLIANCES**

Never use portable cooking or heating equipment, other than electrical heaters that are not of the direct radiant type.

**MODIFICATIONS**

Never allow modification of electrical or LPG (liquefied petroleum gas) systems and appliances except by qualified persons.



In the interest of safety, replacement parts for an appliance shall conform to the appliance manufacturer's specifications and should be fitted by said manufacturer or authorized agent.

## CARAVAN AND TOW VEHICLE

Choosing the right car and caravan combination for safe and stable towing is an important process. It may seem complicated to the newcomer, but a few minutes spent learning the basic principles, common terms and definitions will be worthwhile in the long term and ensure your enjoyment of the caravan.

### CARAVAN AND TOWING VEHICLE TERMS

#### MAXIMUM TECHNICALLY PERMISSIBLE LADEN MASS (MTPLM)

As stated by the vehicle manufacturer. This mass takes into account specific operating conditions including factors such as the strength of materials, loading capacity of the tyres etc. MTPLM is the maximum permissible weight of caravan on the road.



Under no circumstances should the MTPLM of the caravan be exceeded.

#### MASS IN RUNNING ORDER (MRO)

Mass of the caravan equipped to the manufacturer's standard specification and essential habitation equipment.

#### USER PAYLOAD

The difference between the maximum technically permissible laden mass and the mass in running order.

The user payload includes:

Personal Effects: Those items which a user chooses to carry in a caravan and certain items of habitation equipment which are not included in the MRO or Optional Equipment.



Personal effects will include any items not supplied as standard by the manufacturer. This includes 25kg for the leisure battery.

#### OPTIONAL EQUIPMENT (OE)

Items made available by the manufacturer over and above the standard specification of the caravan. These are factory fitted options.



Please make sure your personal effects stay within the allocated payload. In no circumstances should the caravans actual weight exceed the stated MTPLM.

Please note: weigh bridges may give varying (possibly inaccurate) results.

Nose Weight: The downward force (or weight) of the caravans coupling head on a car's towball. This is sometimes defined as the "static load at the coupling head". The maximum nose weight for a caravan will be limited by either the towing vehicle tow hitch limits or the maximum load to which the caravan hitch is specified.



The towing vehicle and towing hitch handbooks/manufacturer's guide must be consulted for their specification prior to towing.



The maximum static nose weight for all Bailey caravans is 100- 120kg. This should never be exceeded regardless of whether the towing vehicle's upper limit is greater.

It is recommended that the nose weight should be varied to find the optimum weight for towing dependent upon the actual laden weight of the caravan.

#### MEASUREMENT OF THE NOSE WEIGHT

Nose weight may be measured using a proprietary brand of nose weight indicator. Such equipment is obtainable from your Bailey retailer.

#### KERB WEIGHT

The weight of the towing vehicle as defined by the vehicle manufacturer.

This is normally:

- With a full tank of fuel
- With an adequate supply of other liquids incidental to the vehicle's propulsion
- Without any drivers or passengers
- Without any load except loose tools and equipment with which the vehicle is normally provided
- Without any towing bracket.

## THE CARAVAN TO TOWING VEHICLE WEIGHT RATIO

The caravan should never exceed the weight of the towing vehicle.

The optimal combination is a caravan that weighs less than 85% of the towing vehicle's kerb weight.

This is licence entitlement dependant as post 1997 further restrictions apply.

The following equation can be used to calculate the above.

$$\frac{\text{Actual laden mass of caravan}}{\text{Kerb weight of towing vehicle}} \times 100 = \%$$

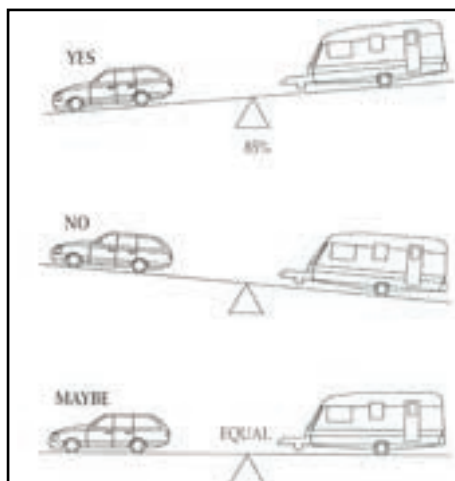

As a general guide:

- Conventional engines with a capacity of up to approximately 1600cc petrol or 1800cc diesel should be adequate for towing a caravan weighing around 85% of the kerb weight of the towing vehicle.
- Engines above 1600cc petrol or 1800cc diesel should manage a caravan weighing up to 100% of the kerb weight of the towing vehicle and still give adequate performance.

The towing vehicle's manufacturer towing limit is, in some cases, less than the kerb weight. Vehicles with automatic transmission may need an oil cooler fitted or the SAE (Society of Automotive Engineers) rating of the gearbox fluid increasing when towing. The advice of the vehicle manufacturer should be sought. The law requires that caravans, their towing vehicles and the loads they carry must be in such a condition that no danger or nuisance is caused.

## TOWING VEHICLE'S REAR SUSPENSION

It is important that the towing vehicle's rear suspension is not deflected excessively by the nose weight. If it is excessive the steering and stability will be affected and at night the headlight beam is likely to dazzle other drivers.

It is important to ensure that the caravan is towed either level or slightly nose down. If it is not, then the car's towbar may be at the wrong height.



Always consult your tow vehicle manufacturer for advice on towing and the loads that the vehicle is capable of towing.

## RECOMMENDED TOWBALL HEIGHT

The recommended towball height for Bailey caravans is 385 +/- 35mm (350mm to 420mm).

## SECONDARY BRAKING CABLE (BREAKAWAY DEVICE)

Purpose - To apply a trailer's brakes if it becomes separated from its towing vehicle. Having done this, the cable assembly is designed to part, allowing the trailer to come to a halt away from the towing vehicle. Construction; A thin steel cable, coated in red plastic and fitted with a means of attachment for connection to the towing vehicle.

**Beginners Guide Video,  
Scan to view:  
Loading and your Caravan**





Operation - In the event of the main coupling of the trailer separating from the towing vehicle, the cable should be able to pull tight, without any hindrance, engaging the trailer's brakes.



The breakaway cable should never become taut during normal use.

Regularly check the cable and clip for damage. If in doubt, contact your trailer or towbar supplier or your service agent.

Make sure the cable runs as straight as possible and goes through a cable guide underneath the trailer coupling.

Determine whether or not the towbar has a designated attachment point (i.e. a part specifically designated by its manufacturer for a breakaway cable).

Where a designated attachment point is provided on the towbar:

- Pass the cable through the attachment point and clip it back on itself.

Where no designated attachment point has been provided on the towbar:

- Fixed ball: Loop the cable around the neck of the towball. Use only a single loop.
- Detachable ball: You must seek guidance on procedure from the towbar manufacturer or supplier.

#### OTHER MEANS OF ATTACHMENT



It is a legal requirement that the secondary breakaway cable is used when towing.

In some instances it may be possible to attach the cable assembly:

- To a permanent part of the towbar structure, as long as this meets the approval of the towbar manufacturer/supplier,
- To an accessory sold for the specific purpose of breakaway cable attachment.

When the breakaway cable is attached, check to ensure:

- That the cable cannot snag in use on the caravan coupling head, jockey wheel, or any accessory, e.g. a stabiliser, bump shield, cycle carrier, etc.
- That there is sufficient slack in the cable to allow the towing vehicle and caravan to articulate fully without the cable ever becoming taut and apply the brake. For peace of mind you might wish to check the state of the cable by positioning the caravan and towing vehicle at extreme angles before setting off.
- That it is not so slack that it can drag on the ground. If left loose, the cable may scrape along the ground and be weakened so that it subsequently fails to do its job. The cable may also be caught on an obstacle when in motion, thus engaging the caravan's brakes prematurely.

Having followed this advice, should you feel that a satisfactory coupling arrangement cannot be achieved, consult your trailer/towbar supplier or service agent.

#### LOADING AND DISTRIBUTION OF WEIGHT IN THE CARAVAN AND CAR.

Equipment and personal effects should be loaded in the caravan so that any heavy items are low down near to the floor and mainly over the axles.

The remainder should be distributed to give a suitable nose weight at the towing coupling.

It should be noted that with certain layouts or models it may be necessary to load heavy items, such as awnings, in the middle of the floor to achieve an acceptable and safe nose weight. It may not be possible to achieve the desired nose weight with all items stored out of sight in lockers and bed boxes (bunks).

Please take care that you have allowed for the weight of all items you intend to load into the caravan.

#### NOSE WEIGHT

It is recommended that the nose weight should be varied to find the optimum weight for towing, dependent upon the actual laden weight of the caravan. Experience has shown

that the nose weight should be approximately 7% of the actual laden weight (i.e. between 50 and 100kg). However, this may be limited by the towing vehicle or caravan manufacturer's limit nose weight. Check with the car handbook, or consult your retailer. The upper limit for the caravan coupling head is 100kg - 120kg

### HITCHING UP

Before hitching up the vehicle always check the following:

1. All wheel bolts are tightened to the correct torque. When fitted with alloy wheels, bolts should be tightened to a torque of 130Nm (Newton metres). For the steel spare wheel supplied with the caravan the wheel bolts should be tightened to 120Nm.

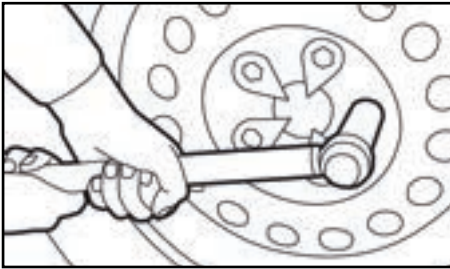

2. Inspect all wheels and tyres for signs of deterioration or damage.
3. Tyre pressures are correct checking spare wheel if one fitted.

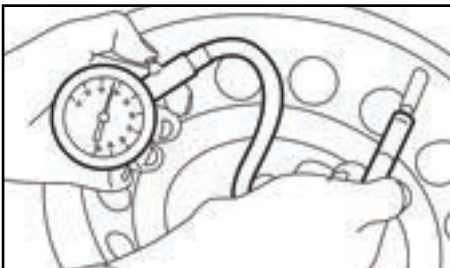

4. Ensure all loose articles are stowed securely. Do not store heavy items in roof lockers. Televisions and other heavy items must always be secured at floor level when towing.
5. All lockers and cupboard doors are closed and secured.

6. All bunks are secure.
7. All rooflights, extractor fans and sunroofs are closed and secured.
8. Tables are secured in their transit position.
9. Fridge is on 12v operation and the door lock is set (if required).
10. All windows are fully closed and latched. Never tow with windows on night setting.
11. Gas cylinders are correctly positioned, secured and turned off, and the gas box is shut and locked.

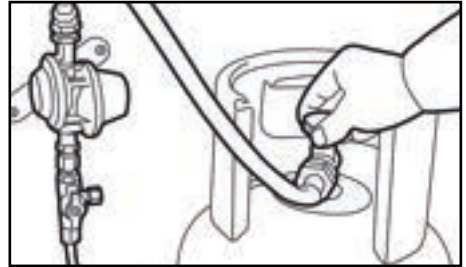

12. Ensure no loose items are stored in the gas box and it is not over filled with equipment, as this may cause impact damage to the inside of the panel.
13. Battery is connected and the battery is secure.
14. All external doors, flaps and ventilation ducts are closed and secure, with their relevant covers in place.
15. It is recommended that a minimum of 2 people work together when hitching up the caravan to the tow vehicle.

### HITCHING THE CARAVAN TO THE TOW VEHICLE

1. Ensure that the caravan is in a suitable position, and secure with the handbrake fully on.
2. Fully raise all four corner steadies.
3. Shut and lock the caravan exterior.
4. Gauge the height of the car's towball then raise or lower the height of the caravan's towing hitch to ensure that it is high enough to pass over it cleanly and not hit the towball. Rotating the caravan's jockey wheel handle can do this: Clockwise to lower, anti-clockwise to raise.
5. The assistant should position themselves by the front near side of the caravan so that they can extend an arm horizontally to indicate the position of the caravan's

towing hitch.

6. Remove the car's towball cover and keep it in a secure place in the car.
7. Slowly reverse the towing vehicle towards the caravan. When reversing the towing vehicle towards the caravan always ensure that any pedestrians and your assistant are visible at all times.
8. When reversing aim the towball of the car directly at the caravan towing hitch.
9. When the car's towball is as near to the caravan's towing hitch as possible fully apply the car's handbrake, turn off the engine and leave the car in first gear (Park or 'P' position for automatics).
10. Carefully release the caravan's handbrake.
11. Manoeuvre the caravan's tow hitch directly over the towing vehicle's tow ball. Always manoeuvre the vehicle by pushing/pulling on the grab handles. When the caravan is in the correct position fully apply the handbrake.
12. Raise the handle on the caravan tow hitch until it clicks and remains at an angle.
13. Rotate the jockey wheel handle clockwise to lower the hitch onto the towball. When the tow hitch clicks and the handle drops to the horizontal position it is engaged. The hitch head is fitted with a visual indicator on the front radius to show whether or not it is properly connected to the tow ball. A green band will show immediately below the red indicator button on the hitch head when a proper connection has been made.
14. Connect secondary braking cable as per the instructions in the previous section.
15. Test that the hitch is now fully engaged by slightly raising the caravan hitch from the car towball by winding the jockey wheel handle anti-clockwise. The hitch should not release from the car towball. Only raise the rear of the car enough to check the hitch is fully engaged. See Alko manual for further information on hitching up, unhitching and fault identification.
16. Turn the jockey wheel winding handle to lower the caravan. When the wheel is fully retracted, release the clamp and raise the jockey wheel to travel position.
17. Once the jockey wheel is in travel position and the wheel is located in the recess, tighten the clamp again.
18. All caravans are fitted with a single 13 pin lead. Where the connector for the car does not match that of the caravan an adaptor

or replacement cable will be required. Please ask your supplying retailer for details.

19. Connect the lead to the receiving socket on the towing vehicle ensuring there is enough loose cable for cornering, but not too much so that it can drag on the ground.



20. Check all towing vehicle and caravan road lights are working, and the operation of the brake lights. If ATC fitted check the LED on A frame cover is green.
21. Pick up any levelling pads or levelling boards.
22. Fully release the caravan handbrake.
23. Carry out a second check that the hitch is secure and the secondary braking cable is connected.
24. Adjust the car's driving mirrors from the driving seat to ensure good rearward visibility.



Personal effects will include any items not supplied as standard by the manufacturer. This includes 25kg for the leisure battery.

**Beginners Guide Video,  
Scan to view:  
Hitching up**



## TOWING

### TOWING VEHICLES

Your new caravan is designed to be towed by a normal motor car.

If you intend to tow it with a Pick-up type vehicle, car derived van or a 4x4 vehicle additional care should be exercised due to the potential of harder rear suspension imposing excessive loads/force onto the caravan.

You may also have to adjust your driving style over rough terrain. Particular attention should be given to the height of the tow ball in relation to the caravan coupling.

Your new caravan should not be towed by a commercial vehicle with a gross vehicle weight in excess of over 3500kgs.

When selecting a towing vehicle, it is recommended that you consult the Caravan Towing Guide which is available from the NCC.

### SPEED LIMITS

Where a lower limit is not in force, caravans may be towed at up to a maximum of 50 mph on single carriageways or 60 mph on dual carriageways and motorways. For further information on towing regulations can be found in the Highway Code.

### PULLING AWAY

- Allow more engine speed to produce the power to move the additional weight of the caravan.
- Always let the clutch out smoothly, to avoid wear and tear on the clutch plate and transmission.
- Change gears smoothly. Ensure optimum revs are always used when changing gears.
- Try not to drop the clutch.

### CARAVAN HANDLING

- Make allowances for the caravan being slightly wider than the car.
- Allow additional distance from the kerb with caravan wheels so that they are not "kerbed".
- When passing other vehicles allow more than normal clearance for driving solo.
- Overtaking and stopping distances are increased when you are towing.
- Always indicate in plenty of time before carrying out any manoeuvre.
- Allow longer to accelerate up to speed prior to overtaking.

- Allow for the vehicle being twice its normal length.
- Do not suddenly swing out.
- Carry out all manoeuvres as smoothly as possible.

### REVERSING

Skilled reversing can only be achieved with practice and should be first attempted in an open area. Consider a suitable training course.

### MOTORWAY DRIVING

Caravans may not be towed in the outside lane of three or four lane Motorways (Reg 12(2) of the motorway Traffic [England and Wales] Regulations 1982).

Reduce speed in high winds, cross winds, driving downhill or in poor visibility. High-sided vehicles such as lorries or coaches can cause air buffeting, so extra care must be taken when passing or being passed. Give as much space as is possible between your caravan and the high-sided vehicle.

### MIRRORS

The law requires the driver of the towing vehicle to have an adequate view to the rear. If there is no rear-view through the caravan windows it may be necessary to have additional exterior towing mirrors fitted to provide a view along both sides of the caravan. In some countries these additional mirrors are a legal requirement.

Any rear view mirror must not project more than 200mm outside:

- The width of the caravan when being towed.
- The width of the towing vehicle when driven solo.

Any additional rear-view mirror fitted shall be of an approved European type and cover the field of view as stipulated by the regulators.



Passengers are forbidden to ride in a caravan at any time.

### SNAKING

This is a term used to denote an unstable car and caravan combination where the caravan "weaves" from side to side often causing a similar swaying movement in the car itself. Possible causes are:

- Insufficient tyre pressure on either the caravan or the tow vehicle.
- Tow vehicle is too light.

- Incorrect loading or weight distribution.
- Excessive speed especially downhill.
- Side winds.
- Overtaking.
- Being overtaken by a high-sided vehicle.
- Erratic driving.
- Mixing radial and cross ply tyres.
- Nose of the caravan is towing too high.
- Insufficient nose weight.

### STABILISERS

A stabiliser should never be used to try to improve a caravan/towing vehicle combination that has poor stability as instability may appear at high speed.

However, a good stabiliser can make an acceptable caravan and towing vehicle combination more comfortable and easier to handle.



Holes should not be drilled in either the coupling head or A frame members without prior consultation with the chassis manufacturer.

If you encounter snaking, try to keep the steering wheel in a central position, slow down gently and avoid braking if possible.

### ROAD LIGHTING

All caravans are fitted with a single 13 pin lead. When the connector for the car does not match that of the caravan an adaptor or replacement cable will be required.

Please ask your supplying retailer for more information.

It is important that all the road lights on your Bailey caravan are checked before you set out on a journey.

All lights must be working in the correct manner for the vehicle to be road legal.

Clean the outside of the lights with a non-abrasive or non-aggressive cleaning solution on a regular basis.

Always replace a lamp which is showing any sign of damage.

### 13 PIN PLUG

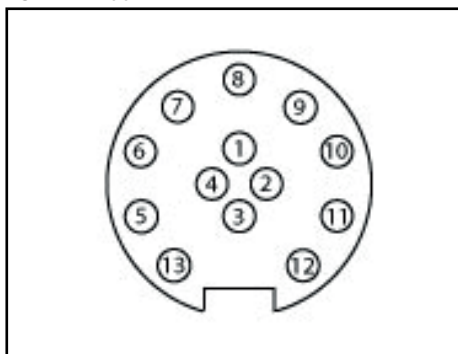

KEY:

1. Left-hand direction, indicator light
2. Fog light
3. Common return for Core # 1, 2 and 4 to 8.
4. Right-hand direction indicator light
5. Right-hand rear position and marker lights and rear registration, plate illumination device.
6. Stop lights
7. Left-hand rear position and marker lights and rear registration, plate illumination device
8. Reversing light
9. Continuous power supply
10. Power supply controlled by ignition switch
11. Return for core # 10
12. Coding for coupled trailer
13. Return for core # 9

Within your accessories pack you will find a green 13 pin plug protection screw on cap. This should be used every time you connect your caravan to your vehicle. This will help to protect the 13 connections from corrosion. If you find corrosion on you connections please spray with water displacement spray. When disconnected from car place in storage socket on A frame to prevent corrosion. The green cap is a pin alignment tool used to align the plug pins in the housing.

### TOWING BRACKETS

All tow cars registered since 1 August 1998 must be fitted with a European type-approved towing bracket, by law. It is recommended that other cars not affected by this law use only towing brackets designed and tested to British Standard BS (AU) 114b, or ISO 3853.

## UNHITCHING

- Do not pitch in a position in which your outfit will obstruct other people.
- Try to choose an area that is dry, reasonably level and preferably on hard standing ground.
- If you have no alternative but to pitch on a slope, ensure that you are facing down the slope for when you leave.
- It is good practice to chock the wheels of the caravan when parked on a slope even when the caravan brakes are applied.

### PROCEDURE

1. Fully apply the caravan handbrake.
2. Unclasp and lower the jockey wheel to the ground.
3. Re-clamp it in this position.
4. Pull the stabiliser lever up as far as it will go, open the coupling handle and lift from the towball. With larger nose loads, coupling and uncoupling can be made easier by using the jockey wheel to assist lifting.
5. Re-clamp jockey wheel if necessary.
6. Disconnect the secondary braking cable.
7. Disconnect the 13 pin plug and return it to its holder.
8. Replace towball cover.
9. Park your vehicle alongside the caravan on the offside.



Serious damage will occur unless the button is depressed first and the handle lifted forward before the caravan is lifted manually. This prevents the nose weight being transmitted through the button.

## LEVELLING THE CARAVAN

Levelling must be carried out in both directions in order for the refrigerator and other equipment to function correctly. A spirit level can be used as shown in the picture.

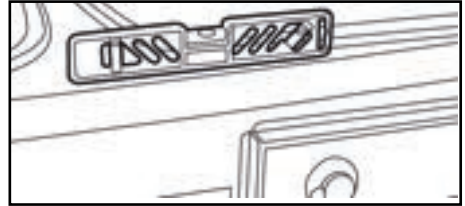

The positioning of the jockey wheel can be used to help level the caravan.

The jockey wheel can be used to level the caravan from front to back. On a badly sloping pitch the jockey wheel may not lower the front of the caravan sufficiently after unhitching. If this is the case lower the front stabiliser legs, unclamp the jockey wheel and raise them reclamp. The stabiliser legs can then be raised and the jockey wheel used to lower the front of the caravan.

Note you may have to repeat this process in reverse if the jockey wheel can not raise front of caravan sufficiently to hitch up to tow car.

Lower the corner steadies until they are in firm contact with the ground.



Under no circumstances should the corner steadies be used as a jack as they are only a means of stabilising the caravan.

Levelling pads or boards should be used under the steadies where the ground is soft or uneven. In extreme cases where it is necessary to raise a wheel off the ground for levelling purposes, further adequate support should be applied under the wheel so that the corner steadies do not take any undue strain.

**Beginners Guide Video,  
Scan to view:**

Levelling your caravan



## WHEELS AND TYRES

All Bailey vehicles use branded tyres. These are subject to change at any point without prior notice.

### TYRES

The tyres on Bailey caravans are suitable for towing at sustained speeds of up to 81 mph (130 kph) to allow for use in countries which permit these speeds.

Radial and cross ply tyres should never be mixed. It is dangerous and can cause snaking. Fit only tyres that are of identical specification on each side, unless towing for a limited time on the spare wheel.

### TYRE WEAR AND DAMAGE

The legal requirements for tread depth on motor vehicles also applies to caravans.

In order to equalise wear it is suggested that wheels be balanced and changed around from time to time. When caravans are not in use for extended periods, wheels and tyres should be removed and stored in dry conditions and away from the outside elements. Alternatively caravans should be jacked up to relieve the load from the tyres.

It is dangerous to neglect tyre damage. Tyres should be checked for damage or cuts exposing the casing. If a tyre has suffered an impact (for example against a kerb) it is advisable to have it examined by a tyre specialist as soon as possible.

The caravan industry recommends that for safety reasons tyres more than 7 years old from the date of manufacture must be replaced, but preferably replaced at 4 years old. The tyres may have deteriorated by this time, regardless of tread depth. The cleaning of tyres should only be carried out using soap and water. Petrol, diesel, paraffin and other solvents are not suitable.

If the caravan is not used for long periods of time (periods of longer than 1 month), it is recommended that the wheels/tyres are removed and stored upright in a rack and rotated at least once a month to avoid the tyres becoming distorted. They can be covered

with a natural material (e.g. hessian) for protection but NOT plastic materials. This will reduce the deterioration of the tyres and reduce the cracking and flat spots caused by continuous loading and external conditions. It is recommended to protect tyres from direct sunlight.

If it is not practical to remove the wheels it is recommended to routinely rotate the wheels to reduce the potential of cracking, flat spots etc.



Check with your insurance company that you are still covered when the wheels are removed.

### TYRE PRESSURES

Caravan tyres should be at the pressure recommended. The towing vehicle's tyres should be set to the pressure recommended by the vehicle manufacturer for laden conditions. This will ensure the tyres and vehicle operate in a safe condition and maintain stability of the vehicle when towing.

Always check your caravan and tow vehicle tyre pressures when cold and prior to any journey. Also check tyre conditions for damage or cuts exposing the casing before and after any journey (this includes the spare.) If in doubt it is advisable to have it examined by a tyre specialist as soon as possible. Incorrect tyre pressures can seriously affect towed vehicle performance and the longevity of the tyre.

Consult your tow vehicle manufacturer for the correct tyre pressures for towing.

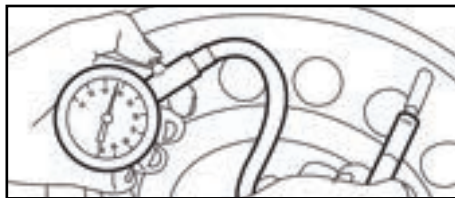



**WHEELS**

Caravan wheel bolts must only be tightened to the appropriate setting by tightening each opposite fixing in succession to the correct torque. Always use a calibrated torque wrench. Do not use a corner steady brace, power or electric wrench. It is as dangerous to over-tighten bolts as it is to not tighten them sufficiently.



The torque settings should be checked after the first 50km/30 miles. For alloy wheels the wheel bolts should be tightened to a torque of 130Nm (Newton metres) (96 lb-ft). For steel wheels the wheel bolts should be tightened to a torque of 120Nm (88 lb-ft)

The condition of wheels should be checked regularly, particularly for distortion of flanges and the wheel dish. Damaged or distorted wheels, or having the wheel bolt seating cracked or deformed, must not be repaired.

If a wheel or tyre has to be changed it should be of the same type of construction and size as originally fitted.



Only use a spare wheel and tyre recommended by Bailey Caravans, which should be of the same specification as those fitted to the caravan.

Always ensure mating surfaces and bolt seating areas are clean and dry. Wheel bolts should never be lubricated.

**SPARE WHEELS**

The spare wheel fitted to your caravan is an unbranded tyre.

1. Always ensure that the tow vehicle and caravan are in a safe position before attempting to change the caravan's wheel. We recommend leaving the caravan hitched to the tow vehicle when changing a wheel. The tow vehicle should be left in gear (or "P"/Park for an automatic) with the handbrake on both the car and the caravan fully applied.
2. Lower the corner steadies as a safety measure to stabilise the caravan. Chock the unpunctured wheel on the opposite side of the caravan to prevent any movement.
3. Slacken off the wheel bolts by no more than one quarter of a turn on the wheel that requires changing. Do not fully undo them.
4. We recommend you only use an AL-KO jack on the AL-KO chassis. Please refer to your AL-KO handbook for jacking instructions.
5. The wheel that is to be removed should be lifted just off the ground.
6. Remove the wheel bolts and remove the wheel.
7. Fit the spare wheel, and reverse the above procedure. Ensure the wheel bolts are all fitted, and tightened in the correct sequence. Ensure correct torque setting (see Service Manual for torque settings).
8. Remember to check the torque of wheel bolts after 50kms/30 miles.



Under no circumstances should the corner steadies be used as a jack. They are only a means of stabilising the caravan.

## SPARE WHEEL CARRIER

The AL-KO spare wheel carrier is fitted to certain models of Bailey caravans.

### To LOWER THE SPARE WHEEL:

It is advisable to jack the caravan first to increase the space under the caravan to help with removal and ease of access.

To remove the carrier, first remove the securing hook and loosen the star handle. Gently pull the carrier by the two handles away from the chassis until it is clear of the chassis. Pull the carrier out until the spare wheel is visible and loosen the nuts and lift off the spare wheel.

Reverse the process to return the carrier under the chassis, tighten the star handle and refit the securing hook.

## Maintenance

In order to ensure that the spare wheel carrier is working properly, the telescopic tubes must be cleaned at regular intervals to ensure that any dirt and debris that can accumulate during usage and journeys does not cause the tubes to stick. The tubes should not be greased.

## TPMS TYRE PRESSURE MONITORING SYSTEM (SUPPLIED WITH CERTAIN MODELS OF BAILEY CARAVAN)

This system is designed to monitor the pressure and temperature of wheels and tyres that have been fitted with TyrePal TPMS internal sensors. Additional sensors can be purchased to monitor spare wheels, or the tyres on the towing car.

The system continuously monitors tyre pressure and temperature while the caravan is in motion and gives distinct alerts in the event of:

- Rapid pressure loss
- Low tyre pressure
- High tyre pressure
- High tyre temperature

The system can monitor up to 22 tyres on a car and trailer.



The system does not replace the need to carry out regular checks on the condition, age and wear of tyres.

For full details and instruction on how to use/set up your TPMS please see the manual supplied with the unit.

## THE AL-KO AKS STABILISER AND COUPLING

The trailer coupling may only be connected to towing vehicles where clearances for the stabiliser can be observed, in accordance with EC Directive 94/20 (DIN 74058). If these clearances are infringed by special attachments, then the use must be checked separately.

The area above the towball of the vehicle must be free from vehicle components or attachments (A) (e.g. spare wheels, platforms etc.)

The clearance for the stabiliser lever must be at least 330mm (B) + the stroke movement (D) (85mm-100mm), which equates to 440mm when used in conjunction with an AL-KO overrun.

Max. 50mm (C) clearance between the centre of the towball and top of the overrun assembly or fairing, to ensure both coupling handle and stabiliser lever do not foul on operation.

Swan neck towbars (fixed or detachable) are suitable for use with the AKS 3004 providing they comply to EC Directive 94/20 and have the required minimum 60mm clearance, measured from the centre of the towball.

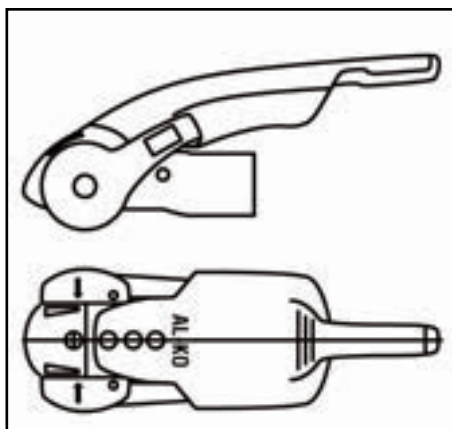
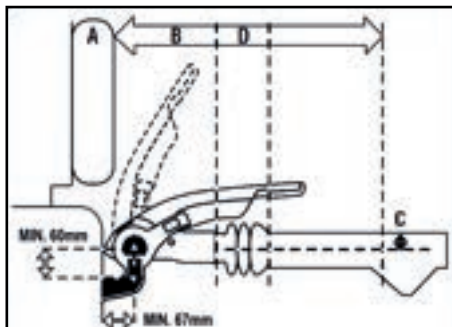

FIG. 1.

### OPERATING INSTRUCTIONS

Coupling handle and stabilising lever.

The stabiliser lever (Fig.3/ Item 2) must be in the uppermost position (open).

### COUPLING

Pull the coupling handle (Fig. 2/Item 1) up in the direction of the arrow. The coupling mechanism has an open position, i.e. as long as the AKS 3004 is not placed on the ball, the handle will remain open. Put the opened coupling onto the clean towball. The handle must now make an audible click and return to the flat position.

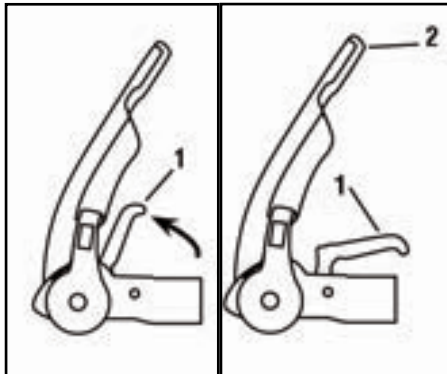

FIG. 2.



The coupling is correctly engaged when the green edge of the safety indicator button is visible (Fig. 4/Item 3.)

Always ensure that the jockey wheel is fully raised and secure before commencing any journey.

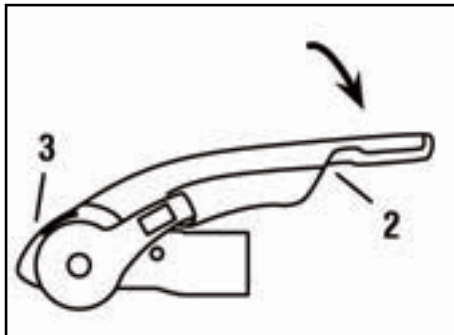

FIG. 4.

**STABILISER UNIT**

To operate the stabiliser (once coupled to the towball), simply press the stabiliser lever down as far as it will go (Fig. 4/Item 2).

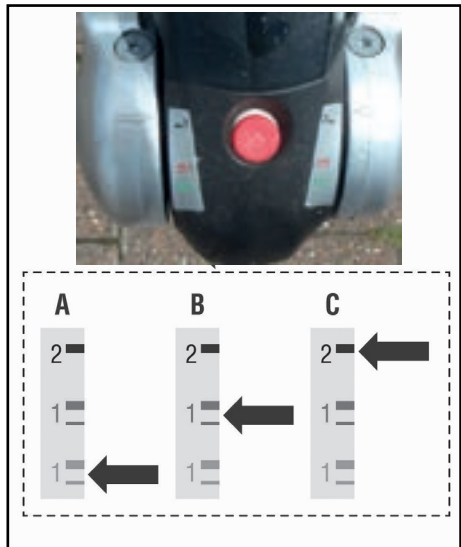

FIG. 5.

**UNCOUPLING**

Pull the stabiliser lever handle up as far as it will go, lift the coupling handle and lift the AKS 3004 from the towball. With larger nose loads, coupling and uncoupling can be made easier by using the jockey wheel to assist lifting. The friction pads are pressed against the towball and hence generate a stabilising/damping force. These pads are therefore subject to wear over time; however they will have a long service life (circa. 30,000 miles), provided they are well maintained and kept free of grease/dirt.

Having lowered the jockey wheel to the ground, operate the handle as previously described. Lift the coupling clear of the towing ball either manually or by operating the telescopic jockey wheel.

Checking the efficiency of the left/right friction pads:

1. Check that the stabiliser is correctly coupled by ensuring the coupling handle is fully down and the red indicator button is in the raised position.
2. Push the stabiliser lever (fig.5/item 1) down until resistance is felt (i.e. the friction pads are in contact with the ball but not yet under pressure).

3. Check the position of the arrowhead on the arm of the stabiliser. If it lines up with the two green lines then the friction pads are still as new (Fig.5/A)



If the arrowhead lines up with the two red lines then the friction pads are worn and should be replaced immediately.

When the stabiliser lever is correctly applied, the arrowhead should link up with the black line marked 2 (Fig 5/C).

The friction pads do not require any form of lubrication and should be cleaned with a fine emery paper prior to every journey. It is not necessary to adjust the friction pads.

### MANOEUVRING OPERATION

For easier manoeuvring (on camp sites etc), pull the stabiliser lever to the "up" position. Please do not use the stabiliser lever as a manoeuvring handle. Please use the handles on the caravan or fit the AL-KO manoeuvring handle to your jockey wheel (available separately).

1. During opening or closing, the AKS must only be operated by one person.
2. Press the stabiliser lever down by hand only, DO NOT use your foot or an extension bar: this will damage the components (Fig. 6).
3. When opening or closing the stabiliser lever, please ensure your hand does not touch the coupling handle to avoid injury (Fig. 6.)

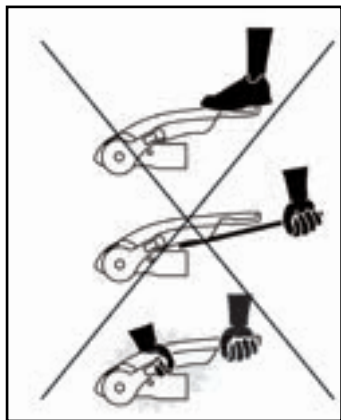

FIG. 6.

### NOISES WHILE DRIVING

As a rule, the friction pads of the AKS 3004 do not make a noise during driving. Any clicking, creaking or squeaking noises that do arise may be due to the following:

1. Foreign bodies or dirt between the friction pad and towball.
2. Dry operation of the draw-shaft inside the overrun device.
3. A detachable towball which has too much play in the locking mechanism.

### REMEDIAL ACTION

1. Clean the towball and friction pads by lightly rubbing the surface (100-120 grit emery paper)
2. Lubricate the draw-shaft sleeve via the grease nipples. In addition, push the gaiter forward and grease (DIN 51 825 KTA 3K) the exposed part of the shaft (Fig, 7).

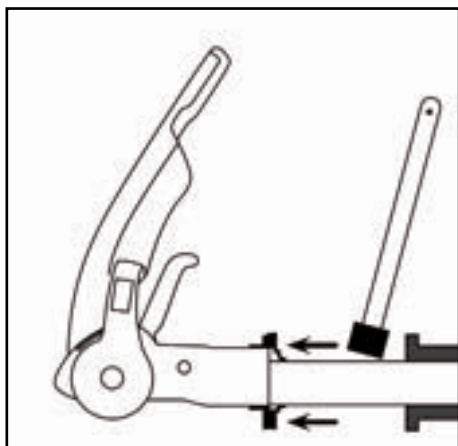

FIG. 7.

3. Visit a specialist workshop to have the ball holding area checked for damage and the locking mechanism for function. If necessary, change the towball.

### STORING

To reduce the possibility of contamination of component parts of the AKS 3004 the stabilising handle should be closed.

### TOWING BALL

The automobile towing ball should measure 50mm maximum and 49mm minimum diameter (DIN 74058). If the ball is below 49mm diameter it should be replaced immediately.

**OVERRUNNING DEVICE**

The device housing is packed with grease on assembly, but will require periodic maintenance to ensure smooth operation of the braking system.

- Re-grease the shaft bearings via the grease nipples provided at 3,000 mile intervals, and before storage.
- Ensure correct functioning of all pivot pins and levers, and oil regularly.
- Ensure correct functioning of handbrake ratchet and oil regularly.

**JOCKEY WHEEL**

Lubricate wheel and screw thread periodically with grease.

**BRAKE LINKAGE**

All moving parts should be lubricated periodically to ensure their satisfactory operation.

**CORNER STEADIES**

The screw and pivot pins should be lubricated periodically to ensure their satisfactory operation.

**BRAKING SYSTEM ADJUSTMENT**

(At 500 miles, then every 3,000 miles or 1 year)

1. Ensure the towing shaft with coupling heads is pulled fully forward.
2. Release the handbrake to the fully off position. If the handbrake will not go down the whole way because of the fairing or any other obstruction then the fairing must be cut away and/or the obstruction removed to achieve this desired position. It will not be possible to set up the braking system properly when the handbrake is not in the fully off position (fig. 8).
3. Jack up one side of the caravan (see Jack Operation Instructions).
4. Remove the inner plastic bung from the backplate to expose the "star-wheel" adjuster access (fig. 8).

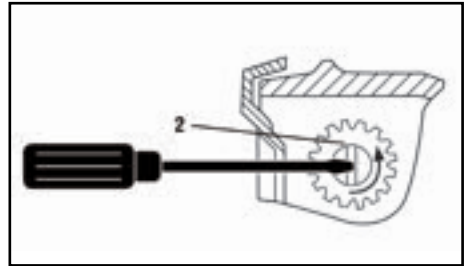
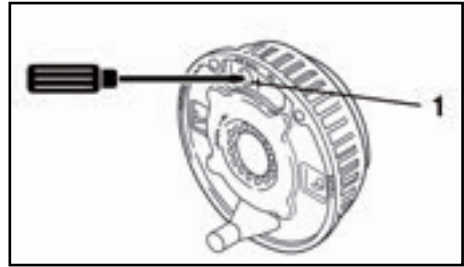

FIG 8.

5. Rotating the road wheel in the forward direction (never backwards), adjust the star-wheel with a suitable screwdriver in the direction of the arrow embossed on the backplate until there is resistance in the wheel rotation (fig. 8).
6. Slacken off the star-wheel adjuster until the road wheel turns freely in the forward direction (fig. 8).
7. Check the adjustment at the end of the brake cable where it is secured to the abutment (bracket) welded to the centre of the axle. When the inner cable is pulled out it should extend between 5 and 8 mm. (On tandem axles a double abutment is fitted to the front axle only).
8. Repeat for other wheel or wheels.

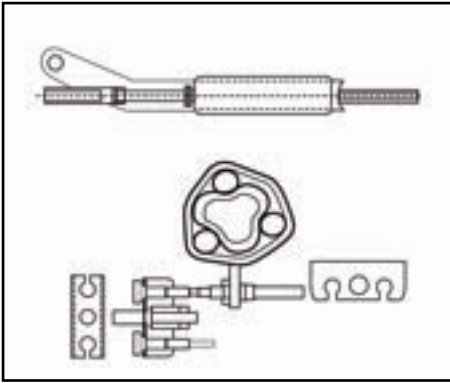

FIG 9.

9. Ensure the balance bar (compensation) is being pulled evenly. This bar (double on tandem axles) should always be paralleled with the axle tube when pulled. Adjust M8 lock and ball nuts, if necessary, to achieve correct parallel position (Fig. 9)

10. Check the brake rod support bracket (fixed to the floor) is supporting the brake rod evenly. The brake rod must always run straight, never bent or curved under any fittings. On tandem axles, using the double balance bar, a brake rod support tube (Part No. 228827) must always be fitted on the end of the brake rod, passing through the centre aperture on the abutment.

11. Remove the slack in the brake rod by adjusting the long ball nut to the rear of the balance bar, ensuring the overrun lever makes contact with the end of the towing shaft. Over-adjustment to the long ball nut (Fig.10) could induce movement of the inner brake cable, reducing the effective clearance of the brake shoes. If the overrun lever will not make contact, it is possible the two lock nuts, forward of the spring cylinder, are incorrectly adjusted. Loosen the nuts and adjust the brake rod as above (Fig. 8).

12. Adjust the two locking nuts, forward of the spring cylinder (Fig. 9) (on some chassis a single Nyloc nut is used) to give 1mm of clearance on the spring cylinder. This cylinder (the energy store for the handbrake operation) must be able to rotate only, not slide on the brake rod. (See Fig. 9) If the overrun assembly is fitted with a gas strut handbrake then no spring cylinder is fitted, ignore this paragraph.

13. Correct adjustment of the linkage is checked by operating the handbrake lever so that when the second or third tooth is engaged, a slight braking force is felt on the road wheels.

14. Over-adjustment of either the wheel brakes or linkage will result in difficult reversing causing the wheels to "lock-up".

15. When parking, the handbrake lever must always be engaged into the fully upright position (90°). This is to compress the spring within the spring cylinder and thereby create an energy store, which will automatically engage the brakes further should the caravan move.

16. If difficulty is experienced in this operation, try easing the caravan backwards with one hand while engaging the handbrake fully with the other. This manoeuvre should not be attempted on a rearwards facing slope. In this case wheel chocks should be used combined with the handbrake.

17. Finally, if the road wheels have been removed, re-tighten using a calibrated torque wrench to 130Nm (on all M12 wheel bolts - in sequence, i.e. North, South, East, West not clock or anticlockwise.) DO NOT overtighten this is just as dangerous as to undertighten, as this can distort the wheel rims. Avoid the use of power wrenches.



The torque settings should be re-checked after 50km/30 miles. Wheel bolts should never be lubricated.



In order to operate the AL-KO braking system correctly adequate traction of caravan wheels is required when reversing. Therefore surface conditions that would result in a lack of traction should be avoided.



Care should be taken when traversing ramps or other obstacles in order to prevent damage to the caravan under gear. When approaching such obstacles reduce towing speed appropriately.



### CHASSIS LUBRICATION POINTS

1. Grease the drawbar in the area of the bellows.
  2. Grease the bearing bush through the grease nipples on the housing and the cartridge.
  3. Grease the pivot bolt of the overrun lever and handbrake levers through the grease nipple.
  4. Grease the joint of the brake rod and fitting.
  5. Oil the joints of the spring cylinder in the handbrake lever.
- Lubricant type: Multi-purpose grease to DIN 51825 KTA 3K4.

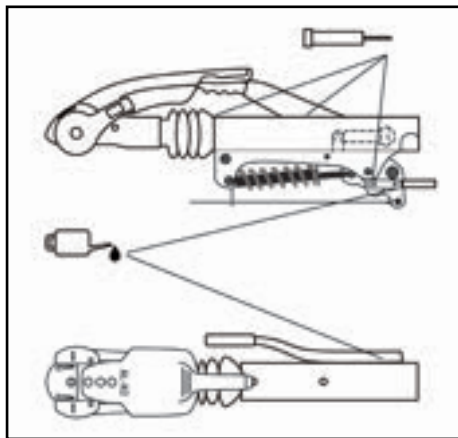

### AL-KO ATC TRAILER CONTROL SYSTEM

AL-KO ATC is an electronic, emergency control system for caravans and trailers. It automatically recognises critical swinging motions and applies the caravan brakes accordingly to regain control of the caravan and car.

### SAFETY INFORMATION



AL-KO ATC is a passive safety product that activates the braking system on the caravan in unsafe driving conditions.

The driver has a responsibility under law to ensure that the elements of towing safety are met, including driving within the legal speed limit, consideration of road, weather and other traffic conditions, also the correct loading and coupling of the caravan.

### OPERATING INSTRUCTIONS

After coupling the caravan correctly to the towing vehicle, connect the 13 pin plug to the towbar.

Upon connection, ATC will carry out an initial self test and the LED light on the front fairing will light up on RED. During the self test, the sound of the push rod moving inside the ATC can be heard. When the self test is complete, the LED will turn GREEN or flashing GREEN to signal that the ATC is active.

If the LED does not change to GREEN, then the ATC is not functioning correctly.

Prior to commencing any journey, ensure that the caravan lighting is fully operational and check the vehicle is loaded appropriately, the nose weight and tyre pressures are correct, and confirm that the caravan is coupled to the vehicle with the breakaway cable correctly applied.

Always re-check that the ATC LED is green after any interval during a journey, such as a service station break.

Always disconnect your ATC once parked on a ferry, ensuring you reconnect before you restart the engine and leave the ferry. This will ensure that your battery is not run down during the crossing.

Should you experience any issues with your ATC please contact AL-KO or the supplying Bailey retailer.

### SPARE PARTS

Spare parts are safety critical parts! For this reason when fitting spare parts in our products we recommend the use of original AL-KO parts or those parts that we have explicitly approved. The reliability, safety and suitability of parts designed especially for our products have been determined using a special test procedure. In spite of constantly monitoring the market we are unable to assess or vouch for other products.

If repair work or servicing is required AL-KO have a large network of AL-KO service centres throughout Europe. A list of service centres can be requested direct if required. Please bear in mind that repairs should only be carried out

by trained and qualified workshops/personnel. To establish the correct spare parts the service centres need the ETI number (spare part identification number).

### CHASSIS MEMBERS

The recommended tow vehicle coupling height is 385mm +/- 35mm from the ground to the centre of the ball.



Off road vehicles are exempt from this towball height specification.

Manufactured from high quality steel, the chassis has extra deep sections to provide strength at points of maximum stress. Large elongated holes are punched in the longitudinal and towbar (A frame) members, to reduce weight to a minimum. Each hole incorporates a return flange to maintain the required strength and provide rigidity in the extra deep sections.

The chassis frame is of a bolted construction which, should the need arise, allows replacement of individual parts.

The chassis is hot dipped galvanized. This is regarded as one of the best forms of corrosion protection. It does, however, require maintenance in certain circumstances. When new, the chassis is of a bright and shining appearance. As the galvanizing cures during the initial 2- 3-month period, this will gradually change. During this curing period the surface should be protected to avoid possible wet storage stain, a soft, light coloured, porous, oxidation layer. If the chassis members are in contact with any salt deposits from roads they should be washed off immediately with a high pressure washer. Salt attracts moisture allowing the surfaces to remain wet. This prevents curing and also allows formation of wet storage stain.

It is recommended that the chassis be washed off, using a pressure washer, on an annual basis (particularly after winter usage) to avoid undesirable build up of salt and dirt deposits.



Do not spray or direct wet jet into the floor vents and other openings. Do Not pressure wash the sides or roof of the caravan to avoid ingress of water through roof lights, windows and fridge vents.

The galvanized chassis should not be painted or subjected to any other protective treatment. Should the galvanizing become superficially damaged exposing the steel core, then it should be cleaned and treated with a cold galvanizing spray. Damage to chassis members through impact etc. must not be straightened or welded. Damaged chassis members must be replaced.

### DRILLING OR WELDING OF PARTS OR ACCESSORIES



This chassis is designed and built to precise tolerances and must not be drilled or welded.

### INDEPENDENT SUSPENSION

The AL-KO rubber suspension is designed and developed to suit all types of road conditions and is maintenance-free. Three rubber elements are contained within a hexagonal axle tube. These provide suspension and have inherent damping characteristics. (Only the hubs and wheel brakes require attention, see axle booklet Part No. 580458.)

### COUPLING HEAD

The ball couplings are entirely automatic in operation and designed for one-hand operation to suit the 50mm international ball recommended by the British Standards Institution, National Caravan Council and the Society of Motor Manufacturers and Traders.

### BRAKE DRUM/HUB ASSEMBLY

The Euro Axle fitted to your Bailey caravan comes complete with maintenance-free wheel bearings greased and serviced for life. Adjustment is not required during the design life of the sealed bearing (100,000 km).

If replacement of the brake drum or shoes is required, this must be carried out by authorised AL-KO Service Centres. Specialist tools and equipment are required. The rear hexagonal bolt covered by a black plastic cover must NEVER be touched.

## TRACKER MONITOR AND CARAVAN ALARM

Dependant upon model, your caravan may have been fitted with a TRACKER Monitor and Caravan Alarm.

Using VHF technology, the police can track a stolen caravan even if it's being transported or hidden in a lock-up or a shipping container.

### ALARM OPERATING INSTRUCTIONS

The Caravan Alarm system detects external caravan movement such as shaking and tilting, lifting and towing. Internal movement is detected by a passive infrared sensor (PIR).

If the alarm is triggered, the siren will sound. The TRACKER Monitor system, once armed via the remote control, detects caravan motion. If the TRACKER Monitor system is triggered, TRACKER will be alerted. TRACKER will call you and, if there has been a theft, start the recovery process.

TRACKER Monitor requires a setting period of 2 minutes before becoming fully operational. Should the alarm not be armed or not be operational at any point (e.g. as the result of a flat remote control battery), the TRACKER Monitor system will still continue to operate for tracking and recovery purposes but no automatic alert will be given to TRACKER.

### To ARM

Press the button on the remote control once and the siren will beep twice.

After 45 seconds the alarm will be armed.

The siren will be triggered if the caravan is towed, moved, tilted and lifted onto the back of a trailer.

The siren will sound for five minutes unless stopped by the user. The siren can also be triggered by the passive infrared detector (PIR).

### To DISARM

Press the button on the remote control once.

The siren will beep once and the alarm will disarm. If already sounding, the siren will be silenced.

The alarm is supplied with one PIR and two remote control units. Additional units may be ordered from your Bailey retailer.

### WINTER STORAGE

Before storing the caravan for winter, please ensure that the leisure battery is fully charged. Dependant on the battery's capacity and age, it will require recharging at intervals of between three and six months.

### What do I do if my caravan has been stolen?

Report the theft to the local police authority then contact TRACKER on the theft line. On confirmation of the theft details, the Tracker system will be activated and the police will start to track your caravan. Once the police have located your caravan TRACKER will arrange for a uniformed guard to stay with it until TRACKER recovery partners arrive to pick it up and return it to you.

### I am changing my caravan and the new one does not have a TRACKER system, can I take it out and fit it to my new one?

No, it is not possible to transfer it to another caravan.

### Will my TRACKER system work in France?

Yes the TRACKER system works in England, Scotland, Wales, Northern Ireland, France, Spain, Portugal, Italy, Netherlands, Luxembourg and Poland

### What happens to my TRACKER unit if my caravan battery is disconnected?

The alarm part of the TRACKER Caravan system is powered from the leisure battery so it will not operate if the leisure battery is disconnected. The TRACKER Monitor system has its own external 12 volt supply that will last up to 6 months with the leisure battery disconnected but it is advisable to keep the leisure battery connected and charged at all times

### Can I have a second PIR fitted?

Yes, you can have any number of PIRs fitted. They will need to be programmed to your alarm, please refer to your Bailey retailer.

### Does the PIR cause the Tracker system to go off?

No, the PIR will only make the siren sound. It will NOT trigger the TRACKER system.

**The PIR has a red light on it, can I switch it off?**

No, the warning LED indicates that the unit is working and cannot be switched off.

The PIR is permanently active as indicated by the periodic flashing of the red LED. However, the alarm will only trigger if it is in the armed state.

**I keep dogs in my caravan and the alarm keeps going off, can I switch off the PIR?**

No, this is not a feature of the system and will always be working if you have armed the alarm.

**The PIR is making a funny noise why?**

The PIR has a low battery warning tone. If this is sounding, the batteries require replacement.

**What battery is in the PIR and where can I get one?**

It uses 2 x AAA batteries. These are commercially available.

**I pressed the remote control button and nothing happened. Why?**

Did the small red light on the remote control illuminate? If not try changing this battery with a GP23A type battery.

Have you got your leisure battery connected and charged? If not, charge the leisure battery for over 24hours.

**What battery do I need for the remote control?**

GP23A type battery. These are commercially available.

**I have lost my remote control. What can I do?**

You will need to contact your Bailey retailer to purchase a replacement remote control. They will de-program your old remote from the alarm (it will then not work again) and at the same time re-program the alarm to the new, replacement remote control.

**I only have one remote control. Can I obtain more?**

Yes, your Bailey retailer will be able to sell you an additional remote. Up to 5 can be programmed and linked to the system.

**My Bailey caravan does not have a Tracker fitted to it can I have one retrofitted?**

Yes, your Bailey retailer will be able to sell you an after-market Tracker system.

## WATER SYSTEMS: WITHOUT AN ON-BOARD WATER TANK

### WATER SUPPLY

Various models are supplied with a 12v submersible pump, controlled by a pressure switch. This pump is designed to simplify the connection of an outside water supply to the caravan system. The pump comprises of a wall socket, plug, hose and submersible pump. The plug and socket combine both the water and electrical connections and are designed for pumping fresh water into the caravan.

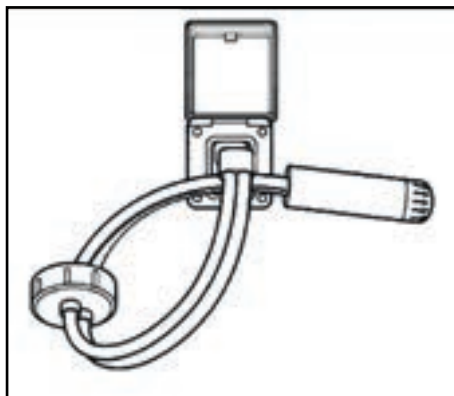

### DRAIN VALVE

Near to the water heater within one of the front bunks you will find the drain valve (pictured below). This valve is used to drain your caravan of all water prior to being in transit.

Before attempting to fill your water system you should always ensure the yellow switch is in the horizontal position (position e). When you wish to purge the system of water (prior to being in transit) you should place the yellow switch in the upright position (position f). The water system will now purge any excess water.

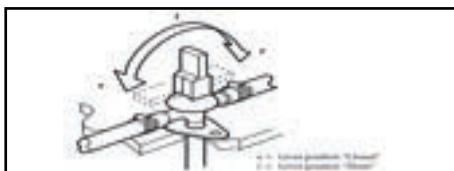

### SETUP

1. Open one cold tap (e.g. the kitchen sink).
2. Place the pump into the aqua roll (pictured below).

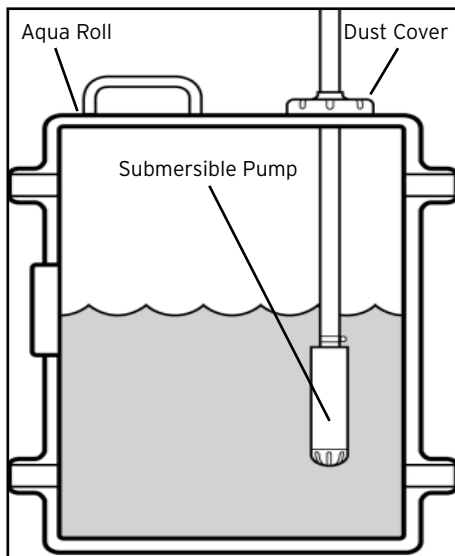

3. Insert the plug end of the pump into the wall socket and close the flap to lock plug in place (pictured below)

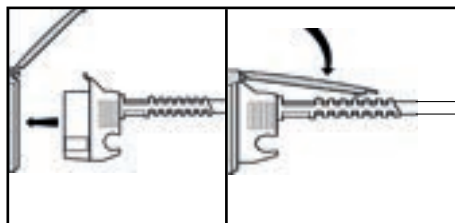

4. Fit the dust cover over the opening in the aqua roll (the dust cover should not be air tight to the water container as air must be allowed to enter the container to replace the water being pumped out).
5. Switch on 12 volt supply at the main control panel (isolator switch inside caravan).
6. Water will flow from the open tap expelling any trapped air in a few seconds.
7. Turn off the tap.

**REMOVING THE PUMP**

- Switch off the 12v supply at the control panel (isolator switch inside caravan).
- Pull the plug from socket.
- Shut the flap.



Do not run pump dry or use the pump in water temperatures above 40°C (100°F)

It is best practice to stand the pump vertically in the tank.

**ROUTINE MAINTENANCE**

The micro-switch or phosphor bronze contacts can be removed for inspection or replacement.

Ensure the hose adaptor O-ring and the socket in the housing are kept free from dirt.

Use only silicone or water-based lubricant on the inlet nipple O-rings on the socket.

Service the inlet socket annually.

**Beginners Guide Video,  
Scan to view:  
Water system**



## WATER SYSTEMS: WITH AN ON-BOARD WATER TANK

### WATER SUPPLY

Various models are supplied with an on-board water tank and inbuilt submersible pump as well as an external 12v submersible pump controlled by a pressure switch. The external pump can be used to supply water directly to the caravan from an outside water supply or it can be used to fill the on-board tank in the same way as described in the previous chapter.

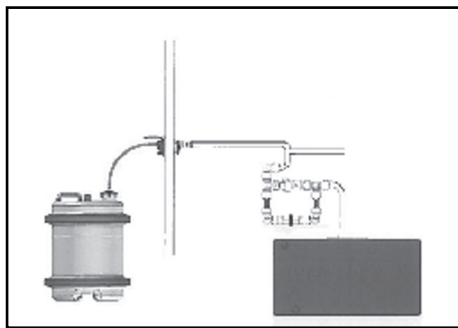

### FILLING THE ON-BOARD TANK

1. Complete steps 1-7 on the previous pages.
2. Switch off the 12v supply for the on-board pump at the main control panel.
3. Locate the 2-way valve in one of the front bunks. See below.

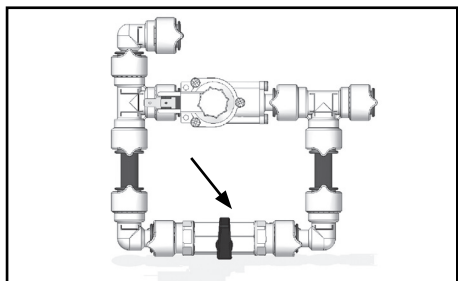

4. Turn the 2-way valve to the open position shown below.

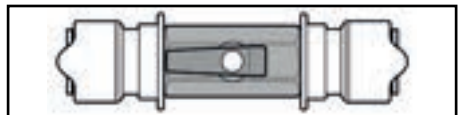

5. Switch on the 12v supply for the external pump at the main control panel (EXT). This will fill the on-board tank.
6. When the water runs from the overflow pipe below the caravan, switch off the 12v supply for the external pump at the main control panel.
7. Return the 2-way valve in the front bunk to the closed position shown below.

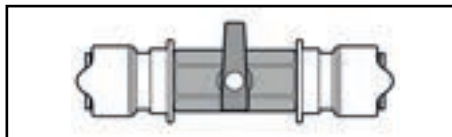

### INTERNAL SUPPLY

1. Open one cold tap (e.g. at the kitchen sink).
2. Locate the 2-way valve in the front bunk.
3. Ensure the 2-way valve is set to the closed position shown below.

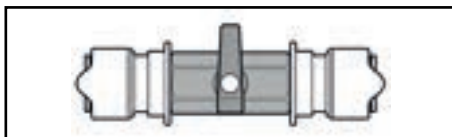

4. Switch on the 12v supply for the on-board (INT) pump at the main control panel. Water will flow from the open tap expelling any trapped air in a few seconds.
5. Turn off the tap, the system is now ready for use.



Do not run pump without water or use the pump in water temperatures above 40°C (100°F)

The pressure switch is sensitive to drops in battery voltage. As the voltage falls, should the switch need adjustment, turn it anti-clockwise. Rotary switch shown below.

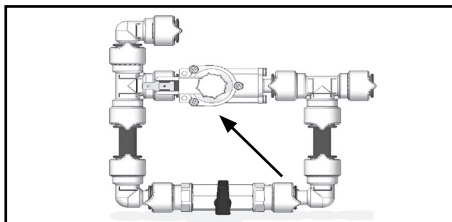



**TANK DRAIN OPERATION**

The tank must be drained completely prior to travel.

1. Locate the 2-way valve attached to the side of the on-board tank.

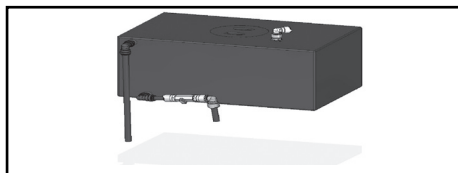

2. Turn the 2-way valve to the open position shown below.

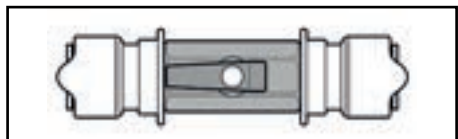

3. The water will drain from the tank beneath the caravan.
4. Once all the water has been drained turn the 2-way valve to the closed position shown below.

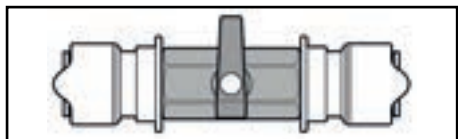

To fully drain the water system see previous section entitled 'Drain Valve'.

**DRAINING AND WINTERIZATION OF THE WATER SYSTEM**

Bailey caravans may be in use all the year round, however, when not in use (even for short periods) this procedure should be followed.

One night in freezing temperatures is all that is required for expensive, permanent damage to occur within the water system.

Ensuring that all water is removed from the caravan's pipework, taps and appliances will reduce the risk of frost damage occurring. Frost damage can occur when water left in the

system freezes and expands. This causes the pipework to split, crack or burst.

**PROCEDURE**

1. Ideally position the caravan so the drain valves are the lowest point, e.g. tilt the caravan.
2. Switch off the 12v supply for all pumps at the main control panel.
3. Open all taps/mixers to the mid position, including the external shower (if fitted).
4. Remove the shower handset (including the external shower if fitted) and shake the water out.
5. Open the water heater drain valve and leave open.
6. Open the on-board tank drain valve (if present) and leave open.
7. Where grey waste tanks are fitted, remove all sink plugs and open the drain tap.
8. Open all other drain points (if present).
9. External water components - shake water out of pump/aqua-source and store inside the caravan.

The shower tray cannot be expected to drain fully, some residual water may remain which will require 'mopping up'.



It is essential that the level of ceramic ball mixer taps is fully raised and in the central position. Failure to do this will not allow both the hot and cold water system to fully drain and will result in frost damage.



Frost damage cannot be claimed under warranty.

**ON INITIAL SETUP AFTER WINTERIZATION**

- Check all the plumbing connections.
- Sterilise the water container and flush the system through with a sterilising fluid.
- It is recommended that the water system is checked during the annual caravan service.

**STERILISING**

When cleaning the water system at the start or end of the season it is advisable to use non-chlorine-based sterilising fluid.

Flush the system thoroughly to remove the effective fluid traces.



Bailey states that you must fully drain down all fluids before travelling (with the exception of the central heating system). Any fluids within the caravan whilst travelling will effect your payload allowance.

## WATER SYSTEM TROUBLESHOOTING

FAULT	CAUSE	POSSIBLE SOLUTIONS
Pump will not run	No power to pump	Check power supply Check the mains isolator switch is on Check the pump isolator switch is on
	Fuse has blown	Replace fuse (do not exceed recommended fuse size)
	Blockage in pipework	Check pipework for kinks Check pipework for blockage
Pump runs but no water appears	No water available	Check water tank is not empty Check filter cap is not blocked
	Water leaking from system	Check pipework and connections for leaks and repair as necessary Check water system drain plugs are closed
Pump runs but will not switch off	Water leaking from system	Check pipework and connections for leaks and repair as necessary Check water system drain plugs are closed
	No water available	Check water tank is not empty Check filter cap is not blocked
Pump cycles on and off periodically when all the taps are closed (normal with partially opened tap)	Water leaking from system	Check pipework/fittings for leaks and repair as necessary Check water system drain plugs are closed
	Pressure switch	Check pressure switch settings
	Power supply to pump	Check battery is not discharged
Low flow	Blockage in pipework	Check pipework for kinks Check pipework for blockages
	Power supply to the pump	Check battery is not discharged
	Pipework/connections crushed due to over tightened jubilee clips	Replace damaged connections
	Water leaking from system	Check pipework/fittings for leaks and repair as necessary Check water systems drain plugs are closed

## ADJUSTING YOUR PRESSURE SWITCH

Your pressure switch is factory set and should not normally require adjustment. However, if adjustment is required due to the power supply voltage varying from the previous setting, either because of battery drainage or higher voltage being supplied when the battery charger is operating or in the event that your pump doesn't switch off when you close the taps or pulses on and off rapidly when the taps are fully open.

You should follow the below guidelines to re-adjust the pressure switch setting.

### Which Pressure Switch do you have?

#### In-Line Pressure Switch

Internally located within the water system pipework

#### Integral Pressure Switch

Located on the back of the water inlet socket



### Pressure Switch Setting

Ensure the system, including the heater is full of water and all taps are closed. Refer to your user manual.

Tighten the adjusting screw clockwise until the pump comes on. (For integral socket based pressure switches, first loosen the pressure switch locknut in an anti-clockwise direction.)

Open any tap until you have a smooth flow of water, then close the tap. You should hear the pump running and the pump running light if fitted will be on.

Return to the pressure switch and turn the pressure switch adjustment screw slowly anti-clockwise until the pump has stopped. Turn the screw a further half turn (180 degrees) anti-clockwise.

Check for correct operation by opening and closing all taps individually. The pump should turn on when the cold tap is opened and switch off immediately when the cold tap is closed. NB. There will normally be some pulsations at low flows.

The hot side may take about 10 seconds to react (both on and off) due to cushioning effect in the water heater.

For integral socket based pressure switches, carefully tighten the locknut until it is tight keeping the adjustment screw in position.

#### THREE GOLDEN RULES:

1. NEVER allow the pump to run dry
2. NEVER allow the pump to run continuously for more than 15 minutes
3. The pump assembly MUST be unplugged BEFORE putting the pump back into the refilled water container.

If setting of the pressure switch is still not correct you may experience:

Pump running continuously, even with tap closed. If undiscovered, could result in pump failure and flat battery. Most likely causes are that present voltage is significantly lower when last adjusted, or water container is empty.

**CURE: Re-adjust switch or refill container**

Pump does not run at all. If not due to blown fuse or faulty connections, then most likely cause is excessive continuous running (see above) **CURE:**

**Replace pump and re-adjust switch**

Pump runs intermittently ON, OFF, ON, OFF etc. Seen as pulsing flow from tap, or as inability to set constant water temperature, water goes hot, cold, hot, cold instead of constant warm. Most likely cause is that present voltage is significantly higher than when last adjusted.

**CURE: Re-adjust pressure switch, if problem persists add a Whale Surge Damper (WS7205).**

Pump runs very noisily but does not pump water. Likely to occur after water container has been refilled. Pump is air-locked and is fighting to get air out and water in.

**CURE: Unplug from the socket, allowing pump to flood, and reconnect by plugging in again. The correct sequence when refilling the container is to unplug, put pump into container, then reconnect.**

Pump continues to run for up to 30 seconds after tap is turned off. This is not a problem. This is a characteristic of pressure switch systems caused by the dampening effect of the hot water heater or surge damper on the cold side.

If after following these procedures the system continues to pulse when all taps are closed there may be a leak in the system.

Please contact Whale Support for further guidance.

## THE GAS SYSTEM

All gas appliances fitted within your Bailey caravan are suitable for operation on both butane and propane without the need for adjustment. However gas type specific regulators must be used.

### GENERAL INFORMATION

Gas cylinders: Bottled Liquefied Petroleum Gas (LPG) is the most convenient portable source of fuel for your caravan.



The gas system meets BS EN 1949 and should only be modified by a qualified person.

Never use portable cooking or heating appliances, other than electric heaters that are not the direct radiant type. Direct radiant types are a fire and asphyxiation hazard.

### TYPES OF GAS

#### BUTANE

- Butane is supplied in the UK in green or blue bottles.
- Continental bottles usually have a male left hand thread similar to but not identical with UK Butane.
- Butane is suitable for use at temperatures down to 2°C but will not work below that temperature.

#### PROPANE

- Propane is supplied in red, or partially red bottles that have a female left hand threaded connector.
- Scandinavian countries use the same connector.
- Germany and Austria supply propane with a male connection.
- Propane will work at temperatures as low as -40°C and is therefore suitable for all winter caravanning.

### SAFETY

- Make sure that heating, cooking appliances and gas cylinders are switched off before you move the caravan.
- All gas appliances in your tourer can have their gas supply individually isolated by turning off the relevant tap. The taps are located either on the centrally positioned gas manifold or directly beside the appliance. The manifold will look similar to the adjoining picture.

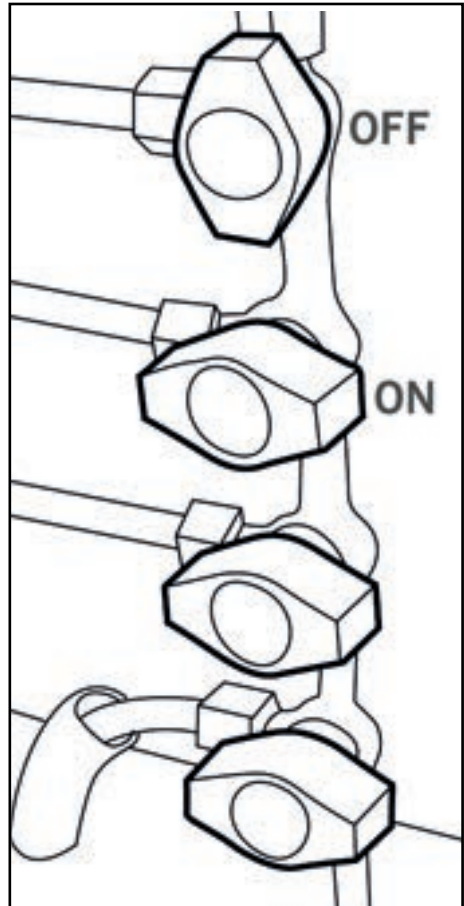

Regularly check flexible gas hose, joints and connections for tightness.

Finally make sure that each gas appliance is working efficiently to the recommendations of the appliance manufacturers.

### THE REGULATOR

The regulator is a governing device which adapts the bottle pressure to one that suits the equipment in the caravan.

Your caravan is fitted with a regulator as standard. This is located in the caravan gas box. The gas regulator has a working pressure of 30m bar and is suitable for both propane and butane liquefied petroleum gas. There are dedicated hoses available for different types of gas bottle.

## PLEASE MAKE YOURSELF AWARE OF THE FOLLOWING



Some industrial LPG appliances operate at high pressure and require a "high pressure" regulator. This often has an adjusting handle on it. Never use such a regulator on a caravan.

- Propane and butane gas regulators are not interchangeable.
- Always ensure that the gas system is inspected/maintained every 12 months.
- In the event of a fire ensure all occupants evacuate the caravan via the nearest escape route.
- If you suspect a gas leak then immediately turn off the supply of gas, then turn off the gas valve on the gas bottles. When this has been completed the system must be inspected by a qualified person.
- Never use gas bottles located outside the caravan gas box.
- Do not use any gas extension hoses.
- When using a gas barbecue always ensure gas appliances are suitable for use at 30mbar.

## CHANGING GAS CYLINDER

1. Ensure the cylinder is empty.
2. Turn off the regulator tap located near to gas regulator.
3. Turn off cylinder valve and all gas appliances.
4. Remove the gas hose regulator from the cylinder.
5. Release retaining strap.
6. Remove cylinder from gas locker and stand on ground.
7. Fit plastic protective cap to the cylinder.
8. Before placing the full cylinder in the cradle ensure that the tray is clean and free from any debris. Cleaning should be carried out with only warm soapy water.
9. Place cylinder in the cradle within the gas locker.
10. Remove plastic protector from cylinder.
11. Connect the gas hose.
12. Connect retaining strap.
13. Turn on cylinder valve and systematically relight appliances as required.

## GAS SAFETY ADVICE



LPG is poisonous. There is a danger of death if all air and oxygen is excluded. Ventilation holes must be kept clear at all times and must not be obstructed. Manufacturers have given LPG a distinct smell in order to identify leaks.

## GAS LEAKS

If the smell of gas becomes apparent, the supply should be turned off at the cylinder immediately.

Extinguish naked flames including cigarettes and pipes.

Do not operate electrical switches.

Open all doors and windows to disperse any escaping gas.

Butane/propane gas is heavier than air; any escaping gas will therefore collect at a low level. The strong unpleasant smell of gas will enable the general area of the leak to be detected.

Check that the gas is not escaping from an unlit appliance. Never check for leaks with a naked flame. Leak investigation should be carried out using a leak detector spray.

Do not operate any electrical apparatus whatsoever, especially light switches. If the leak is not obvious, the caravan should be evacuated and a competent service engineer consulted.

Avoid naked lights when connecting or changing a cylinder. Ensure the gas valve is turned off.

Regularly inspect the flexible gas hoses for deterioration and replace as necessary with approved hoses (all hoses should be replaced before the expiry date marked on the hose or after a maximum of five years).

Keep gas bottle containers outside (and protected against frost). If they must be kept inside make sure they are well away from heat.

**VENTILATION**

All ventilation complies with EN 721. Vents should not be obstructed in any manner as this could lead to insufficient ventilation. In this case the atmosphere becomes depleted of oxygen which leads to the formation of the highly poisonous gas Carbon Monoxide. Carbon Monoxide is odourless, colourless and tasteless and could rapidly cause unconsciousness leading to death with little or no warning prior.



Under no circumstances should the caravan's ventilation be blocked or obstructed in any way.

High level ventilation is via the roof lights. Low level ventilation is via the vents in the floor in the caravan living area. With multi-berth layouts the rear sleeping compartments have their own low level ventilation. Please consult your caravan retailer for its location.

The mesh screens fitted should be kept free of obstructions by dust, leaves, insects etc. Inspect regularly and use a brush and soapy water as necessary. It may be necessary to remove the weather shield located on the underside of the floor of the caravan to gain access for cleaning.

All flue installations should be inspected once a year, throughout their life, for corrosion. Flues should be replaced if any sign of degradation is found. Ensure that the replacement is of an approved type. Check that the external seal is seating correctly and the locknut is fully tightened.



Do not make any additional openings in the floor.



Appliances such as cookers with naked flames should never be used for room heating.



No appliance shall be used inside when being connected to the external BBQ socket.

**GAS BBQ POINT**

The external gas BBQ point should never be used as a gas inlet it should only ever be used as a connection outlet.



Please be aware that contaminated gas will cause regulators to become damaged and fail. Any such failure caused by contaminated gas will not be covered by your warranty.



Please keep the BBQ unit at least 1.5m from the caravan to prevent any heat damage to the vehicle

**Beginners Guide Video,  
Scan to view:  
Gas system**



## THE 230v ELECTRICAL SYSTEM

As in the home, care must be exercised when using mains electricity.

### UPON ARRIVAL AT CARAVAN SITE

When connecting the caravan installation to the mains supply:



When connecting caravan to the mains bollard, ALWAYS connect to the caravan first and then to the site bollard.

1. Check the mains supply is suitable for your installation and appliances.
2. Check that your installations will be properly earthed.
3. Never accept a supply from a socket outlet or plug having only two pins, or from a lighting outlet.
4. Check that any residual current device (RCD) or earth leakage circuit breaker in the mains supply to the caravan has been tested within the last month. After connection to site supply, test again.
5. Make sure that the switch at the site supply point is off.
6. Make sure that the caravan RCD unit is switched off.
7. Remove any cover from the electricity inlet provided on the caravan, and insert the connector of the supply cable.
8. Remove any cover from the socket outlet provided at the site supply point, and connect the plug at the other end of the supply cable.
9. Switch on the mains switch at the site supply point.
10. Switch on the caravan RCD unit.

In cases of doubt, consult the site owner or their agent.



When disconnecting caravan from the mains bollard, ALWAYS disconnect from the site bollard.

### UPON LEAVING THE CARAVAN SITE

1. Switch off the site supply.
2. Switch off the caravan RCD unit.
3. Disconnect the pitch lead.
4. Replace the cover of the socket outlet at the site supply point. It is dangerous to leave the supply socket or supply cable live.

If you encounter difficulty, consult an approved electrical installation contractor (which may be the local electricity board). It is dangerous to attempt modifications yourself.

Every 12 months, the caravan electrical installation should be inspected, tested and a report on its condition obtained as prescribed in the Regulations for Electrical Installations, published by the Institute of Electrical Engineers.

### OVERSEAS CONNECTIONS



Connection to a mains voltage supply overseas requires particular attention.

- Care must be taken when connecting supplies abroad since the supplies can be reverse polarity.
- The significance of reverse polarity is that when equipment is switched may not be electrically isolated.
- The only certain way of making equipment safe is to unplug it.
- A means of checking the polarity of the mains supply when overseas is useful.
- There are several proprietary makes of equipment available for this purpose. If it can be achieved, it is preferable to connect live to live, and neutral to neutral to maintain full electrical protection.
- Check all caravan equipment is set up to accept the site supply before actually switching on.

### MAINS UNIT (PDU)

The mains unit replaces the conventional fuse box.

The unit gives overload and earth leakage protection for the 230v electrical supply in your caravan.

### FOR NORMAL OPERATION

- All switches on the unit need to be set to the ON position. The switches on the left of the unit are known as MCBs (miniature circuit breakers). These take the place of the conventional fuse and are more convenient.
- In the event of a fault the MCB trips/ automatically moves to the OFF position.
- After elimination of the fault the MCB can be re-set by switching to the ON position.



- If an earth fault develops or a person was to touch a live piece of equipment the leakage of current to earth should immediately operate the RCD (residual current device) and "trip" the main switch, to the OFF position.
- This switch is only resettable after elimination of the fault.
- To re-set, operate the switch as for MCBs every time you connect to a site supply the RCD should be checked by operating the test button marked "T". The unit should immediately switch to the OFF position. If the unit does not switch off then a qualified electrician should be consulted.



Always disconnect the electrical connector between the towing vehicle and the caravan before connecting a 230v supply to the caravan and before charging the caravan battery.

It is possible that all of the 230v mains electrical equipment may not be operated simultaneously. A typical UK caravan park mains hook-up point provides a maximum output of 16 amps and on some continental sites the available output may be as low as 5 amps. If your loading exceeds the site supply it may trip the park's circuit breaker.

Please check the available mains output with your site operator.

If the unit does switch off, the test is complete and the switch can be reset restoring the supply back to normal.

The following items need to be added together if used simultaneously.



Having too many appliances switched on at the same time will trip the MCB. This is a safety measure.



It is essential that connections are made exactly as shown. If terminal markings are not in accordance with the diagram they must be ignored. If in doubt consult a qualified electrician.

230V mains equipment typical consumption figures:

Fridge	0.5 amps
Colour TV	2.5 amps
Charger	1.0 amps
Microwave	10.0 amps
Air conditioning	4.0 amps
Blown/convection air heating	8.7 amps
Kettle (2000w)	8.7 amps

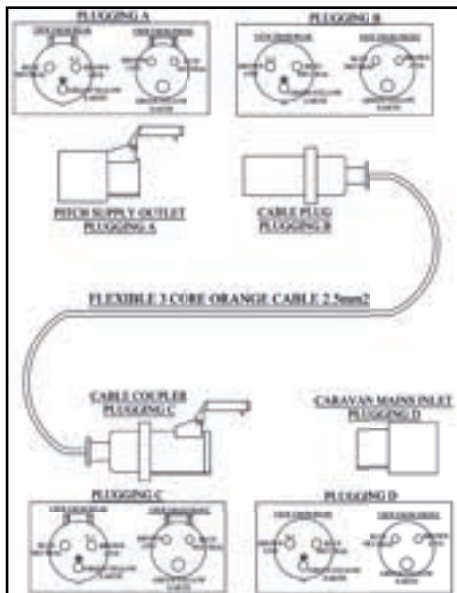

**Beginners Guide Video,  
Scan to view:  
Electrical system**



## THE 12v ELECTRICAL SYSTEM

Your caravan is fitted with a 12v charger as standard. This converts the 230v AC supply into 12v DC. It enables the 12v equipment in the caravan to function and also charges the caravan leisure battery when plugged into a site hook up. A fully charged caravan leisure battery should read 13.8 volts on the voltmeter mounted in the control panel. The charger is capable of charging leisure batteries and will not overcharge.

The 12v system is designed to operate with a leisure battery in circuit and should not be turned on without one connected.

The 12v supply to the caravan services can be isolated via the 12v on/off switch on the control panel.



The battery must be placed in the tray provided in the battery storage compartment.

A battery of not less than 40-50 amps/hours capacity is recommended. Crocodile clips should never be used to connect the battery, and terminals should be shrouded. Always switch off all appliances and lamps before disconnecting the auxiliary battery.

- The battery should be secured to prevent movement when towing.
- Metal objects should not be stored in the battery box.
- Where a 12v extension is used between the tow-car and caravan, this should not exceed 5 metres in length- minimum cable size 2.5mm to minimise voltage drop.
- DIY modifications/additions to the wiring systems are not recommended. Always consult your retailer who will carry out such work.
- Do not continuously charge the battery when the caravan is not in use.



Negative connections should always be disconnected first and reconnected last.



Car type battery chargers are not suitable for charging a leisure battery and may damage it.



When not using the caravan always ensure that the fridge control is turned to the 'off' position. Failure to do this will result in a flat battery due to 12v power drain from the fridge circuit relays.

### BATTERY BOX CONNECTIONS

Certain models are fitted with a 12v external solar panel connection point. This can be found on the side of your van.

Certain models also feature a connection for a free standing external satellite dish. This connection is located within the external 230v socket.



Any replacement of an auxiliary battery shall be of the same type and specification as originally fitted or as specified by the manufacturer.

## CBE CONTROL PANELS

CBE control panels consist of separate switching blocks.

### 12V AND PUMP CONTROLS (SINGLE AXLES)

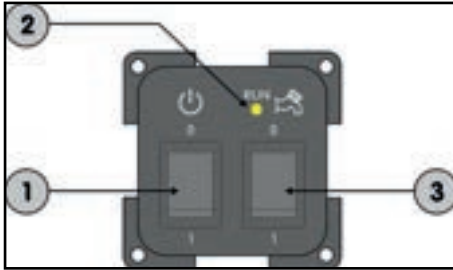

1. 12v main switch: 0 = OFF, 1 = ON.
2. LED "pump run": this LED is lit (yellow) when the pump is actually running.
3. 12V water pump switch: 0 = OFF, 1 = ON.

### 12V AND PUMP CONTROLS (TWIN AXLES)

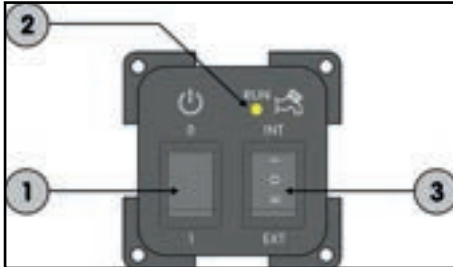

1. 12v main switch: 0 = OFF, 1 = ON
2. LED "pump run": this LED is lit (yellow) when the pump is actually running.
3. 12v water pump switch: 0 = OFF, INT= internal water pump ON; EXT= external water pump ON.

## BATTERY VOLTAGE LCD SCREEN

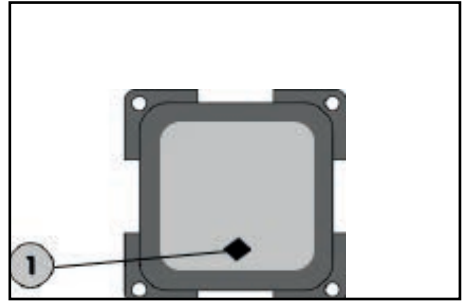

1. Button to check the voltage (in volts) of the connected 12v battery.

## VEGAS CONTROL PANELS

**1. Master Button**

When the Master Button is pressed, the control panel will switch power to all non-essential accessories.

Some features, such as lights, will need the Master Button to be switched on to work.

**2. Pump Button**

When the Pump Button is pressed, the control panel will switch power to the water pumps.

Holding down the Pump Button forces the internal pump to run regardless of tank level. This is to purge the water system.

**3. Lights Button**

When the Lights Button is pressed, the control panel will switch power to all the interior lights. The Master Button must be switched on for this button to affect the lights.

**4. Awning Light Button**

When the Awning Light Button is pressed the control panel will switch power to the exterior awning light.

The Master Button must be enabled to control the awning light.

**1. Display Indicator**

The Display indicator on the Vegas Voltmeter Panel is used to display the Leisure Battery voltage.

**2. Leisure Battery Voltage Button**

When the Leisure Battery Voltage Button is pressed, the Display Indicator will light up and display the voltage level of the Leisure Battery.

**3. Unused Button**

The right-hand button on this panel is unused, pressing this button will not cause anything to happen.

## STATUS 570/VP3 DIGITAL ANTENNA SYSTEM

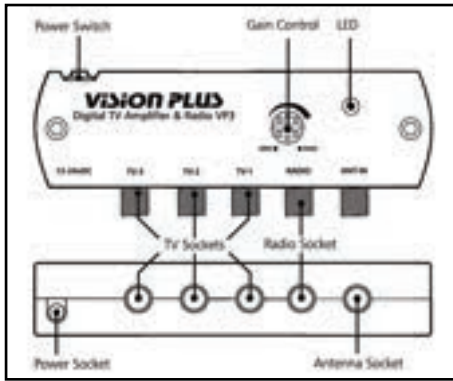

- Frequency Range UHF 470-860 Mhz
- Frequency Range VHF 40-230 Mhz
- Frequency Range FM 88-108 Mhz
- Amplifier Gain Max 18db
- Gain Adjustment 15db
- Flatness +1.5db
- Noise Figure 2db
- Output Impedance 75ohms
- Signal Handling 80dbuv
- Power Supply 10.8-28v DC
- Power Consumption 55ma

### TRAVELLING



Do not travel in the following circumstances

- With the antenna raised.
- With the antenna set for vertical signals.

When travelling adjust the antenna so that it points to the rear of the vehicle to reduce the possibility of damage when travelling.

### OPERATING

1. Firstly determine the approximate location of the nearest transmitter and whether the signals are horizontally or vertically polarised. For assistance ask your site operator or check other antennas in the vicinity.
2. Loosen the mast locking collar and raise the antenna. Rotate the mast to direct the antenna towards the TV transmitter.
3. The H/V indicator on the bottom of the

4. mast indicates the back of the antenna.
4. Should you need to receive vertically polarised signals, rotate the winder anti-clockwise to tilt the antenna through 90°.
5. DO NOT use undue force on the winder.
6. Switch ON the amplifier and the LED will illuminate.
7. Check the gain control is set to maximum. For maximum rotate clockwise.
8. Tune your television into the strongest signal. You may need to adjust the direction of the mast to achieve the best picture quality.
9. Secure by tightening the mast locking collar.

### DAB AND FM RADIO OPERATION

Status is designed to receive DAB and FM when connected to a radio with DAB/FM facility. Dependent on location, DAB and FM reception may be improved by setting the antenna to vertical. See Refer to the Radio manufactures manual for operation of radio.

### COAXIAL CONNECTIONS

It is critical that all connections in the system are fitted correctly.

### GAIN CONTROL

In normal use the button should be rotated clockwise for maximum. In strong signal areas the amplification may need to be reduced. To reduce amplification rotate the button anti-clockwise until picture quality improves. The button rotates through 270° from MAX to MIN.

### LED LIGHT

Should the LED on the amplifier not light, firstly check there is power to the unit. Secondly check the polarity is correct. Otherwise contact Grade UK Ltd for further assistance.

### SHORT HOOK UP-TEST 1

This test isolates the wiring from the amplifier through to your TV/radio points. Unplug the coaxial plugs from the "TV" sockets of the amplifier and use your TV fly lead with converter 1 supplied. Connect your TV to the amplifier.

Please ensure the antenna dome is plugged directly into the "ANT-IN" socket of the amplifier and switch on. Tune in your TV for

the strongest signal. If the picture quality improves the fault lies with the wiring of the system between the amplifier and TV outlet socket.

### **SHORT HOOK UP: TEST 2**

This test isolates the amplifier by connecting your TV direct to the antenna.

Unplug the antenna from the amplifier and connect converter 2 supplied to the plug on the cable end. Using your fly lead, connect the antenna directly to your TV. Tune in your TV for the strongest signal.

If the picture quality improves, the fault lies with the amplifier.

### **ANTENNA DOME COAXIAL CABLE**

Check the routing of the coaxial cable from the antenna dome to the amplifier. Check to ensure there are no kinks or trapped cable or if there are loops of surplus cable which could affect performance.

Should you still be experiencing difficulties and require assistance, please do not hesitate to contact Vision Plus for further assistance on +44 (0) 115 986 7151

or

Visit [www.visionplus.co.uk](http://www.visionplus.co.uk)



It is the responsibility of the caravan owner to make sure that the directional aerial is fully retracted before the caravan is moved. Any damage as a result of neglect, i.e. not retracting the aerial, crash damage, vandalism or incorrect operation will NOT be covered by the manufacturer's warranty.

### **Beginners Guide Video, Scan to view:**

Setting up your TV aerial



## SOLAR DUAL BATTERY CHARGER SDC 12

The solar module generates power when light is cast upon it. The full voltage is also available even if there is little light. The solar automatic charger only serves to charge 12v lead accumulators comprising 6 single cells (e.g. leisure battery) with a capacity of 50-110Ah. The preferred application fields for the automatic charger are batteries with gel, AGM (absorbed glass mat) or liquid electrolyte.

The device is not suitable for charging:

- 6v batteries or 6v lead accumulators
- Non-chargeable batteries
- Nickel-cadmium batteries



The device is only suitable for regulating solar modules. Do not connect any other voltage sources (e.g. main voltage 230v) to the device. This may destroy the device, sources or both. If any other voltage sources are used together with the device, please ask your retailer regarding compatibility.

### FUNCTION

The device is a MPPT, or maximum power point tracker, an electronic DC to DC converter that optimises the match between the solar panels (PV panels) and battery. This allows high performance combined with a light weight and small dimensions. By virtue of the high-quality electronics, it works highly efficiently. The automatic charging process preserves the device and does not overcharge the batteries. This in turn extends the service life of the batteries significantly. It is suitable for batteries with liquid, gel or AGM technology and has a settable charging current distribution for two separate battery connections.

The device is capable of continuous operation and parallel mode. Consumers can be continuously connected, switched on or disconnected. Consumers are supplied and the batteries are charged at the same time via the battery. The consumer current here should be smaller than the solar charging current as otherwise the battery will not charge. The supply and starter batteries can be charged by connecting one or several solar modules.

Please observe the maximum voltage and power consumption values detailed on the controller reverse. This type of connection should be completed in parallel.

### CHARGING PROCESS

The device has an electronic reverse input voltage, reverse current and solar short-circuit protection. The charging current is only released if the battery is connected correctly and there is enough power available from sunlight. When a temperature sensor is used, charging takes place on a temperature-dependent basis.

### Boost phase

Charging with maximum available solar charging current until the charging end voltage is reached.

### Float phase

The charging voltage is set to 13.8v for GEL type, see battery charging table for other types. The charging current drops to the value necessary to compensate the self-consumption of the battery. Power is still supplied to the consumers via the battery. If the consumed current exceeds the available solar charging current, the charging process can no longer be maintained. If the battery voltage drops below the selected battery type voltage, the device automatically switches to the boost phase, if there is adequate solar charging current.

### Device Elements

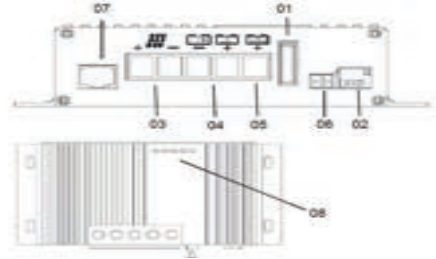

01. Main Fuse 20 amp
02. DIP switches for battery type
03. Solar input terminals - Pos/Neg
04. Main battery output terminals - Pos/Neg
05. Starter battery output terminal - Pos only
06. Temperature sensor socket (sensor optional)
07. LCD meter socket (LCD meter optional)
08. Status indication LED's



## Battery Type Selection

### Operation

On the Charge Controller bottom face, the battery type DIP switches and battery type table can be found. Confirm the type of battery being fitted and arrange the DIP switches to its corresponding configuration.

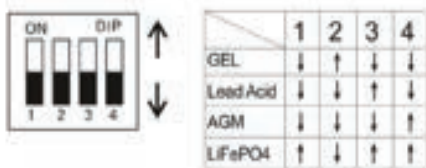

### Battery type

The battery type can only be set for Main Battery 1. Starter Battery is only supported by trickle charging to a maximum 1amp in all settings.

**ATTENTION: Only connect LiFePO4 batteries with integrated BMS!**

Note: The possible parallel/floating operation with consumers being connected to the battery is also automatically considered by all charging programs.

### Partially Discharged Batteries

(only for AGM and liquid electrolyte battery type)

In contrast to other battery types, batteries on lead basis do not have any harmful memory effect. Consequently: In case of doubt, partially discharged batteries must be charged fully as soon as possible. Always store only fully charged lead batteries. Recharge them periodically, particularly in case of used (older) batteries and higher temperatures.

- Liquid electrolyte batteries can create explosive gases, so ensure there is adequate ventilation.

Check the liquid level at regular intervals.

Overcharging can damage your battery; check the technical data for your battery. In case of insufficient solar power and/or high current consumption, the battery should be subject to occasional full charging by means of a mains supply charger.

## Overvoltage Protection

The 12v solar controllers protect themselves against connection of excessive battery voltage rates or will be switched- off in case of defective additional charging systems, switching threshold 15.0-16.0v

## Overvoltage Limit

Sensitive consumers are protected by means of a limitation of the charging voltage to maximum 14.8v during all modes of charging / battery type

## Safety instructions

This device contains parts that could cause sparks or a light arc!

Only qualified technicians may assemble and connect electrical devices!

The solar module generates power when light is cast on it. The full voltage is also available even if there is little light. The open circuit voltage may be twice as high. Do not touch any live parts. Cover solar modules with e.g. cardboard, before mounting and installing. The device was developed for the connection of solar modules.

Only use suitable modules e.g. Truma SM 25, 40, 65, 80, 100, 120, 150 or 180. Observe the maximum voltage and power draw values.

### FUNCTION DISPLAY / TROUBLESHOOTING

On the Charge Controller (CC) front face, status LED's are positioned. The following table details the indicating condition of each LED.

DISPLAY	STATUS
Batt Low - illuminated	- Main battery volatage is below 10.5 volts - Discharged battery - Insufficient battery connection - Failed supply fuse
MPP - illuminated	CC charging
MPP - short flashing	CC ready to charge
>80% - illuminated	Main battery is almost fully charged
>80% flashing 1 pulse/sec	CC overheated
>80% flashing 2 pulse/sec	Main battery or solar panel overvoltage
Batt Full - illuminated	Battery is fully charged
All LED's flashing	Battery selection is incorrect

If this does not solve the problem, please contact the Truma Service.

### REPAIRS

Do not repair or modify the solar panel. Please contact your retailer or the Truma Service.

### CAUTIONS

- Liquid electrolyte batteries can create explosive gases, so ensure there is adequate ventilation.
- Check the liquid level at regular intervals. Overcharging can damage your battery; check the technical data for your battery.
- Equalisation charging increases the charging voltage; this may damage the consumer. Ensure that all consumers are designed for these voltages.

## ALDE HEATING SYSTEM

### Introduction

The Alde Compact 3030 heating system is intended for heating recreational vehicles.

Alde Compact 3030 consists of a gas and electrical boiler and convectors. The system supplies the convectors with heat by circulating a glycol mixture, which is heated up using gas and/or electricity in the boiler.

These instructions are approved for the Alde Compact 3030 boiler fitted in caravans in accordance with CE 0402 no. SC0653-13 and have the E5 mark for installation in vehicles in accordance with ECE R122, and R10, for use in central heating and hot water systems.

The boiler is not intended for use by persons (including children) with reduced physical sensory or mental capabilities, or lack of experience and/or knowledge, unless they have been given instruction or are supervised.

The term "specified use" also covers observance of the operating and installation instructions

The Alde Compact 3030 boiler must be installed or repaired by a competent person in accordance with current local regulations. In the unlikely event that your boiler develops a fault, switch off the boiler and contact Alde, or your dealer or installer.

### Safety features

The system is fitted with the following safety devices:

#### Flame monitor

If the gas flame goes out, a flame sensor shuts off the gas supply.

#### Low current shut-off

If the current drops below 10.5 V DC, the gas supply to the burner is shut off.

#### Exhaust fan monitor

In the event of a faulty exhaust fan, the gas supply to the system is shut off.

#### Monitoring boiler temperature

A temperature switch turns the boiler off if the temperature in the boiler exceeds 90°C



### Fire/Explosion risk

- Never use LPG to run the system when filling up or when filling a fixed LPG tank.
- Never use naked flame when checking for gas leaks.
- Always use original parts from Alde
- LPG tanks must only be filled by qualified gas suppliers
- Only use LPG

### Use of the heating system

Always turn off the main switch (12 V) of the heating system when the vehicle is not in use. The LPG burner must not be running when refuelling the vehicle or when filling a solid LPG tank

### Winter and sub-zero temperatures

During winter camping, make sure that the flue and exhaust valves are kept free of ice and snow. There is a flue extension for the roof flue (Art. No. 3000 320). There is a condensation conductor for the wall flue (art. no. 3010 697). Please note that flue extensions and condensation conductors must not be used while travelling.



The fresh water in the heater should always be drained in case of frost or if the vehicle is not in use, otherwise one risks having the boiler freeze. The warranty does not cover frost damage.



For proper and safe combustion, the LPG burner in the heating system must have sufficient air intake. Insufficient air intake can cause build-up of carbon monoxide which presents an asphyxiation hazard. The induction air for the gas burner enters via the flue, which is installed on the side of the vehicle near the boiler. While winter camping, make sure that the flue is kept free of snow and ice. Do not start the heating system with LPG operation until the flue is completely free of snow and ice

## External factors that may affect the heating system

Cleaning fluids for the water system should be used with care as they may cause corrosion of the stainless steel parts of the heating system. Make sure that the detergent you are using works for stainless steel systems. Rinse the system thoroughly before using the heating system again.

Take note of hard water. Hard water is water that has high levels of minerals, chlorine, lime, and salt. If the boiler is being used in a region with hard water, install a water filter. Hard water can cause lime deposits that may cause impaired function and rust formation. When washing the vehicle, do not rinse the flue directly. This can cause poor operation as well as soot formation.



### Carbon monoxide poisoning

The heating system can generate dangerous carbon monoxide (CO) when using LPG as fuel, if not correctly installed and/or used correctly.

To avoid suffocation accidents, always use the system's LPG fuel outdoors to ensure exhaust gases are dispersed. Never use in a confined space, and never inhale exhaust gases.

Ensure that the gas exhaust is placed outdoors, and never under the vehicle's awning or under a canopy, for example.

Never use the system without adequate ventilation.

Ensure that the air inlet and exhaust outlet are not blocked.

Never allow water to enter the system when cleaning the vehicle. If using a high pressure washer for example, never spray directly into the system's exhaust outlet.

## Glycol liquid in the heating system



Never leave the heating system without glycol mixture and always maintain the correct amount of glycol mixture in the heating system.

The glycol mixture should be replaced every two years, or as recommended by manufacturers, as properties such as corrosion protection deteriorate over time. If the glycol fluid is not replaced at appropriate intervals, there is a risk of frost damage, corrosion, bacterial growth and/or overheating. If Alde Premium Antifreeze is used, the replacement period can be extended to max. 5 years of normal use.

Air pockets can form in the system; a sign of the formation of air pockets is that the pipes only heat up along the first 1-2 metres proximal to the boiler, even though the circulation pump is running.

For more information on bleeding of the heating system, see the Care and Maintenance section

## Convection

To make the most efficient use of waterborne heating, air must be able to pass freely through air gaps under the bed boxes, behind the backrests/cushions and wall cabinets. If the vehicle has fitted carpets, check that they do not prevent air supply to the convectors. It is also important that curtains, cushions, and blankets do not prevent air circulation behind backrests and wall cabinets.

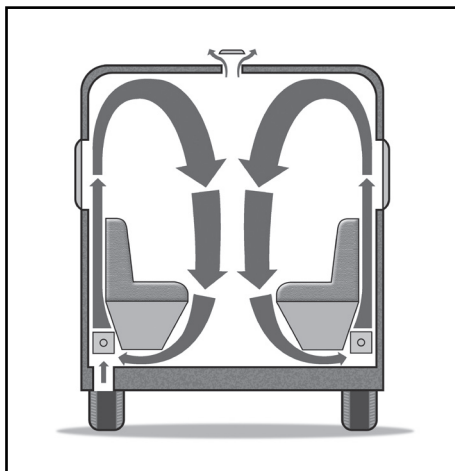

## Use of the water heater

The Alde Compact 3030 heating system has a built-in water heater. Heating of the vehicle can take place without the water heater being filled with water. The water heater can also be used without heat circulating in the vehicle; set the desired room temperature, and if you want hot water on or extra hot water, the heating system handles this function automatically.



The hot water from the boiler is not intended for drinking or cooking



Scalding hazard  
Remember: the water in the water heater may be hot

### Care and maintenance

LPG hoses should be replaced according to the date marking of the hose when they dry out and crack, resulting in possible leakage.

Turn off the main power supply (12 V) to the heating system when not in use. The main power supply shall always be switched off when the vehicle is not in use and close the tap on the LPG bottle/tank.

### Replacement of the cushion

The heating system is designed to have air space, a so-called air cushion, at the top of the hot water tank. The air cushion is absolutely necessary to enable the expansion of the water when heated, but also to absorb any pressure shocks caused by the water pump in the heating system.

Always replace the air cushion in the heating system after 10 days of use. This is done by opening the knob on the safety/drain valve to the heating system for a few seconds.

Opening the manual safety/drain valve



Fig 1

Check that the breather valve (Fig.2 [N]) is allowing air to enter the hot water cylinder when it is being drained, and that the clear plastic hose is not obstructed.

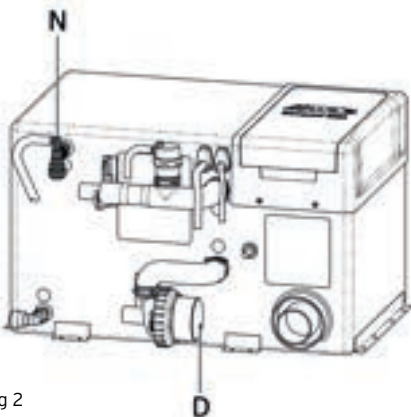

Fig 2

### Emptying of water heater and water pipes

1. Turn off the fresh water pump.
2. Open all water taps halfway, letting both hot and cold water flow.
3. Then open the safety/drain valve by bringing the yellow lever into a vertical position (Fig 1 [M]).
4. Check that all the water runs out (approx. 7-10 litres). Leave the valve open until the heater is to be used again.

### Refill the heating system with glycol fluid

Glycol content should be checked at the expansion vessel using a glycol tester before refill, to ensure that the concentration of glycol in the fluid is not too high. If the fluid level has dropped for reasons other than evaporation, check all joints, rubber hoses, drain taps and air screws for leakage before filling.

The glycol system is manually replenished in the expansion vessel (fig 3).

When manually filling, slowly pour the glycol mixture into the expansion vessel. The level must be approx. 1 cm above the MIN line when the system is cold.

Vent system after filling; add more glycol mixture if the glycol level drops during venting. Vent a newly-filled heating system regularly

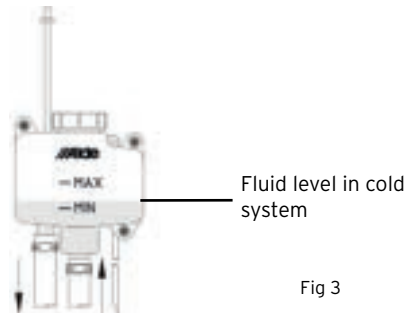

Fig 3

### Bleeding of the heating system

When adding glycol mixture to the system, air pockets may form, depending on how the piping system is installed. A sign of air in the system is that only the first few metres of the pipes extending from the boiler heat up, even though the circulation pump is running.

In the case of a newly filled heating system, small air bubbles may form in the expansion vessel resulting in rippling noise.

If the circulation pump is stopped for a few seconds, the bubbles usually disappear. If the problem persists, aerate the heating system.

### To bleed the system

- The water heater must be switched off.
- Set the temperature to 30°C and turn off electricity and gas.
- Set the 12v inline circulation pump on the side of the boiler to speed 5 (Fig.2 [D]): by turning the blue speed dial clockwise, on the face of the pump motor. NB: Speed is not adjustable if using the 12v circulation pump fitted in the expansion tank.
- After 10 mins, set the pump back to its normal running speed (2 for a caravan, 3 for a motorhome).
- Now power off the Alde Compact 3030 boiler completely, making sure that the circulation pump is not active.
- Follow the flow pipe from the boiler, and bleed the system at each bleed point. If Alde bleed points have been fitted, these are metal bleed screws mounted on black EPDM rubber connectors (Fig. 4). Have a cloth in hand. To open, turn the screw anti-clockwise between thumb and forefinger. Air will hiss out. When fluid trickles out, close the bleed screw and mop up fluid with the cloth.
- Move on to the next bleed point and repeat, until all bleed points have been attended to.
- The fluid level in the expansion tank must lie 1 cm above the min. line when the system is cold.
- Start the boiler as normal and allow to run for a while. Feel whether the pipes and convectors around the vehicle are getting warm. If they are hot, venting is complete, if not repeat procedure.



Fig 4



Be sure to thoroughly dry any puddles of leaked glycol or glycol fluid. Rinse the area with water and dry up the excess to prevent children or pets from ingesting glycol.

### Air lock

If enough trapped air accumulates at one point, an air lock can result and prevent the circulation of hydronic heating. A ramp or steep slope can be used to raise one end of the vehicle, causing the trapped air to shift around the system. Repeat the full bleed procedure. A caravan can be slowly and carefully tilted to reproduce this effect. To clear a stubborn air lock in under 15 minutes, an Alde-certified service agent can use the Alde 1900-811 or 839 twin-motor service pump.

### Operation on electricity

All Alde Compact 3030/3030PLUS heating systems are fitted with 230 V heating elements (one 1 kW and one 2 kW) with a total 3 kW output. When electric operation is selected in the Control Panel, the electrical cartridges are used to heat the heating system. The heating elements and circulation pump are controlled in a similar way to when gas operation is used.



Check that the electrical network meets the requirements before using electric power.

The power supply at different campsites varies between 6 A, 10 A and 16 A. Limit your vehicle's electric consumption to the fuse you have plugged in. 1 kW - 6 A fuse. 2 kW - 10 A fuse. 3 kW - 16 A fuse



The exhaust temperature from the LPG burner can reach 200°C. Stay away from the wall flue during LPG operation and never place flammable materials and fluids near the flue.



The Alde Compact 3030 boiler (fig 2) can get hot during operation. Do not place items on or around the Alde Compact boiler unit.

### Operation on LPG

LPG is a petroleum product officially called liquefied petroleum gas. It consists mainly of propane and butane. The advantage of propane is that it remains in gaseous form in temperatures as low as -40 °C.

Therefore, propane is used in colder climates. The LPG bottle contains LPG in liquid and gaseous form. When the bottle is filled, the gas is converted into liquid form by the pressure. When the gas cylinder valve is opened, the liquid turns to gas again

When you select LPG operation on the Control Panel, the LPG burner starts in the heating system and the pump that automatically circulates the glycol mixture every time the thermostat requires more heat

The gas burner continues to run and the pump continues to circulate the fluid until the thermostat reaches the selected temperature. If the LPG burner turns off for any reason, a sensor is activated and the heating system will automatically try to restart (after about 10 seconds).



The risk of LPG is that leaking gas can ignite, causing an explosion. Since LPG is more dense than air, leaking gas will accumulate at the lowest point in the section that contains the leak. To make it easier to detect gas leaks, a substance with a clear, strong odour has been added to the gas.



LPG contains no toxic substances, but inhalation of concentrated gas can cause asphyxiation due to lack of oxygen. Incomplete combustion of LPG can produce carbon monoxide (CO), which presents an asphyxiation hazard.

### Troubleshooting

Always start by checking any error messages. When an error occurs in the system, the cause is shown on the control panel. They are only shown when the panel's status screen is active.

#### Boiler will not start on gas (Gas Failure)



If the heating system has not been in operation for a long time, or if the gas tank has been replaced, it may take longer than normal to start the boiler.

- Run out of LPG?
- Is the main tap fully open?
- Check that the right LPG type is used for the prevalent outdoor temperature. Using butane at temperatures below +10 °C is unsuitable. Use propane instead.
- Check that the 12 V fuse for the boiler is intact.
- Check that there is a 12 V electricity supply to the boiler (> 11 V); the actual voltage can be read from the service menu.
- Check that the exhaust hose is firmly mounted between the boiler and flue, and that it is not damaged or clogged by foreign objects, condensation or water. The exhaust hose consists of two hoses, one inner and one outer.
- Check that there is nothing clogging/obstructing the passage of exhaust to the flue.
- Check that the gas pressure is correct. This can be done by lighting all the burners on the gas stove, then starting the boiler on gas. If the flames on the stove get smaller, there is a problem with the gas pressure.
- If the boiler has not been used for some time, or if the gas bottle is new, it can take a little longer to light the boiler than normal. Try restarting the boiler.
- If DuoControl/MonoControl with Crash sensor are installed, check that they have not tripped.
- If none of the above help, contact Alde Service Partner.



## Electric heater will not work satisfactorily



A 230 V power supply carries a risk of electrical accidents. Never attempt to service electrical cartridges yourself.

- Check that the fuse for the boiler is intact.
- Check that there is a 12 V electricity supply to the boiler (> 11 V); the actual voltage can be read from the service menu.
- Check that 230 V is truly being supplied to the boiler. Long and/or weak connection cables cause higher voltage drops. The voltage may also be lower under certain conditions, e.g. if the power pole at the campsite delivers less than 230 V voltage; even a slight deviation from 230 V results in high power loss of the boiler.
- Check that the selected power level on the panel is high enough, see section Energy sources.
- If fitted, check that the load monitor (option) is properly installed and set to a voltage equivalent to the electrical pole's circuit breaker.
- If none of the above help, contact Alde Service Partner.

### Poor or no heat (circulation in the system)

- Check that the circulation pump symbol is visible on the status screen when heating is needed.
- Check that the circulation pumps are working.
- Bleed the system of air.

## Service Information & Reset

Tap "Service Information" to reach the service menu on the 'Settings' screen. The values from the heating system are shown here; the values are updated continuously.

### Reset

Tap Reset on the 'Settings' screen to reset the Control Panel to factory settings. After resetting, the system will be set as follows:

- Heater - Off mode/ Boiler - Off
- Max. electricity - 1 kW/ Max. electricity - 1 kW
- Gas heating - On mode
- Target temperatures - 22.0 °C/ Temperature setting - 22.0 °C
- Hot water - In normal mode

All other functions will be switched off. The accessories/functions selected under "System configuration" are not affected by resetting.

### Further information

For more details, please refer to the 'Operating instructions Alde Compact 3030' on the Alde website [www.alde.co.uk/manuals-and-documents](http://www.alde.co.uk/manuals-and-documents)

### Warranty

Alde undertakes to rectify any manufacturing defect or early component failure through normal use that occurs within 12 months of the installation date.

If your Alde boiler develops a fault, your first action should be to contact your dealer or installer, as they will be familiar with your installation and vehicle, and how to make a claim under warranty.

Alde International (UK) Ltd  
 Huxley Close  
 Park Farm South  
 Wellingborough  
 Northamptonshire  
 NN8 6AB  
 Tel. +44 (0) 1933 677765  
[www.alde.co.uk](http://www.alde.co.uk)

## ALDE CONTROL PANEL

### QUICK START GUIDE

This quick start guide allows end users to confidently use the core features of their Alde control panel. For more details, please refer to the 'Operating instructions Alde Compact 3030' on the Alde website [www.alde.co.uk/manuals-and-documents](http://www.alde.co.uk/manuals-and-documents)

Start the system by pressing the On/Off button on the control panel. The start image is displayed and the system starts with the last selected settings. When the heating system and control panel are on, a green diode lights up on the On/Off button.

To turn off the heating system, press the on/off button. The control panel and LED switch off.

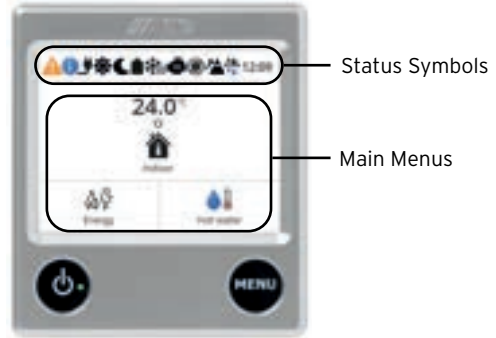

If the "Status page" is set to "Dark", the Control Panel goes dark when it enters sleep mode, but lights up when you touch the screen. Read more under Settings menu.

### Status screen

When the control panel enters sleep mode, the status screen appears. Tap the respective symbol on the status screen to reach its submenu. Press the " menu" button to reach the Settings menu and again to reach the status screen. Features marked with asterisks (\*) are accessories.

#### Symbol description of the top row of the status screen

	Operating messages. Displayed if temporary service interruption occurs; this is not an error. Await. Read more in section Operating messages.
	Information. Flashes when there is an information message.
	230 V. Electricity (230 V) is connected to the boiler.
	Day Mode. Appears when the feature is on and turns green when it is active.
	Night Mode. Appears when the feature is on and turns green when it is active.
	LPG bottle full/empty*. Appears if a DuoControl is installed. Black bottle = Gas available. Red bottle = One bottle empty.
	EisEx*. Appears if EisEx is turned on and turns green when active.
	Engine heating*. Shown if the engine heater is installed and turned on, and turns green when active.
	Anti-bacteria. The boiler's automatic bacterial elimination setting is running.
	High altitude mode. Flashes if the high altitude mode is active.
	Alde AquaClear UV-C*. Water filter.

### Main menus on the status screen

	Indoor temperature shows the current temperature and whether the circulation pump is active. Tap the icon to change the desired temperature.
	Light*. Start, turn off, or dim the AC lighting (only with Truma AC).
	Energy. Shows the energy source used; the flame turns red when gas is in use, and the flash turns yellow when electricity is in use. Tap the icon to select and prioritise energy source, and to set load monitor* and high altitude mode.
	Hot water. Indicates whether hot water production is on, "boost" or turned off. Press the respective controls to start/switch off or increase hot water production. The thermometer fills up entirely when the hot water reaches boost temperature.
	Outdoor temperature*. If an outdoor sensor is installed, the current outdoor temperature is displayed.

### Set the desired temperature

The temperature can be set from +5°C to 30°C in increments of 0.5°C. To set the temperature, press "Indoor". The temperature shown reflects the temperature currently set.

- To raise the temperature, press the plus button to the right of the temperature.
- Lower the temperature by pressing the minus button, to the left of the temperature.

You can leave the menu by clicking the Back arrow in the upper left part, or by pressing the "menu" button once; the heating system works directly to reach the set temperature.



Set temperature



Scalding hazard When the hot water and glycol mixture in the boiler are heated at the same time, the hot water can become very hot in the event of a significant heating requirement.

### Hot water

In the boiler there is a built-in water heater with a capacity of about 8.5 litres. The boiler can be used even without fresh water being in the heater. There are three different settings for hot water: no hot water, normal operation and boost (prioritised hot water).

- No hot water or normal operation. Press the on/off button on the screen under hot water to switch between no hot water production and normal hot water production.
- "Boost", (prioritised hot water production). Tap the slider to the right of the text that reads "Boost 30 minutes". The boiler will now prioritise the production of hot water for 30 minutes. After 30 minutes have passed, the boiler returns to its previous setting. Prioritised hot water production is recommended for increased hot water demand.



Set up hot water production

## Energy sources

The boiler can be powered either by gas or electricity, or both at the same time. The fastest heating is obtained by using both energy sources at the same time, as the overall power available will be greater. Hence, more power, equals faster heating. It is also possible to prioritise which energy source to use, when both gas and electricity are switched on; in the event of high heat demand, both are activated. When the boiler approaches the set temperature, energy consumption is gradually reduced.

## Heating with Electricity

The consumption selected in the menu is the maximum consumption permitted, i.e. the boiler does not use more power than is required, even if e.g. 3 kW is selected in the Control Panel.

Tap the "Energy" menu bar to open the electric power settings menu.

Increase or decrease the maximum permissible electrical power between 0-3 kW using the plus and minus buttons. 0 kW equals electric operation being switched off.

Confirm your selection by pressing the "Set" button. Press "Cancel" to cancel.

## Heating with gas

Tap the slider on the "Gas" menu bar to start and shut off gas operation.

## High Altitude mode

High altitude mode is only to be used if the boiler will be powered by LPG at altitudes exceeding 1000 m above sea level. For high-altitude LPG operation, use propane to ensure stable combustion. Varied operating conditions at high altitudes may cause the boiler to not always reach full gas operation.

Tap the slider on the "High altitude mood" menu bar to start and turn off throttle.

This feature is reached by accessing the second page (tap the top right corner). To return tap the arrow on the top left corner

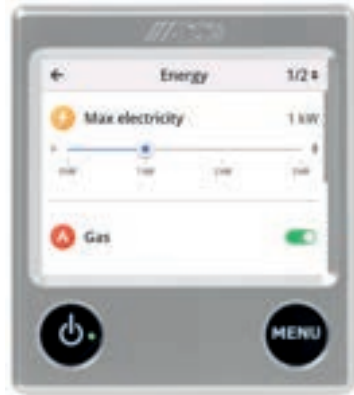

Choice of energy modes

## Settings Menu

To reach the Settings menu from sleep/standby screen, press the "menu" button. Features marked with asterisks (\*) are accessories. The Settings menu provides the following features:

	<p>Night Mode. Automatically changes select features during the night. Choose the time interval and whether it should be done every night or a specific night each week. The following can be changed: temperature, status screen light, putting AC* into night operation and changing AC sensors, turning off hot water production, and underfloor heating*.</p>
	<p>Day Mode. Automatically changes select features throughout the day. Choose the time interval and whether it should be done every night or a specific night each week. The following can be changed: temperature and hot water production.</p>
	<p>AC* (Truma only). Start or turn off automatic climate setting (=AC and the heating system work together); for dual-zone installation, choose which zone the AC should follow.</p>
	<p>EisEx, defroster for gas regulator. Prevents ice formation in the regulator during winter. Select on or off, and select whether EisEx should automatically turn on when it is cold. Automatic switch-on requires an outdoor sensor to be installed.</p>
	<p>Delayed start, automatic boiler start. Start or turn off the feature, select start and end time. For the function to work, the boiler must be switched off.</p>
	<p>External start. The function is used when starting the boiler from outside. When external startup is enabled, the panel should be turned off. External start has three modes: Off, External start and 230 V. Off. The function is turned off. External start*. The function is used when starting the boiler with external start, by switching the "Ext Start" connector on the boiler's circuit board. When the External Start function is activated, the control panel should be turned off but 12 V is connected. 230 V. The function is used to start the boiler by connecting 230 V to the vehicle. When the 230 V function is activated, the control panel should be switched off but 12 V connected. Some vehicles may be equipped with their own solution (winter coupling*).</p>
	<p>Temp sensor calib., offset for temperature sensor. If you feel that the temperature sensor should be slightly adjusted, the temperature can be adjusted by +/- 5 °C. Also applies to outdoor temperature sensor.</p>
	<p>Display. Select panel brightness: Low, Medium, or High. You can also choose whether the status screen should be Normal, Inverted, or Dark. If Dark is selected, the panel will go dark after 30 seconds and will light up again if touched.</p>
	<p>Sound. Start or turn off button and warning/notification sounds.</p>
	<p>Language. Change the language in the Control Panel menus; available languages are: English, German, and French.</p>
	<p>Service. Displays values from the heating system; these are updated continuously and describe the current status of the boiler.</p>
	<p>System configuration, enable installed accessories and features. Here, you will find all accessories or functions that can be connected to the Alde Heating System; tick the features that are installed in the heating system to enable their use.</p>
	<p>Reset. Resets the panel to factory setting. The accessories/features selected under System Configuration are not affected</p>

## Error Messages

When an error message appears on the Control panel, the LED on the On/Off button changes to red.

**Connector failure:** Check the red cable between the boiler and the panel and its red connectors. Also check cables connected to the black connector of the boiler, e.g. cable between AC or iNet box and boiler or panel.

**Heater not found:** There is a connection fault between the boiler and the control panel. Most likely a problem with the boiler circuit board; contact your dealer. The fault may also be due to incompatible software in the boiler and panel.

**Overheat glycol:** This fault can occur if the boiler is running at high power while there are air pockets in the system; ventilate the heating system properly. Also check that the liquid level in the expansion vessel is at least 1 cm above the MIN mark when the liquid is cold. It can also occur if the circulation pump has broken or is disconnected from the boiler. To restore the fault, the glycol temperature must drop to below 50°C. Once this happens, remove, then reconnect 12 V to the boiler.

**Overheat lockout:** There has been an episode of overheating in the boiler. The temperature has gone down but the boiler is still locked. To reset the fault, disconnect, then reconnect, 12 V to the boiler.

**Overheat PCB:** Overheating in the boiler or boiler compartment. To reset the error, the temperature in the pan must first drop. Disconnect, then reconnect 12 V to the boiler. If this does not help, contact Alde Service Partner.

**Heater failure:** The circuit board is damaged. To reset the fault, disconnect, then reconnect 12 V to the boiler. If the error persists, contact Alde Service Partner.

**Low battery voltage:** If the vehicle's battery voltage to the boiler is less than 10.8 V, the boiler stops. This resets automatically when the voltage reaches 11 V. If the voltage is lower, other error messages may also appear. These error messages occur only because the battery voltage is/has been too low and are therefore not true malfunctions. Ensure that the boiler

gets the right voltage for the right function.

**Gas failure:** Ensure that gas is available to the boiler. To reset the fault, disconnect and reconnect 12 V to the boiler; after reconnecting 12 V, gas operation must be reactivated in the control panel. The fault may also be due to a defective spark generator and/or burner; contact Alde Service Partner if the fault persists.

**Fan failure:** The combustion fan is defective. Contact Alde Service Partner.

**Window open:** A window switch indicates that a window near the wall flue is open, the boiler stops running on gas. Gas operation restarts when the window is closed. Electric operation still works.

**Panel failure:** May occur if the panel has been exposed to high humidity for a long time. Make sure the panel is dried, then restart. If the error persists, contact Alde Service Partner.

**Opt. dongle not found:** A previously identified option card is missing from the boiler. Make sure it is connected or uninstall the accessories that require it. In order for the system to find the option card again, disconnect 12 V from the boiler, plug in the option card, and then reconnect 12 V. If the error persists, contact Alde Service Partner.

**Load monitor not found:** A previously identified load monitor is missing from the boiler. It is either disconnected or defective. Make sure that the load monitor is plugged in; if the fault persists even though the load monitor is plugged in, contact Alde Service Partner.

### Zone 1 sensor error/ Zone 2 sensor error:

The room sensor in zone 1 or zone 2, e.g. by sofa or bed, is disconnected or defective. Check that the sensor is plugged in and that neither the sensor nor the cable is defective. If the error persists, contact Alde Service Partner.

**Hot water sensor error:** The hot water sensor is disconnected or defective. If the error persists, contact Alde Service Partner. The boiler continues to work but does not actively produce hot water; however, the water can still get hot if the boiler produces heat.

**Outdoor sensor error:** The outdoor temperature sensor is disconnected or defective. If it has been disconnected, please press the “dismiss” button in the control panel.  
**CI-bus error:** High communication load on the yellow connector of the control panel. Check the cable, couplings, and your vehicle’s master panel. If the error persists, contact Alde Service Partner.

**iNet Connection error:** the iNet box is disconnected or defective. If it has been disconnected, please press the “dismiss” button in the control panel.

**Remote Control error:** Remote control connected to the JP3 connector on the back of the Control Panel is disconnected or defective. Check cable and couplings. If it has been disconnected, press the “uninstall” button on the control panel.

**Alde Voice not found:** The main unit of Alde Voice Control is disconnected or defective. If it has been disconnected, please press the “dismiss” button in the control panel.

### Operating messages

An operating message is not a fault but a temporary service interruption. If an error occurs, an error message will appear on the screen.

#### Fan restarts...:

The combustion fan did not reach sufficient speed. A new start attempt will be made within a few minutes. This is not a fault. If “Fan failure” appears after several “Fan restarts...”, then a fault has occurred. Please wait for as long as “Fan restarts...” appears.

#### Full gas power unavailable:

The combustion fan did not reach sufficient speed for full gas operation. This can occur if “High Altitude Mode” is turned on; read more about this feature in section Energy sources.

If the message arrives without High Altitude Mode being turned on and the error persists, contact Alde Service Partner.

### BATTERY BACK UP

Certain Bailey models feature battery back up. This feature means that when all power to the caravan is cut or fails the Alde control panel will maintain its memory and settings.



The back up hardware comprises of a lead and a battery holder which accepts x2 AA batteries.

Upon receipt of your caravan you will need to insert x2 AA batteries.

**Beginners Guide Video,  
 Scan to view:**  
 Setting up your Alde heating system



## HEATING SYSTEMS

### TRUMA COMBI E

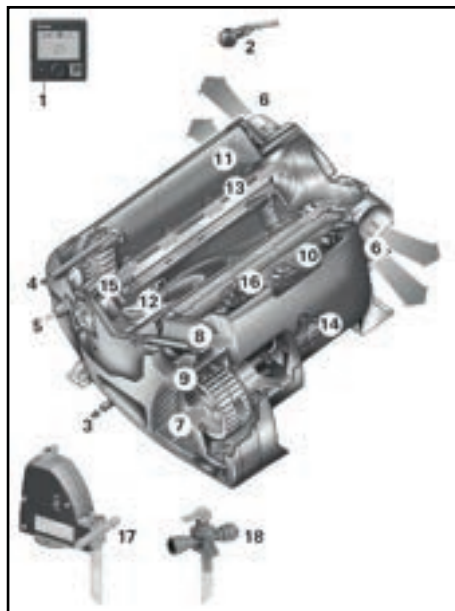

1. Control Panel
2. Room Temperature Sensor
3. Cold Water Connection
4. Hot Water Connection
5. Gas Connection
6. Hot Air Outlets
7. Recirculated Air Intake
8. Waste Gas Discharge
9. Combustion Air feed
10. Electronic Control Unit
11. Water Container (10 litres)
12. Burner
13. Heat Exchanger
14. Power Electronics
15. Heating Elements 230V
16. Overheating Switch 230c
17. Frost control (Optional)
18. Safety Drain Valve

### FUNCTION DESCRIPTION

The liquid gas heater Combi E is a warm-air heater with integrated hot water boiler (10 litres volume). The burner is fan assisted, which ensures that operation is problem-free, even when on the move. The unit also has heating elements for electrical operation. In heating and hot water mode the heater can be used to heat the room and heat water up at the same time. If only hot water is required, select hot water mode.

3 different options are available for operating the unit:

- Gas mode only Propane / Butane
- Electrical mode only 230 V for stationary use on camp sites
- Gas and Electrical mode - mixed mode only possible in winter.



Mixed operation is not possible. With this setting the unit automatically selects electrical operation. The gas burner is not enabled.



Repairs may only be carried out by an expert.

### HEATING AND HOT WATER MODE

In heating and hot water mode, the unit automatically selects the required operating level according to the temperature difference between the temperature set on the control panel and the current room temperature. If the boiler has been filled, the water is automatically heated as well. The water temperature depends on the selected operating mode and the heater output.

All 3 energy selection options can be used for winter deployment.

- In gas mode the unit automatically selects the operating level that is required.
- In electrical mode output of 900 W (3.9 A) or 1800 W (7.8 A) can be manually preselected in accordance with the fuse protection at the camp site.

If more output is required (e.g. heating up or low outside temperatures) gas or mixed mode should be selected so that enough heating power is always available.

- In mixed mode 230 V electrical mode is preferred if the power requirement



is low (e.g. for maintaining the room temperature). The gas burner is not enabled until the power requirement is higher, and is the first to switch off during heat-up operations.

#### HOT WATER MODE (WITH FILLED BOILER ONLY)

Gas mode or 230 V electrical mode is used to generate hot water. The water temperature can be set to 40 °C or 60 °C.

- In gas mode the water is heated at the lowest burner setting. Once the water temperature has been reached, the burner switches off.
- In electrical mode output of 900 W (3.9 A) or 1800 W (7.8 A) can be manually selected in accordance with the fuse protection at the camp site. Mixed mode is not possible. With this setting the unit automatically selects electrical mode. The gas burner is not enabled.

#### OPERATING INSTRUCTIONS

Read the safety instructions and operating instructions carefully before starting the unit.

The installer or vehicle owner must apply the yellow sticker with warning information, which is enclosed with the appliance, to a place in the vehicle where it is clearly visible to all users (e.g. on the wardrobe door) Ask Truma to send you stickers if necessary.

Before using for the first time it is essential to flush the entire water supply system through with clean water.

If the heater is not being used, always drain the water contents if there is a risk of frost. There shall be no claims under guarantee for damage caused by frost.

Materials in the device which come into contact with water are suitable for use with drinking water (see manufacturer declaration: [www.truma.com](http://www.truma.com) - Manufacturer Declaration).

#### ROOM THERMOSTAT

To measure the room temperature, an external room temperature sensor (s) is located within the vehicle by the control panel.

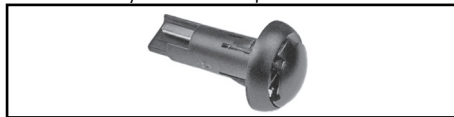

The thermostat setting on the control panel (1-5) must be determined individually depending on the heating requirement and the type of vehicle. For an average room temperature of about 23 degrees we recommend a thermostat setting of about 4.

#### FILLING THE WATER HEATER

- Check the safety/drain valve within the cold water intake is closed. The lever should be in horizontal position e.

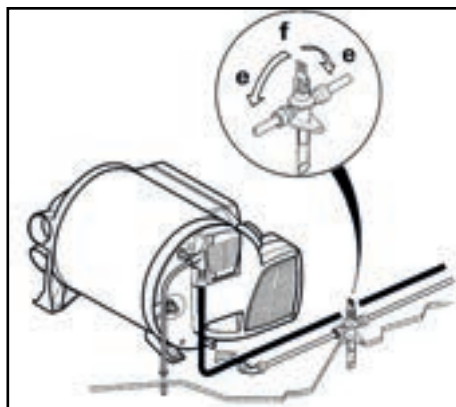

e. Lever position "closed"

f. Lever position "drain"

- Open the hot tap in the bathroom or kitchen, with pre-selecting mixing taps or single-lever fittings set to "hot".
- Switch on power for water pump (main switch or pump switch).
- Leave tap open to let air escape while the water heater is filling. The heater is filled when water flows out of the tap.

Residue of frozen water can prevent filling if there is a frost. The water heater can be defrosted by switching on the heater for a short period. Frozen pipes can be defrosted by heating the room.

## DRAINING THE WATER HEATER



If the caravan is not used during the winter the boiler must be drained prior to storage

- Disconnect power for water pump.
- Open hot the water tap in the bathroom and kitchen.
- Open safety/drain valve: Move the lever to vertical position f.

The water heater is now drained directly to the outside via the safety/drain valve. Check that the water contents have been completely drained (10 litres).

If just the cold water system is being operated without using the water heater, the heater tank also fills up with water. To avoid frost damage the boiler must be drained through the drain valve even if it was not operated.

When connecting to a central water supply (rural or city mains) a pressure reduction valve must always be installed to prevent above 2.8 bar from developing in the water heater.

There shall be no claims under guarantee for damage caused by frost.

## START UP

Heating is possible with gas, electrical and mixed operation. Also with or without water.



Check to make sure the flue is unobstructed. Be sure to remove any covers that may be present.

- Turn on gas cylinder and open isolating tap in the gas supply line.
- Check whether the power supply fuse protection on the camp site is adequate for the 900W (3.9A) or 1800W (7.8A) that has been selected using the power selector switch.
- Fill boiler with water if necessary.
- Switch on the unit on the control panel.

## SWITCHING OFF

- Switch the heater off on the control panel.
- The switch-off procedure may be delayed by several minutes because of internal heater operations



Always drain water contents if there is a risk of frost

If the appliance is not used for a long period, close the quick acting valve in the gas supply line and the gas cylinder.

## MAINTENANCE

Only original Truma parts may be used for maintenance and repair work.

- Clean the compartment where the unit is installed at least once annually.
- Have an expert check the unit for dirt and clean it if necessary.
- The safety/drain valve must be operated regularly (at least twice annually) to remove limescale deposits and to be certain that it is not blocked.

We recommend the use of suitable commercially available products to clean, sterilise and maintain the boiler. Products containing chlorine are not suitable.

The effectiveness of the use of chemicals to combat micro-organisms in the appliance can be increased by heating the water in the boiler to 70 °C at regular intervals.

- Select "Gas mode".
- Set the water temperature to 60 °C.
- Switch on the appliance.



Once the water in the boiler has reached a temperature of 60 °C, the burner will switch off. The appliance must stay switched on for at least 30 minutes and no hot water may be removed. The residual heat in the heat exchanger will heat the water up to 70 °C.

**12v FUSE REPLACEMENT**

The fuse is in the electronics beneath the connection cover.

Replace the unit's fuse only with an identical fuse.

Device fuse 10 A - low - (T 10 A)

**230v FUSE REPLACEMENT**

The fuse and the power supply lines must only be replaced by an expert.

The unit must be disconnected from the mains before opening the electronic housing lid.

The fuse is in the power electronics beneath the electronic housing lid.

This fine fuse must always be replaced with a fuse of the same type: T 10 A slow, interrupting capacity H.

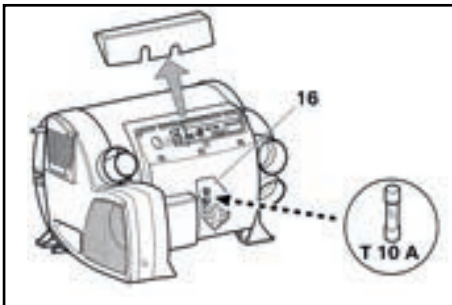
**OVERHEATING PROTECTION 230v**

The 230v heating facility has a mechanical overheating switch. If the 12v power supply is interrupted during operation or during the after-run period for example, the temperature within the unit could activate the overheating protection.

To reset the overheating protection, allow heater to cool, remove connection cover and press red reset button.

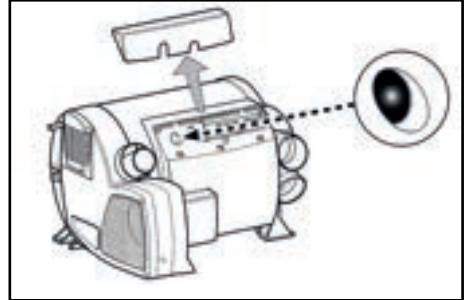

## TRUMA DIGITAL CONTROL PANEL

### SAFETY INSTRUCTIONS

- The device may only be operated if it is in perfect working order.
- Arrange for malfunctions to be rectified immediately.
- Do not repair or modify the device.
- Only allow the manufacturer or its customer service to repair a faulty device.



If the power supply to the system is interrupted for longer than 20 minutes, the time and date need to be entered again.

If the Truma Combi heater is connected to the control panel Truma CP Plus, the heater can no longer be switched via a ZUCB timer.

### DISPLAY AND CONTROL ELEMENTS



1. Display
2. Status bar
3. Menu line (Upper)
4. Menu line (Lower)
5. Display of mains voltage 230v (Power)
6. Time switch display
7. Settings/values
8. Rotary push button
9. Back button

The menus can be selected in lines (3 + 4) and settings can be made using the rotary push button (8). The display (1) has an illuminated background. The Back button (9) can be used to return from a menu.

### ROTARY PUSH BUTTON

Set points and parameters can be selected, modified and saved by tapping on it using the rotary push button (8). Selected menu items flash.



Turn to the right (+)  
Menu is paged from left to right. Increase values.  
Turn to the left (-)  
Menu is paged from right to left. Reduce values.



Clicking Accept (save) a selected value.  
Select a menu item or a change to the setting level.



Press (3 seconds) Main switch function ON/OFF

### BACK BUTTON

Pressing the Back button (9) returns you from a menu and discards settings. This means that the previous values are retained.

### SHUT DOWN PROCEDURE

Truma heating systems now require a correct procedure be followed when shutting down.

1. Press and hold the rotary push button for 3 seconds. The control panel will power down.
2. Power down the van at the master switch control panel.

This process must be followed. Failure to do so will lead error code E-514-H.

In the event of E-514-H being displayed keep the power on and wait till the code stops flashing (Approx. 15 minutes). Then press the rotary button twice to continue as normal.

## START UP

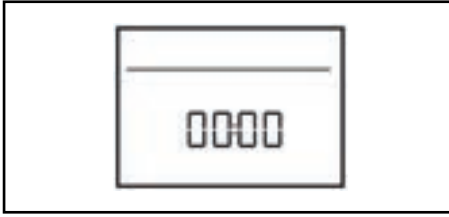

Once connected to the power supply the control panel will display a start screen. This is shown after a few seconds.

If no entry is made within a few minutes, the standby screen is automatically shown again. The display shows the time and correct room temperature alternately.

## FUNCTIONS



The functions in the menu lines of the control panel can be selected in any sequence. The operating parameters are shown in the status line at the top of the screen above the black line.

The display shows the setting level. The first symbol flashes.



Previously set values/operating parameters become active again after the system is switched on.

Switch on/return to setting level

- Press the control knob/push button for longer than 3 seconds or the back button.

Switch off

- Press the control knob/push button for longer than 3 seconds.

## CHANGE THE ROOM TEMPERATURE

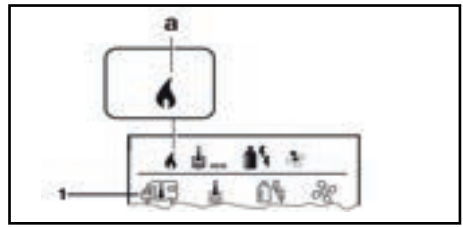

1. Use the control knob/push button to select the vehicle icon.
2. Push knob/push button to access setting level.
3. Use the control knob/push button to select the desired temperature.
4. Click the control knob/push button to confirm the value.

Temperature range 5°C-30°C (1°C steps)

a = Heater status - When visible heater is switched on.

This symbol will flash until the required room temperature is reached.

## CHANGE THE HOT WATER LEVEL

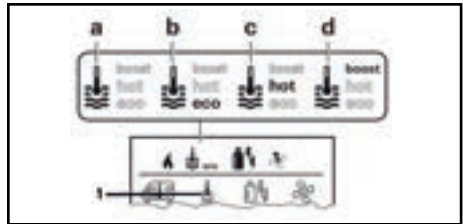

1. Use the control knob/push button to select thermometer icon.
2. Click to change to the setting level.
3. Use the control knob/push button to select the required level.
4. Click the control knob/push button to confirm the value.

a = Boiler - Warm water boiler is switched on.

b = 40° - Warm water temperature 40°C.

c = 60°C - Warm water temperature 60°C.

d = Boost - Targeted, fast heating of the content of the boiler. The water temperature is kept at the higher level (around 62°C).

Once the water temperature is reached, the room is heated again.

### SELECT ENERGY SOURCE

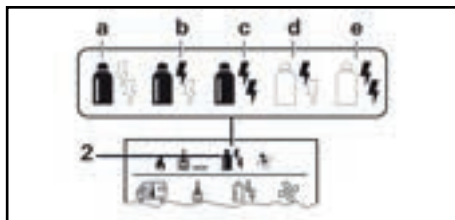

1. Use the control knob/push button to select the energy icon.
2. Click to change to the setting level.
3. Use the control knob/push button to select the required power type.
4. Click the control knob/push button to confirm the value.

SYMBOL	OPERATING MODE	POWER TYPE
a	LP gas LP gas	
b	MIX 1 * Electricity	850W + Gas
c	MIX 2 * Electricity	1700W+ Gas
d	EL 1 * Electricity	850W
e	EL 2 * Electricity	1700W

\* Mixed mode

### SPECIAL ASPECTS IN THE MIXED MODE

Interruption of the power supply 230v

**Combi Gas:** The heater automatically switches to the gas mode. As soon as the 230v power supply is connected, the heater automatically switches back to the mixed mode.

### MALFUNCTION IN THE COMBUSTION PROCESS (E.G. LACK OF FUEL)

**Combi Gas:** The heater automatically switches to the electro mode. If the heater should operate in the mixed mode again, the cause of the malfunction needs to be rectified. Switch the heater off and on again on the control panel.

### SELECT FAN LEVEL

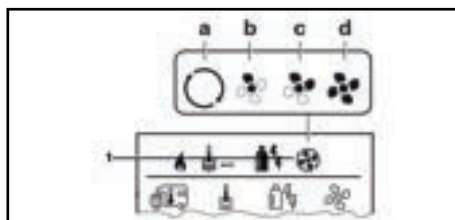

1. Use the control knob/push button to select the fan icon.
2. Click to change to the setting level.
3. Use the control knob/push button to select the required fan level.
4. Click the control knob/push button to confirm the value.

### SET THE TIME SWITCH

1. Use the control knob/push button to select the timer symbol in the bottom corner.
2. Click to change to the setting level.

If the timer is activated (ON), the timer in the menu is shown as deactivated (OFF).

Enter start time

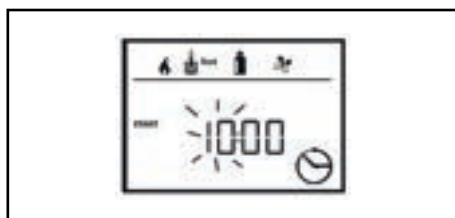

3. Use the control knob/push button to set the hours, then the minutes.

Enter end time point



4. Use the control knob/push button to set the hours, then the minutes.
5. If the start time has passed when entered the operating parameters are only taken into consideration when the next start/end times

are reached.

**Set the Room Temperature**



6. Click to change to the setting level.
7. Use the control knob/push button to select the required room temperature.
8. Click the control knob/push button to confirm the value.

**Set the Hot Water Level**

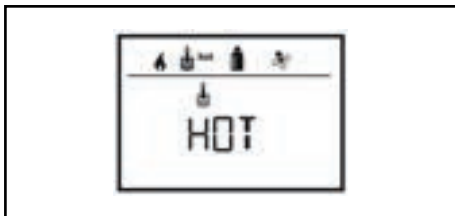

9. Click to change to the setting level.
10. Use the control knob/push button to select the required hot water level.
11. Click the control knob/push button to confirm the value.

**Select Power Type**

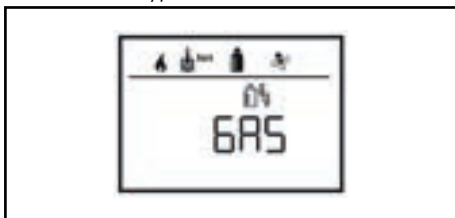

12. Click to change to the setting level.
13. Use the control knob/push button to select the power type.
14. Click the control knob/push button to confirm the value.

**Select Fan Level**



15. Click to change to the setting level.
16. Use the control knob/push button to select the required fan level.
17. Click the control knob/push button to confirm the value.

**ACTIVATE THE TIMER (ON)**

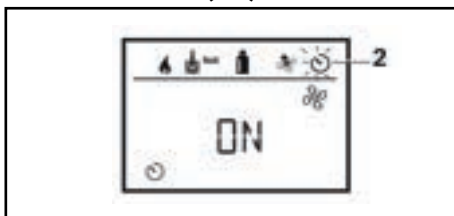

18. Click to change to the setting level.
19. Use the control knob/push button to activate the timer (ON).
20. Click the control knob/push button to confirm the value.



The timer remains active, even for several days, until it is deactivated (OFF).

**DEACTIVATE THE TIMER (OFF)**

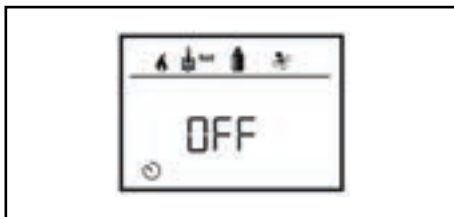

1. Click to change to the setting level.
2. Use the control knob/push button to deactivate the timer (OFF).
3. Click the control knob/push button to confirm the value.

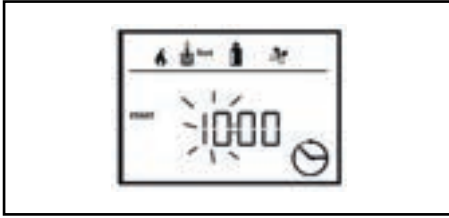
**SET TIME**

1. Select the clock icon.
2. The hour display flashes.
3. Use the control knob/push button to set the hour (24h mode).
4. After clicking the control knob/push button again, the minute display will flash.
5. Use the control knob/push button to set the minutes.
6. Click the control knob/push button to confirm the value.

**DISPLAY MAINS VOLTAGE 230v**

This symbol indicates that 230v mains voltage is available.

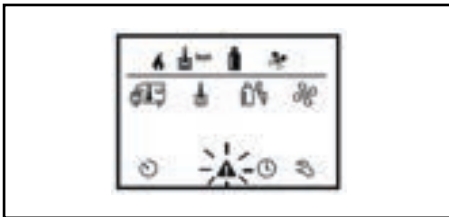
**WARNINGS**

In the event of a warning, a warning symbol appears to indicate that an operating parameter has reached an undefined status. In this case, the affected device continues to run. As soon as the operating parameter returns to set range, this symbol will turn off automatically.

**READ OUT OF WARNING**

W = Warning  
42 = Fault code  
H = Device (H=Heater)

1. Use the control knob/push button to select the symbol.
2. Click the control knob/push button. The current warning code is shown. The cause of the warning can be identified and rectified via the error list.

**CAUSE RECTIFIED/RETURN TO SETTING LEVEL**

- Click the control knob/push button.

**CAUSE NOT RECTIFIED/RETURN TO SETTING LEVEL**

- Press the back button.



In this case, the warning is not acknowledged on the control panel and the warning symbol remains. The control panel remains in the warning status. Devices connected to the control panel can be operated.

**CANCELLING THE WARNING TRIANGLE**

When the warning triangle is illuminated it indicates a fault. In order to remove the fault triangle you must first resolve the issue. Once the issue has been resolved rotate the knob until the warning triangle flashes. Depress the knob and the flashing will stop.



If the fault has not been resolved the warning triangle will reappear. Continuous cancelling of the warning triangle when the fault has not been resolved will lock the system. Stopping any further function for up to 15 minutes.

**Beginners Guide Video,  
Scan to view:**  
Setting up your Truma heating system





## EXTERIOR FEATURES

### GRP

GRP components need to be washed, waxed and cared for like a car. Chemicals and dirt can collect during storage, and the outer surface called a gel coat can be stained or marked when chemicals combine with rain or dew. Most stains or marks can be removed with mild dish-washing detergent, but more stubborn marks may require a rubbing compound. To help keep your GRP components looking almost like new, it is wise to wash the parts monthly (or more frequently) using mild dish-washing detergent, but avoid using strong alkaline (e.g. tri-sodium phosphate) or acidic cleaners or abrasives. Waxing the components once or twice a year with a good grade paste wax will help to maintain the colour and finish.

## ROOFLIGHTS

### HEKI ROOFLIGHTS:

#### OPENING IN THE TILT SETTING

1. Press the locking buttons at both catches on the glass and turn inwards through approx. 90°.
2. Grasp the bar in the middle, unclasp from the anchoring fasteners, swivel the bar down and push the glass dome upwards. (Glass dome is assisted after approx. 150mm by the two pneumatic springs.)
3. Swivel the bar towards the glass dome and clip into position.
4. To close the HEKI, perform steps (1-3) in reverse order.

#### OPENING IN THE INTERMEDIATE SETTING

1. Open both catches on the glass.
2. Grasp the bar in the middle, unclasp from the anchoring fasteners, swivel down and push the glass dome upwards. (Glass dome opens automatically after approx. 150mm through the two pneumatic springs.)
3. Open both fasteners, and swivel the bar towards the intermediate setting and pull the glass dome down until the bar rests in the hold.
4. Secure the bar with the two fasteners.
5. To close HEKI, perform steps (1-4) in reverse order.

#### OPENING IN PERMANENT VENTILATION SETTING

1. Open both catches on the glass.
2. Push glass dome up approx. 2cm with both hands on the two catches and turn the catches to fix them in the ventilation setting.
3. To close HEKI, perform steps (a-b) in reverse order.

#### CLOSING THE BLIND

1. To close the blind, grasp the end rod (without grip) in the recess and engage in the opposite end rod (with grip).
2. You can move both joined end rods to adjust the blind to the required position (black out/fly screen/sun shade).

### OPENING THE BLIND

1. Move the blind right out to the side (end rod with grip).
2. Holding the recess with one hand, press the rocker with the other hand and guide the blind back into position.

### SAFETY INSTRUCTIONS

- Do not stand on the acrylic glass.
- Close HEKI completely before moving the vehicle.
- Close HEKI when leaving the vehicle.
- Please consult your dealer when any defects or problems occur.
- Remove snow/ice or other dirt from the roof before opening HEKI.
- Do not open in strong winds or heavy rain.

### CARE INSTRUCTIONS

- Please clean the acrylic panes with the Seitz Acrylic Cleaner.
- Stains and light scratches on the acrylic pane can be removed using the Seitz Acrylic Polish and Seitz special polishing cloth.
- Only use water and mild soap suds to clean the blinds.
- Failure to comply with these instructions will make the warranty null and void.

### MPK ROOFLIGHT

The MPK rooflight is situated in the bathroom of your caravan over the shower compartment. It is fitted with a fly screen for your comfort. The fly screen is hinged, allowing you access to the handles that enable you to raise the rooflight's dome for ventilation.

To raise the dome pinch the black parts of the handle against the other half on both sides and push upwards. Both sides can be raised or just one, depending on your preference.

## COOKING EQUIPMENT



Never use oversized pans as this will lead to damage within the caravan.

- Each burner will support pans from Ø10 to Ø18cm; care should be taken not to overload the appliance as performance may be reduced.
- The following pan sizes are the maximum we recommend:
- Electric hotplate: - Ø180mm (Dual Fuel only)
- Auxiliary burner: Ø180mm
- Semi-rapid burner: 2x Ø180mm or 1x Ø180mm with 1x Ø180mm
- When using small pans the flames should not spread beyond the base of the pan as this will reduce the efficiency of the burner.
- Avoid old or misshapen pans as these may cause instability.
- The lid must be opened fully prior to using the hotplate burners.
- For guaranteed damage free cooking it is recommended you use Ø180mm pans.

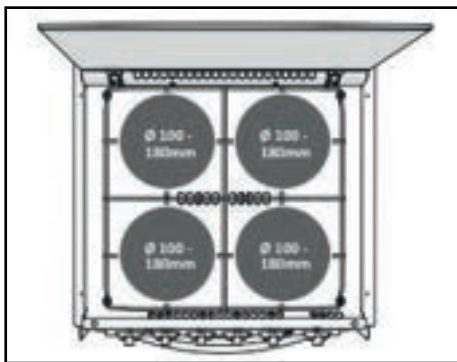

Never use the cooker as a space heater

Before using the appliance please ensure that you are aware of the following:

- Appliance and accessible parts become hot during use.
- Avoid touching heating elements.
- Children less than 8 years of age shall be kept away unless continuously supervised.

This appliance can be used by children aged 8 years and above, persons with reduced physical, sensory or mental capabilities and/or lack of experience and knowledge only if they

have been given supervision or instruction concerning use of the appliance in a safe way and understand the hazards involved.

- Children shall not play with the appliance.
- Cleaning and user maintenance shall not be made by children without supervision.
- Unattended cooking on a hob with fat or oil can be dangerous and may result in fire.
- Never extinguish a fire with water; switch off the appliance and cover flame with lid or fire blanket.
- Danger of fire: Do not store items on the cooking surface.
- Do not use harsh abrasive cleaners or sharp metal scrapers to clean the oven door glass since they can scratch the surface, which may result in shattering of the glass.
- Never use a steam cleaner to clean the appliance.

### OPERATION

The burners on this appliance have fixed aeration and no adjustment is required. The burners should flame as follows:

Propane: The flames should burn quietly with a blue/green colour with no sign of yellow tips.

Butane: Normally, on initial lighting, a small amount of yellow tipping will occur. This then increases slightly as the burner heats up.

### USING THE HOTPLATE GAS BURNERS



Ensure that the glass lid is open before turning on the burners.

- Glass lids may shatter when heated.
- Turn off all burners before shutting the lid.
- The glass lid has a tendency to snap shut towards the lowered position. Ensure fingers are away from the entrapment area when closing the lid.
- Remove all spillages from the glass lid before opening.
- Children should be supervised to ensure that they do not play with the appliance.
- Ensure gas cylinder/supply is connected and turned on. In the event of a gas smell turn off at gas cylinder/mains and contact supplier.
- Flame supervision: each burner is controlled individually and is monitored by a thermocouple probe. In the event of the burner flames being accidentally extinguished, turn off the burner control and do not attempt to re-ignite the burner for at least one minute.

**LIGHTING PROCEDURE**

1. Push in the control knob and turn to full rate-large flame.
2. Hold in knob and light the hob by depressing the ignition button, which is located on the fascia. It is necessary to hold the knob depressed after the burner has ignited for approximately 10-15 seconds, to allow the thermocouple probe to reach temperature, before releasing the knob.
  - Should the flame go out when the knob is released, the procedure should be repeated holding the knob depressed for slightly longer.
  - If the burner has not lit within 15 seconds the control knob should be released and the burner left for at least 1 minute before a further attempt to ignite the burner.
  - For simmering, turn the knob further anti-clockwise to the low rate position.
  - To turn off: turn the control knob until the line on the control knob is aligned with the zero on the control panel. Always make sure the control knob is in the off position when you have finished using the hotplate burners.

**USING THE ELECTRIC HOTPLATE (DUAL FUEL MODELS)**

1. Ensure power is switched on.
2. The hotplate control is numbered from 1 to 6. To turn it on, rotate the knob either clockwise or anti-clockwise to the required position. Position 1 is the coolest setting.
3. To turn off, rotate the knob until the line or pointer on the knob lines up with the zero on the control panel.

The hotplate is a sealed construction and transfers heat through conduction. For maximum efficiency a correctly sized pan with a flat heavy gauge base should be used. Pan size should be the same or slightly larger (up to 1" / 2.5cm oversize).

Before using your hotplate for the first time, we recommend that you prime it.

**TO PRIME THE HOTPLATE**

1. Switch on the hotplate for a short period, without a pan, to harden and burn off the coating.
2. Use a medium to high setting for 3-5 minutes. A non-toxic smoke may occur during this process.
3. Allow it to cool.

**USING THE GRILL**

Ensure gas cylinder/supply is connected and turned on. In the event of a gas smell turn off at gas cylinder/mains and contact supplier.

**TO LIGHT**

1. Open door.
2. Push in the control knob and turn to full rate/large flame.
3. Push the control knob in and hold whilst pressing the ignition switch.
4. The burner should ignite and the control knob should be held in for 10-15 seconds before release. If the burner goes out, repeat procedure holding control knob for slightly longer.

On first use of the grill, it should be heated for about 20 minutes to eliminate any residual factory lubricants that might impart unpleasant smells to the food being cooked. A non-toxic smoke may occur when using for the first time so open any windows and turn on mechanical ventilators to help remove the smoke.

Although the grill does heat up quickly, a few minutes preheat is recommended.

Flame Failure Device (FFD): the grill burner is fitted with a flame-sensing probe, which will automatically cut off the gas supply in the event of the flame going out. In the event of the burner flames being accidentally extinguished, turn off the burner control and do not attempt to re-ignite the burner for at least 1 minute.

It is normal for the flames on this burner to develop yellow tips as it heats up.

A reversible grill pan trivet enables the correct grilling height to be achieved.

**TO TURN OFF**

1. Turn the control knob until the line on the control knob is aligned with the dot on the control panel. Always make sure the control knob is in the off position when you have finished grilling.



The grill area can get hot when the oven is in use, even if the grill is switched off. Care should be taken when removing pans from the grill, i.e. by use of oven gloves, and by making use of the removable grill pan handle.



The grill pan supplied is multi-functional, for use in grill or oven. The handle design allows removal or insertion while the pan is in use. Always remove the handle when the pan is in use. The grill **MUST** only be used with the door open.

**USING THE OVEN**

Ensure gas cylinder/supply is connected and turned on. In the event of a gas smell turn off at gas cylinder/mains and contact supplier.

**TO LIGHT**

1. Open door.
2. Push in the control knob and turn to full rate (240°C).
3. Push the control knob in and hold whilst pressing the ignition switch.
4. The burner should ignite and the control knob should be held in for 10-15 seconds before release. If the burner goes out, repeat procedure holding control knob for slightly longer.
5. Place the oven shelf in the required position and close the door.
6. Set the control knob to required temperature.

Although the oven heats up quickly, it is recommended that a 10 minute preheat be allowed. The oven should be up to full temperature in about 15-20mins.

**TO TURN OFF**

1. Turn the control knob until the line on the control knob is aligned with the zero on the control panel.

The shelf has been designed to allow good circulation at the rear of the oven and is also fitted with a raised bar to prevent trays or dishes making contact with the back of the oven. To remove a shelf, pull forward until it stops, raise at the front and remove. Installation of a shelf is the reverse of this procedure.



Before first use, heat the oven for about 30 minutes at 200°C, to eliminate any residual factory lubricants that might impart unpleasant smells to the meals being cooked. A non-toxic smoke may occur when using for the first time so open any to help remove the smoke. Always ensure food is properly cooked prior to serving.

**OVEN TEMPERATURE CONTROL**

The temperature in the oven is controlled by a thermostatic gas tap and is variable over the range 130°C to 240°C. Approximate temperatures for the settings on the control knob are shown in the table overleaf. The temperatures indicated refer to the centre of the oven and at any particular setting the oven will be hotter at the top and cooler towards the base.

The variation between top and centre, and centre to bottom is approximately equivalent to one gas mark. Good use can be made of the temperature variation in that several dishes requiring different temperatures may be cooked at the same time. In this way maximum benefit can be obtained from the gas used to heat the oven. Care should be taken not to overload the oven, with adequate spacing being used to allow free circulation for heat.

**COOKING GUIDELINES**

Although the oven heats up quickly, it is recommended a 10 minute preheat be allowed. The oven should reach full temperature in 15-20 minutes.

When roasting with aluminium foil, care must be taken that the foil does not impair circulation or block the oven flue outlet.

GAS MARK	TEMPERATURE (CENTRE OF OVEN)			DISH
1/4 - 1/2	265 - 275°F	130-135°C	Very Cool	Meringues
1	285	140	Cool	Stewed Fruit
2	300	150	Cool	Rich fruit cake, rice pudding
3	330	165	Warm	Baked custard, shortbread fingers
4	355	180	Moderate	Victoria sandwich
5	385	195	Fairly Hot	Whisked sponges, ginger nuts
6	410	210	Hot	Short crust pastry
7	430	220	Hot	Bread, scones, flaky pastry
8	445	230	Very Hot	Puff pastry
9	465	240	Very Hot	Quick browning

### DOS AND DON'TS

DO read the user instructions carefully before using the appliance for the first time.

DO allow the oven to heat before using for the first time, in order to expel any smells before the introduction of food.

DO clean the appliance regularly.

DO remove spills as soon as they occur.

DO always use oven gloves when removing food shelves and trays from the oven.

DO check that controls are in the off position when finished.

DO read the user instructions carefully before using the appliance for the first time.

DO NOT allow children near the cooker when in use. Turn pan handles away from the front so that they cannot be caught accidentally.

DO NOT allow fats or oils to build up in the oven trays or base.

DO NOT use abrasive cleaners or powders that will scratch the surface of the appliance.

DO NOT under any circumstances use the oven as a space heater.

DO NOT put heavy objects onto open grill and oven doors.

DO NOT allow the door to fall down: lower it by hand.



Ensure that the ceramic ball mixer tap arm is clear from the oven lid before raising it. Failure to do so could accidentally switch on the tap when lifting the glass lid.

### MAINTENANCE AND SERVICING

This appliance needs little maintenance other than cleaning. All parts should be cleaned using warm soapy water. Do not use abrasive cleaners, steel wool or cleansing powders. When cleaning the burner ring it is essential to ensure that the holes do not become blocked. The control knobs are push fit and can be removed for cleaning. They are interchangeable without affecting operation.



All servicing must be carried out by an approved competent person. After every service the appliance must be checked for gas soundness.

### LEAKS



If a smell of gas becomes apparent, the supply should be turned off at the cylinder IMMEDIATELY.

- Extinguish naked lights including cigarettes and pipes.
- Do not operate electrical switches.
- Open all doors and windows to disperse any gas escape.
- Never check for leaks with a naked flame; leak investigation should be carried out using a leak detector spray.
- Check the gas is not escaping from an unlighted appliance.

### SERVICE

The cooker must be serviced at least once every 12 months. All servicing must be carried out by an approved competent person. Before any service work is started, the appliance should have been left to cool and be disconnected at the mains socket. After each service the appliance must be checked for gas soundness.

For service, please contact your authorised local service agent giving details of the model and serial number on the data badge plus date of purchase.



Some Bailey caravan models have both a worktop lid and glass lid covering the hob burners. Please be aware that both the glass and worktop lids may become hot during the use of the grill and/or oven. Therefore Bailey and Thetford strongly advise you lift both lids up when using the grill and/or oven to avoid any potential product/injury issues

**Beginners Guide Video,  
Scan to view:**  
Cooking equipment



## CARBON MONOXIDE ALARM

A Kidde 7CO battery-operated alarm is fitted near to the ceiling in your caravan.

### What is Carbon Monoxide?

Carbon monoxide (CO) is a highly poisonous gas with no taste, colour or smell.

Carbon monoxide is a cumulative poison.

Long-term exposure to low levels may cause symptoms.

This Kidde alarm is time-weighted - the higher the level of CO, the sooner it will alarm.

### Alarm levels (as defined by EN50291-1:2010)

PPM Parts Per Million	Time until Alarm
50	60-90 minutes
100	10-40 minutes
300	within 3 minutes

### The table below shows the effects of different levels of CO poisoning on the body

PPM Parts Per Million	Effects on Adults
100	Slight headache, nausea, fatigue (flu-like symptoms)
200	Dizziness and headache within 2 - 3 hours
400	Nausea, frontal headache, drowsiness, confusion and rapid heart rate. Risk to life after over 3 hours of exposure
800	Severe headaches, convulsions, vital organ failures. Death possible within 2 - 3 hours



If you recognise any of the above symptoms consult your doctor immediately.

Young children, elderly and pets are more susceptible to the dangers of CO. Your Kidde alarm is designed to detect CO

gas. It is not designed to detect smoke, fire or other gas such as natural gas. Individuals with certain specific medical conditions may need an alarm that operates below 30ppm. If this applies consult your doctor.



Ensure that all family members are familiar with the symptoms of CO poisoning and how your alarm works

### Switching on Your CO Alarm

1. Remove the batteries from the pack and insert them into the battery compartment. Make sure that you fit the batteries correctly to the polarity markings (+ or -) shown within the battery compartment. If correctly installed, the alarm will give a short beep.
2. To test the alarm, press the test button. The alarm will beep once followed by 4 loud pulses, then a brief pause and then 4 more pulses, ending with a single beep.
3. Check that the green LED flashes at 30 second intervals to show that the alarm has power. This is easiest to see in a dark area, or with lights switched off.

### Testing

Test your alarm each week by pressing the test button. The alarm will beep once followed by 4 loud pulses, then a brief pause and then 4 more pulses, ending with a single beep. During this test sequence, the red LED will flash for 10 seconds. This confirms that the alarm is powered up and working.

### Re-setting the Alarm

If the alarm sounds, the test / reset button will silence the alarm unless it is still detecting dangerous levels of CO. The green light will then flash every 30 seconds to indicate that the alarm has power.

### Maintenance of Your Alarm

To keep your alarm in good working order:

- Test every week
- Vacuum regularly to remove dust
- Keep away from solvents or detergents
- Avoid spraying air-freshener, hair-spray near the alarm
- Do not paint the alarm. If decorating or using adhesives close to the alarm, remove it temporarily



## Recognising Alarm Signals and Warnings

Feature	What it means	Required action
Green LED flashes every 30 seconds	Normal operation	None
The alarm chirps every 60 seconds and the red LED flashes	Low batteries	Replace batteries as soon as possible
Alarm chirps twice every 30 seconds and the red LED flashes twice	End of life of the alarm	Replace the alarm
Alarm chirps every 30 seconds and red LED flashes every 30 seconds	Fault	Replace the alarm
Red LED on and constant tone	Malfunction	Replace the alarm
Loud, continual alarm (4 beeps - 5 second pause - 4 beeps...) and the red LED flashes	Dangerous levels of CO have been detected	Follow emergency procedures

### What to do if Your Alarm Sounds

#### Carbon Monoxide Alarm Procedure



**WARNING!** Activation of the alarm indicates the presence of Carbon Monoxide (CO) which can kill you.

Based on recommendations from EN 50292, follow these steps if alarm sounds (4 loud audible pulses followed by a pause for 5 seconds):

1. Keep calm and open all doors and windows. Turn off all fuel-burning appliances if possible.
2. If the alarm continues to sound, even after being reset (where appropriate), then evacuate the premises, alerting other occupants to the risk. Leave doors and windows open. Do not re-enter the premises.
3. Get medical help for anyone suffering the effects of CO poisoning, and advise that CO inhalation is suspected.
4. Never restart the source of the CO problem until it has been corrected. Never ignore the sound of the alarm! If the alarm is sounding, pressing the test/reset button will terminate the alarm.

If the CO condition that caused the alert in the first place continues, the alarm will reactivate.

If the unit alarms again within six minutes, it is sensing high levels of CO which can quickly become a dangerous situation.

### Replacement of Batteries

Under normal operating conditions, the batteries will last a minimum of one year.

**NOTE:** Constant exposures to extreme temperatures and huminities may affect battery life. These batteries can be purchased from your local retailer.

**End-of-life** - This alarm will chirp twice every 30 seconds with a red LED flash after at least 10 years operation to let you know it has reached its end of life. A replacement needs to be purchased.

### Useful Contact Information

Kidde Helpline  
 UK - 0800 917 0722  
 Ireland - 1800 818 601

Kidde Website:  
[www.kiddesafetyeurope.co.uk](http://www.kiddesafetyeurope.co.uk)

## SMOKE ALARM

The smoke alarm is operational once the battery is connected. When products of combustion are sensed, the unit sounds an alarm until the air is cleared.

### FEATURES

- Battery operated.
- The operating light (red LED) flashes every 40 seconds confirming that the unit is powered.
- Low battery warning: the unit will emit an audible "chirp" once every 40 seconds for 7 days before the battery needs to be replaced. Failure to replace the battery will result in insufficient power to alert you in a real fire situation.
- Sensitivity test button. This tests the sensitivity, circuitry, battery and horn.
- Loud alarm



Test smoke operation after vehicle has been in storage, before each trip and at least once a week during use.

Your alarm requires one 9 volt battery. Under normal use, the battery should last one year.

### SIMPLE MAINTENANCE

Clean your smoke alarm once every three months to help keep the unit working correctly. Gently vacuum using a soft brush attachment.

Problems are indicated by two events:

The alarm does not sound upon pressing the test button. The operating light remains steadily on or off (i.e. does not flash every 40 seconds, when the unit is not sounding).

Try the following:

- Inspect for obvious damage.
- Check that the unit contains recommended battery type.
- Check that the battery cover has been removed.
- Check that the battery is properly connected.
- Gently vacuum as recommended above.
- Replace battery.

If these procedures do not correct the problem, do NOT attempt repairs; replace the alarm.

## BATHROOM CARE

Do not expose the bathroom plastic fittings to cleaning products or abrasive material containing concentrated perfumes, body oil, linseed oil, gritty or abrasive substances, solvents (white spirits, antifreeze etc). These may cause permanent damage to the material. Always clean the bathroom straight away after use with warm soapy water and a soft cloth. Stubborn stains may be removed with a solution of lemon juice and water, at a solution of 1 part water to 1 part lemon juice.

Thetford bathroom cleaner is suitable for cleaning the shower and vanity unit plastic items (sinks, shower trays, Thetford toilets etc).



Domestic cleaning products are not to be used to clean the shower/vanity unit plastic items. Some mouthwash can cause plastic items to crack and for this reason should not be used.

### BATHROOM SHOWER TAP

Your shower tap has a high quality finish and should be treated with care to preserve the visible surfaces.

All surface finishes will wear if not cleaned correctly; the only safe way to clean your mixer is to wipe with a soft damp cloth.

Stains can be removed using washing up liquid. All bathing powders and liquids will damage the surface of your fitting, even the non-scratch cleaners.

### MIRRORS

Cleaning: it is best to clean mirrors with a cleaner that does not contain ammonia. If you are not sure of the ingredients, spray a clean lint-free cloth with the cleaner so as not to get the liquid near to the edge of the mirror which is where ammonia would cause the most harm.

- Use a soft, dust-free cloth.
- Warm water- try bottled water if your tap water is mineral rich.
- For stubborn dirt use an oil free steel wool pad, carefully and precisely.
- Spray cleaners on your cloth, not directly onto the mirror.
- Keep the mirror frame dry.
- Never use a razor blade on a mirror, even if the mirror has paint specks on it. Always use hot water first.

- If you find black spots on your mirror you may have damaged the silvering behind the mirror's glass. If this is the case you may be able to cover the spots from the front.
- Moisture along a mirror's edge can seep in and harm the reflective backing.
- Keep in mind that long-term exposure to direct sunlight may damage some mirrors.

### ECOCAMEL SHOWER HEAD

Your caravan is fitted with an Ecocamel shower head.

- It saves water, energy and money.
- It has a wipe clean head to prevent the build-up of lime scale.
- Uses a maximum of 8 litres a minute.

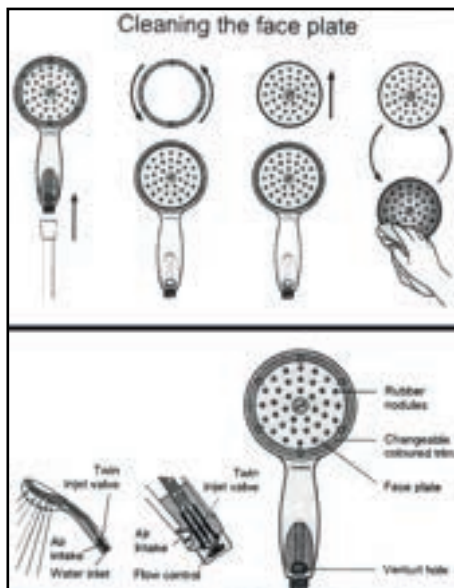

After showering (when the shower is turned off) your Ecocamel shower head simply drains off any excess water through the air intake. Clean your Ecocamel shower head with a damp cloth. Do not use any abrasive or chemical cleaners. Should any scale build up on your shower head's spray plate you can de-scale it by rubbing the nozzles with your thumb.

The Ecocamel shower head will fit all caravan showers and is available from the Bailey Parts department.

## THETFORD TOILET

The toilet is made up of two parts:

- A permanently fixed toilet bowl.
- A waste holding tank that is accessible from the outside. The removable waste holding tank is located under the toilet bowl and can be removed via a door on the outside of the caravan. The Thetford Cassette Toilet is the solution to the sanitary problem in your caravan.

These operating instructions cover Thetford Cassette Toilet C260/262CWE.

Please note that on some models the cistern is not visible.

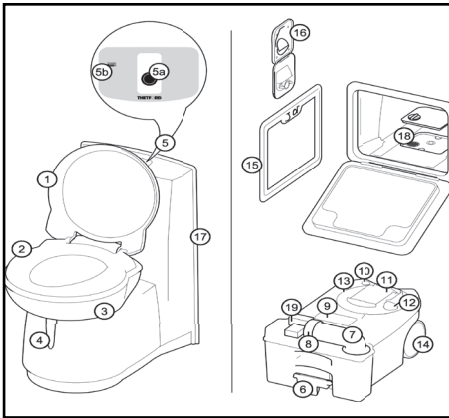

### PARTS

1. Cover
2. Seat
3. Swivelling toilet bowl
4. Blade handle to open and close blade
5. Control panel
- 5a. Electric flush button
- 5b. Waste holding tank level indicator
6. Pull handle
7. Pour out spout
8. Cap with measuring cup
9. Automatic pressure release vent
10. Vent button
11. Sliding cover
12. Blade opener
13. Waste holding tank mechanism
14. Wheel
15. Service door
16. Water fill door
17. Console with flush-water tank
18. Filter for electric ventilator
19. Location waste pump-out system

### USING THE TOILET (STANDARD)

1. Turn the bowl to the desired position with the lid closed and using both hands.
2. To activate the control panel, press the flush-button once. The control panel display will stay activated for approximately 5 minutes. Run some water into the bowl by pressing the flush button again briefly.
3. The toilet may be used with the blade open or closed. To open the blade, slide the blade handle under the toilet bowl sideways. After use, open the blade (if still closed) and flush the toilet by pressing the flush button for several seconds (if necessary re-activate the control panel). Close the blade after use. If your toilet has its own flush-water tank, please make sure that you do not travel with a flush-water tank that is too full. Do not travel with water in the toilet bowl. Failure to adhere to this notice may result in water damage to your caravan.

### CLEANING AND MAINTENANCE

- The toilet should be cleaned and maintained regularly, depending on the amount of use. To clean Thetford toilets, we advise using water and Thetford Bathroom Cleaner. Never use bleach, vinegar or other powerful household cleaners that contain these substances. These may cause permanent damage to the seals and other toilet components.

### TOILET BOWL

1. Squirt Thetford Bathroom Cleaner into the toilet bowl.
2. Flush the toilet bowl with water and wipe down the rest of the toilet with a damp cloth.
3. Clean seat and lid. The seat and lid can easily be removed: lift the seat and lid assembly and pull the round pins (inside the assembly) outwards from the pin holes. After cleaning, replace the seat and lid by positioning the round pins in front of the pin holes and push the lid and seat downwards.
4. To keep your flush-water fresh and to prevent deposits forming in your toilet bowl, add a correct dosage of Aqua Rinse in your flush water tank.

### WASTE HOLDING TANK

To keep your waste holding tank fresh and clean, Thetford has developed a number of different toilet fluids. Thetford toilet fluids suppress smells, reduce formation of gas, promote breakdown of toilet waste and increase the life span of a mobile toilet. We advise a thorough cleaning of the waste holding tank once each season.

For the periodical cleaning of the waste holding tank of your toilet, we suggest the following:

1. Remove the removable mechanism from the waste holding tank by turning it anti-clockwise and rinse it under a tap.
2. Remove the cover plate from the automatic pressure release vent by prising it up using a small screwdriver. Use one hand to push the automatic pressure release vent open while holding the float of the automatic pressure release vent on the inside of the tank with the other hand. Push the float upwards, turn it 180 degrees and remove it from below. Remove the rubber seal underneath the float. Rinse the float and rubber seal under a tap. Replace the rubber seal and float for the automatic pressure release vent using the same method in reverse.
3. The rubber seals in the toilet (the lip seal, the mechanism seal, the automatic pressure release vent seal and the cap seal) should be regularly cleaned with water and treated with Thetford High Grade Seal Lubricant. This will ensure that the seals remain flexible and in good condition. If the toilet is not to be used for any length of time, it is important to treat the seals with Thetford High Grade Seal Lubricant after cleaning.



Never use Vaseline or any vegetable oil except olive oil. These may cause leakage or malfunction. The lip seal is a part of the toilet that is subject to wear. Depending upon the extent and manner of use, the seals will become less effective and will need replacing periodically.

### WINTER OPERATION

You can use your Thetford Cassette Toilet as normal in cold weather as long as the toilet is situated in a heated location. If there is a risk of freezing we advise that the toilet is drained. For environmental reasons the use of antifreeze, such as that used in car radiators, is not recommended.

### PREPARING THE FLUSH TANK

Check the correct dosage of the Thetford flush water tank additive on the packaging.

Add the stated dosage to the flush water tank through the water fill door on the side of the caravan. Fill the flush tank with clean water through the water fill door using a water container. The flush tank holds 8 liters

**Beginners Guide Video,  
Scan to view:  
Thetford toilet operation**



## PREPARING WASTE HOLDING TANK

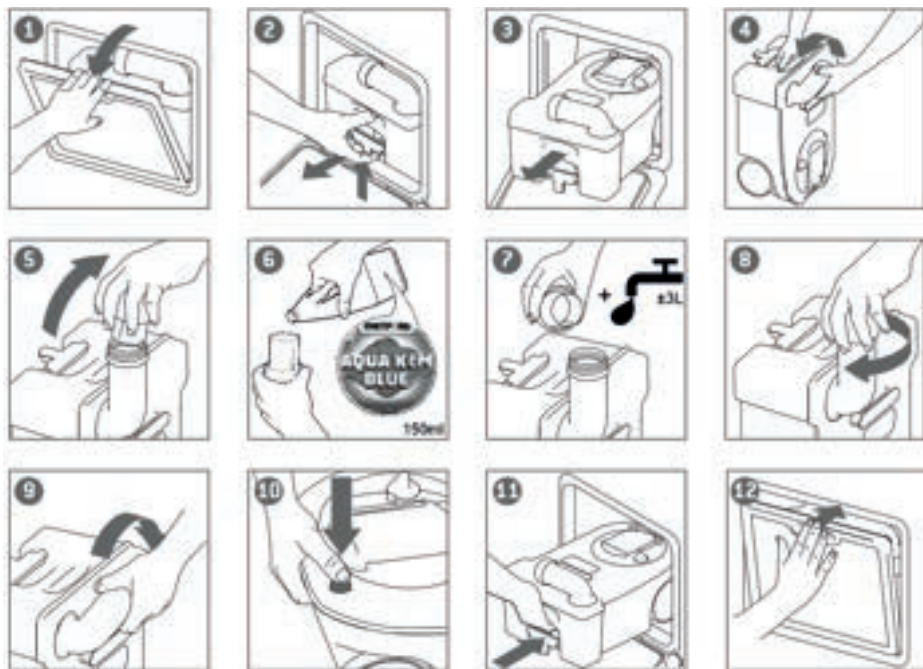

## EMPTYING WASTE HOLDING TANK

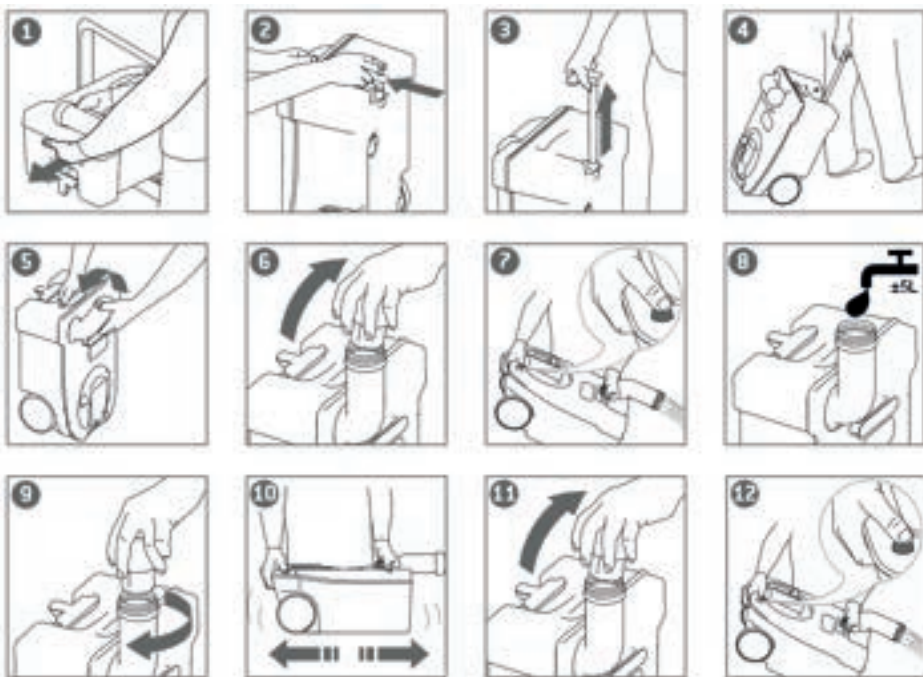

## REFRIGERATOR OPERATION

The refrigerator is equipped to operate on three power modes:

- Mains voltage (230v AC)
- Direct-current voltage (12v DC)
- Gas (liquid gas propane/butane).

When the appliance is first put into operation, there may be a mild odour which will disappear after a few hours.

Park the vehicle level, particularly when starting up the refrigerator and filling with food before starting a journey.

The cooling unit is silent in operation.

The refrigerator will take several hours to reach its operating temperature in the cooling compartment. The freezer compartment should be cold about one hour after switching on the refrigerator.

### CLEANING

Before starting up the refrigerator it is recommended that you clean it inside and repeat this at regular intervals. Use a soft cloth and lukewarm water with a mild detergent. Always dry thoroughly. Keep the condensation water drain channel free of deposits.

To avoid material alterations, do not use soap or hard, abrasive or soda-based cleaning agents. Do not allow the door seal to come into contact with oil or grease.

### MAINTENANCE

In compliance with the applicable regulations, please note that the gas unit and the connected ventilation ducts must be checked by authorised technical personnel after first use and after every other year for compliance with the European Standard EN 1949. A test certificate has to be issued. It is the user's responsibility to arrange this test.

The gas burner must be inspected and cleaned as necessary at least once a year. When using liquefied petroleum gas (tank or refill cylinders) the maintenance interval is reduced to half yearly or quarterly. Keep the evidence of maintenance work carried out on your refrigerator. Work on gas and electrical equipment shall be carried out by qualified personnel only.

### DEFROSTING

As time goes by, frost builds up on the fins inside the refrigerator. A layer of frost thicker on one side may occur and does not represent a malfunction. When this layer of frost is about 3 mm thick, the refrigerator should be defrosted.

1. Switch off the refrigerator, as described in section Shutting off the refrigerator.
2. Remove all food and the ice cube tray.
3. Leave the refrigerator door open to allow air to enter and to prevent formation of mildew.
4. After defrosting (freezer compartment and fins free of frost) wipe both cooling compartments dry with a cloth.



Water thawing in the main compartment of the refrigerator runs into an appropriate container at the back of the refrigerator. From there, the water evaporates.

### ENVIRONMENTAL NOTICES

Ammonia (a natural compound of hydrogen and nitrogen) is used in the cooling unit as a coolant. Non-ozone-hazardous cyclopentane is used as a propellant for manufacturing PU foam insulation.

Do not dispose of batteries in domestic waste. Take your used batteries to a collection point.

### ENERGY SAVING TIPS

- At an average ambient temperature of 25°C, it is sufficient to operate the refrigerator at middle thermostat setting. Where possible, always store pre-cooled products.
- Do not expose the refrigerator to direct sunlight or any other heat source (e.g. heater).
- Ensure that air circulation of the refrigeration unit is not obstructed.
- Arrange the shelves evenly in the refrigerator (in the cooling compartment) in order to achieve the most efficient use of energy. Do not overfill the storage grids and compartments to prevent obstructing the internal air circulation.
- Maintain a clearance of approx. 10 mm between chilled products and post-evaporator 'cooling fins'.



- Defrosting at regular intervals saves energy (see section Defrosting).
- Open the refrigerator door only for a short period of time when removing products.
- Run the refrigerator for about 12 hours before filling it.

### DECLARATION OF CONFORMITY

The current Declaration of Conformity can also be requested directly from Dometic GmbH, Siegen.

### SAFETY INSTRUCTIONS

#### APPLICATION ACCORDING TO REGULATIONS

This refrigerator is designed for installation in recreation vehicles such as caravans. The refrigerator is to be used solely for storing foodstuffs.



The refrigerator is not suitable for the proper storage of medication. Please observe in addition the instructions in the medication package inserts.

#### USERS RESPONSIBILITY

Anyone operating the refrigerator must be familiar with the safe handling and understand the advice in these operating instructions.

This appliance is not intended for use by persons (including children) with reduced physical, sensory or mental capabilities, or lack of experience and knowledge, unless they are supervised or have been given instruction concerning use of the appliance by a person responsible for their safety. Children should be supervised to ensure that they do not play with the appliance. Cleaning and user maintenance shall not be completed by children.

#### WORKING UPON AND CHECKING THE REFRIGERATOR



Work on gas equipment, exhaust system and electrical facilities must be carried out by authorised personnel only. Substantial damage to property and/or injury to persons can arise through unprofessional procedures.



Never use an unshielded flame to check gas bearing parts and pipes for leakage. This is a danger of fire or explosion.



Never open the absorber cooling unit. It is under high pressure. There is a danger of injury.

#### INFORMATION ON COOLANT

Ammonia is used as a coolant. This is a natural compound also used in household cleaning agents (1 litre of Salmiak cleaner contains up to 200g of ammonia, about twice as much as used in the refrigerator). Sodium chromate is used for corrosion protection (1.8% by weight of the solvent).

In the event of leakage (easily identifiable from the strong odour), proceed as follows:

- Switch off the appliance.
- Air the room thoroughly.
- Inform authorised customer services.



For your safety it was ascertained in an expert's report that no impairment of health exists when the coolant is discharged.

#### APPLIANCES WITH ELECTRONICS (MES/AES)

Car manufacturers often use a battery management system, which provides the caravan with constant voltage in trailer mode. If the car and trailer remain parked for more than 30 minutes with the engine switched off, the battery management system automatically switches off the permanent positive supply to the caravan (to prevent the battery from discharging). Fridges with control electronics (MES/AES) are then inoperative.

Check whether your drawing vehicle is equipped with a battery management system.

A permanent 12v power supply must be guaranteed for operation of the MES/AES fridges.

#### OPERATING THE REFRIGERATOR WITH GAS

It is imperative that the operating pressure of the pressure reducer on the gas system corresponds to the data specified on the rating plate of the refrigerator. Compare the operating pressure of the rating plate with the data specified on the pressure reducing valve of the liquid gas cylinder.



Dometic refrigerators are equipped for a connection pressure of 30mbar.



Operating appliance with Gas is not permitted

- At petrol stations
- On ferry boats, and on board motor rail trains
- While transporting the caravan by transporter or breakdown vehicle

### IF YOU SMELL GAS

- Open all windows and leave the room.
- Do not operate any electrical equipment and prevent the use of naked flames.
- Do not operate any electrical equipment and prevent the use of naked flames.
- Contact authorised specialist personnel for advice.

## SAFETY INSTRUCTIONS WHEN STORING

### FOODSTUFFS

No refrigerator of any kind can improve the quality of the food; refrigerators can only maintain the food's quality for a short duration as from the time of storing it.

Please observe the following particular conditions for storing food in a refrigerator that is built into a vehicle:

- A change in the climatic conditions such as temperature fluctuations.
- High temperatures inside the vehicle when it is closed and parked in direct sunlight (temperatures are possible up to 50°C).
- A refrigerator built in behind a window and exposed to direct sunlight.
- Storing the products too soon, i.e. shortly after starting up the appliance for use.
- Use of the refrigerator during travel with the power supply of 12v DC.
- Fluctuations in the power supply at the parking place when using the energy type 230v AC (mains voltage).

Under these particular conditions the refrigerator cannot guarantee reaching the temperature needed for perishables.

Perishables include all products with a stipulated use-by date and a minimum storage temperature of +4°C or less, especially for meat, poultry, fish, sausages, pre-packed foods.

- Pack raw and cooked foods separately (e.g. in containers, aluminium foil, etc.).
- Only remove the outside packaging of single packs if all the necessary information, e.g.

the use-by date, can also be read on the single packs.

- Please observe the instructions and information regarding the use-by date on the outside packaging of the food.
- Do not leave cooled goods outside the refrigerator for too long.
- Place the foods with the next use-by date at the front, accordingly.
- Pack away any left-over food and eat at the first opportunity.
- Wash your hands before and after handling any food.
- Regularly clean the inside of the refrigerator.
- Please observe section Cleaning of this instruction.



The cooling unit's performance is influenced by ambient temperatures. Please select the medium setting for ambient temperatures between +15°C and +25°C (refer to Setting of cooling compartment temperature). The unit operates within its optimum performance range.

The refrigerators work according to the absorption principle. For physical reasons, an absorption system responds slowly to changes made by the thermostat controller, by loss of cooling energy through opening the door or during storing food. The devices meet the cooling performance requirements of the Climatic Class SN acc. to EN/ISO 7371 in the temperature range of +10°C to +32°C ambient temperature.

Cold air can restrict the performance of the unit. Install the winter covers if you discover any loss of cooling performance when outdoor temperatures are low (see Operation during low outside temperatures). For ambient temperatures exceeding +32°C for a longer period of time, it is recommended installing an additional fan.

### REFRIGERATOR OPERATION

The refrigerator is equipped to operate on three power modes:

- Mains voltage (230v AC)
- Direct-current voltage (12v DC)
- Gas (liquid gas propane/butane)

Select the desired power mode by the energy selector switch (battery igniter type

models) or the energy selector button (MES, AES). Appliances with automatic energy selection (AES) are additionally provided with "automatic mode" function. Then the AES system automatically selects the best energy source for each particular situation.

- When the appliance is first put into operation, there may be a mild odour which will disappear after a few hours.
- Park the vehicle level, particularly when starting up the refrigerator and filling with food before starting a journey.
- The cooling unit is silent in operation.
- The refrigerator will take several hours to reach its operating temperature in the cooling compartment. The freezer compartment should be cold about one hour after switching on the refrigerator.



We recommend maintenance following an extended shut-down of the vehicle. Please contact our customer services.

- For physical reasons, gas ignition faults could occur starting from an altitude above sea level of approx. 3280ft. / 1000m.
- On the initial refrigerator start-up or after a cylinder change, air may be trapped in the gas line. To purge the air from the lines, switch on the refrigerator and any other gas appliances (e.g. stove) for a short time. The gas ignites without delay.
- Each refrigerator with manual ignition is equipped with an automatic flame safety valve which interrupts the gas supply automatically after approx. 30 seconds when the flame has extinguished.



As a basic rule, gas operation is prohibited in petrol stations

Bailey use various models of refrigerator depending on size and layout of the caravan. Please see relevant section for the model of fridge fitted.

## ELECTRICAL OPERATION

### 12V VOLTAGE (ON BOARD POWER SUPPLY)

The refrigerator will only operate when the caravan is attached to tow vehicle and the tow vehicle engine is running.

Do not leave switch in 12v position when not towing as the control system on digital fridge will slowly drain the caravan battery over a period of time.

### MAINS POWER 230v

This operation should only be selected where the supply voltage of the connection for power supply corresponds to the value specified on the data plate. Any difference in values may result in damage to the appliance.

### GAS OPERATION (LIQUID GAS)

- The refrigerator must be operated using liquid gas (propane, butane) (no natural gas or town gas).
- When using LPG gas, please consider that the burner needs cleaning at shorter intervals due to the gas combustion method (2 - 3 times per year recommended).
- In Europe, gas operation is permitted while travelling only on the condition that the gas system of the vehicle is equipped with a hose rupture protection. The national regulations of the respective country must be observed.

## DOMETIC 10 SERIES FRIDGE

The LED display has the following operating and display elements.

Symbol	Description
	ON/OFF button
	Fault indication
	Operating with DC power
	Operating with gas
	Operating with AC power
<b>A</b>	Automatic mode
	Temperature indication
	Energy selection button
	Temperature selection button

### SWITCHING ON THE REFRIGERATOR

- Press on/off button for 2 seconds
  - The refrigerator starts with the last selected settings.

### SWITCHING OFF THE REFRIGERATOR

- Press on/off button for 4 seconds
  - A beep sounds and the refrigerator switches off.

### OPERATING THE REFRIGERATOR

#### CONTROL

- Repeatedly press mode button, until the LED indicates the desired operating mode.
- Repeatedly press temperature selection button, until the desired temperature level is set.

### SETTING THE COOLING CAPACITY

- Repeatedly press temperature selection button until the desired temperature level is selected.

#### NOTE

For ambient temperatures of +15 °C to +25 °C, select the average cooling capacity.

For further information on the operation of the Dometic 10 series fridge please refer to the appliance user manual

**Beginners Guide Video,  
Scan to view:**  
Dometic Series 10 fridge



## Thetford N Series Fridge

### Control Panel

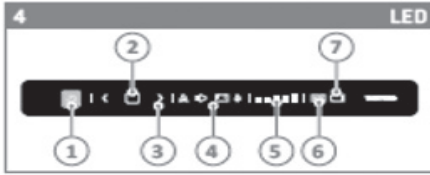

1. On/off button
2. Confirmation button
3. Arrow buttons
4. Energy sources
5. Cooling level indicators
6. Anti-condensation
7. Battery empty (optional)

### Switching on

Push the on/off button and hold it for 1 second. The light in the on/off button turns blue and the last selected settings with light up.

To select energy source

1. Push the confirmation button (2) and hold it for 2 seconds until the energy source symbols start to blink
2. Push the arrow buttons until the desired source is selected
3. Push the confirmation button with quick touch (press and let go) to confirm your section

### To select cooling level

1. Push the confirmation button (2) and hold it for 2 seconds until the energy source symbols start to blink
2. Push the confirmation button again. The cooling level indicators start to blink
3. Push the arrow buttons to select the desired cooling level
4. Push the confirmation button to confirm your section. Your control panel should now confirm and turn off, leaving a blue light in the no/off button

For further information on the Thetford N Series fridge, please refer to the appliance user manual

**REFRIGERATOR TROUBLESHOOTING GUIDE**

<b>FAILURE: THE REFRIGERATOR DOES NOT COOL SUFFICIENTLY</b>	
<b>Possible Cause</b>	<b>Action you can Take</b>
Inadequate ventilation to the unit	Check that ventilation grilles are not covered
Thermostat setting is too low	Set thermostat to higher level
The condenser is heavily frosted	Check that the refrigerator door closes properly
Too much warm food has been stored inside within a short period of time	Allow warm food to cool down before storage
The appliance has been running for only a short period of time.	Check whether the cooling compartment works after approx. 4-5 hours.
Ambient temperature is too high	Regularly remove ventilation grilles.
<b>FAILURE: THE REFRIGERATOR DOES NOT COOL IN GAS OPERATION MODE</b>	
<b>Possible Cause</b>	<b>Action you can Take</b>
Gas cylinder empty	Change the gas cylinder
Is the upstream shut-off device open?	Open Shut-off valve
Air in the Gas Pipe?	Switch off the appliance and start again. Repeat this procedure 3-4 times, if necessary
<b>FAILURE: THE REFRIGERATOR DOES NOT COOL IN 12V OPERATION</b>	
<b>Possible Cause</b>	<b>Action you can take</b>
On-board fuse defective	Fit new fuse.
On-board battery discharge	Check battery, charge it.
Engine not running	Start engine
Heating element defective (please also refer to failure indication).	Please inform the Dometic Customer Services.
<b>FAILURE: THE REFRIGERATOR DOES NOT COOL IN 230V OPERATION</b>	
<b>Possible Cause</b>	<b>Action you can take</b>
On-board fuse defective	Fit a new fuse.
Vehicle not connected to mains supply voltage	Make connection to a mains power supply
Heating element defective (please refer to failure indication)	Please inform the Dometic Customer Services



# PRIMA

LEISURE ACCESSORIES

Be prepared for all your adventures with a range of bespoke accessories made to fit your Bailey caravan, ask your local Bailey retailer or visit [www.primaleisure.com](http://www.primaleisure.com)



## BESPOKE ACCESSORIES FOR YOUR CARAVAN



## STAINLESS STEEL SINK

Stainless steel sinks need little maintenance other than cleaning immediately after use.

Most deposits can be removed by washing with soap or mild detergent and hot water, followed by a clean water rinse and drying with a soft cloth to prevent water spotting.

For more tenacious deposits a non-abrasive multi-purpose cream cleaner should be used, followed by a clean water rinse and drying.

Tannin stains can be removed by a solution of washing soda and water applied with a soft cloth/sponge followed by a clean water rinse to remove any residues, and drying with a soft cloth.

When cleaning with anything other than water be careful not to get the solution onto your kitchen worktop.

Always avoid bleach and trigger-dispense products and never use wire wool or leave wet cloths, pads or containers on the surface as they may form water marks.

## Toilet Compartment Sink

### OPAQUE FINISH

For the usual daily cleaning of the opaque sink, use a scrub sponge with a powder abrasive detergent (for example, scouring powder).

1. Rinse with water.
2. Use a microfibre cloth to wipe.

### GLOSSY FINISH

For the usual daily cleaning of the glossy sink, use a damp cloth or sponge with liquid soap, which does not contain abrasive particles.

1. Rinse with water.
2. Use a microfibre cloth to wipe.



Do not use abrasive detergents, alcohol, acetone or solvents, because they will damage the material. In case of accidental contact with such solvents, quickly rinse with water.

## SOFT FURNISHINGS

### CARPET

When cleaning the interior of your caravan please remove the carpet from the vehicle. Vacuum the carpets to take the dirt out of the pile.

For general cleaning use a dry shampoo, following the product's directions.



Never put the carpet in a washing machine or a tumble dryer.

### UPHOLSTERY CLEANING AND CARE

The care guide is to help you care for your upholstery and maintain the product for many years.

You may find your upholstery a little firm at least to begin with, this is perfectly normal as all foam and filling composites will naturally soften in time. This softening does not constitute as a fault under the warranty.

Fabrics with a pile may appear to have a difference in shades, this is due to the direction of the pile and how the light reflects. This is not a fault, But part of the charm of the fabrics. Regular care with a soft brush will ease the pile back and reduce the effect of the pile being flattened over time.

Fabric will stretch, move and develop creases/ wrinkles during use, these are expected and are completely normal during the lifetime of the product.

Most fabrics will show signs of wear over time this is due to friction, another sign of use can be little balls of fuzz which could appear on the fabric surface, this can be different for each fabric as each fabric will be made up of different yarns and weaves, all these are signs of normal use of the product and occur naturally and is not considered a defect.

It is important all cushions/upholstery are regularly "Dressed", this is achieved by a good plumping of the cushions/upholstery to ensure the cushions revert to their shape. All cushions and arm pads should have the creases and wrinkles smoothed out daily. Without "Dressing" and "Smoothing" the cushions it could give the appearance of flat/ miss shaped or making the fabric appear loose or baggy. This is not a defect but part of the care of the product/s.

Please ensure all cushions/upholstery are always placed in the correct position during use.

Vacuuming or using a soft brush frequently on products helps to eliminate dirt and dust particles which will also keep the product in tip-top condition.

Avoid prolonged exposure in direct sunlight or heat source as this will have an adverse effect on the product/s.

Dry clean all products only, if a spillage occurs, we advise removing the excess with a soft absorbent cloth or paper towel. Do not soak or rub/scrub any fabrics, we always advise contacting a professional cleaning services for advice

### WINTERISATION AND STORAGE

Mattresses are made from fire retardant fabric and are of a honeycomb constriction based on solid foam with diamond cut out to perform like a spring. It is recommended that mattresses be stored on edge during winter. Try to keep your cushions away from direct sunlight.

### CURTAINS

It is recommended that the curtains in your caravan are washed on a delicate cycle at 30°C. This will not damage the clip glides. Shrinkage may be caused should you decide to dry clean your curtains.

Curtains should not be left closed during daytime hours otherwise some fading may occur.



## WINDOW BLINDS

### PLEATED WINDOW BLINDS

Please note the blinds should not be closed (down position) when the vehicle is travelling or when in storage for prolonged periods.

The sun screen is housed at the bottom and the fly screen at the top of the blind. To open hold the cross bar and pull up or down. Both blinds can be fully extended to totally cover the window or can meet at any position to give sun shading/privacy and protection from insects entering the vehicle.

The blinds are pre-set to the correct tension. If re-tensioning is required please follow these steps:

- The blind needs to be taken down from the wall by unscrewing the 4 corner screws.
- Lay the blind face down on a table with the cross bars of both blinds meeting in the middle.
- The black cords re-tension the fly screen and the white cords re-tension the sun screen.
- The cords are fixed at either side with a screw. Loosen this screw and gently pull the cord 5mm tighter and repeat on the other side ensuring the cross bar is level.
- Test the tension. This process can be repeated if necessary.

### CLEANING

The plastic profiles can be cleaned with a non-abrasive cleaner and damp soft cloth. The blinds should only be dusted lightly with a soft cloth.

### ROLLER BLIND

#### FUNCTION

Both the sun screen and the fly screen are stored at the top. The sun screen can be pulled down and fixed at any of the stops in the side supports. The fly screen can be pulled down and fixed at the bottom of the side supports. When released from the fixing points the blinds will automatically retract.

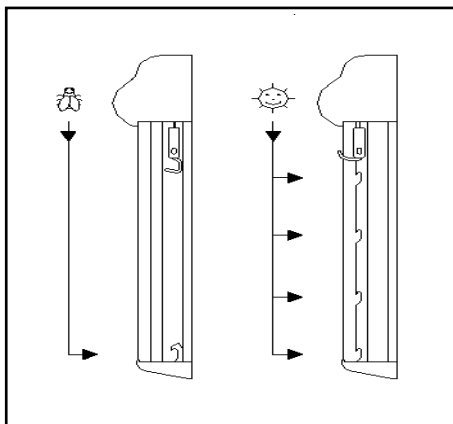

### RE-TENSIONING

If this is required on either blind the screw head located on the side of the roller should be turned once and the blind tested. If the tension is still not correct further turns may be required.

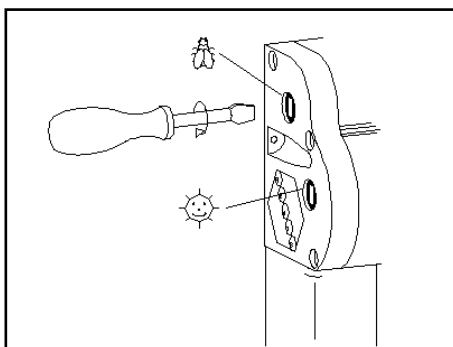

### MAINTENANCE

The sun screen can be wiped with a non-abrasive cleaner as can the cassette holder. The fly screen can be cleaned with a soft brush.

Neither blind should be closed (in the down position) when the vehicle is being towed or in storage for prolonged periods.



Do not allow the blinds to retract too quickly. Uncontrolled retractions will lead to damage

## GENERAL CARE AND MAINTENANCE OF YOUR CARAVAN

### EXTERIOR

The exterior of your caravan is very durable and easy to clean owing to its high gloss properties. To maintain a showroom finish, you will need to wash the caravan and its parts frequently, using a suitable cleaner. Avoid using strong alkaline (e.g. tri-sodium phosphate) or acidic cleaners or abrasives.

Waxing the components once or twice a year with a good grade paste wax will help to maintain the colour and finish.

### CLEANING/USAGE INFORMATION

- Wash the caravan by hand, using a sponge and plenty of cleaning solution to avoid scratching.
- Always rinse away any suds/cleaner from your caravan.
- Dry the vehicle with a chamois or microfibre cloth.
- It is imperative to ensure that the area surrounding the rooflight is completely dried. This will avoid both condensation and damp collecting around said roof light.
- Where possible position the vehicle nose down for a short period to avoid water pooling and collecting on the roof area.
- Do not apply a carnauba-based wax to the vehicle.
- Do not use a mechanical brush washing system such as a car wash.
- Never pressure wash your vehicle.
- Do not use solvents.
- Do not use acrylic cleaners.



Under no circumstances should you use any abrasive agents, methylated spirit, white spirit or other solvents to the exterior of your caravan.

- No touch up painting should be carried out prior to consulting a Bailey Service Centre for approved methods.
- All items stored in the gas bottle storage locker must be secured to prevent impact damage to the inside of the body panel when the caravan is being towed.
- Do not allow any chemicals to spill or leak

into the gas box floor. Before placing items in the cradle ensure that the tray is clean and free from any debris. Cleaning should only be carried out with warm soapy water.



The use of high pressure water jets to clean your caravan will invalidate your warranty.

### ACRYLIC WINDOWS

The windows fitted to your Bailey caravan are manufactured from high quality acrylic using the latest plastic processing methods.

For cleaning, use generous amounts of water to wash away dust and road grit etc. Then use a soft cloth and warm soapy water and gently remove the remaining dirt. Avoid abrasive cleaning materials and detergents.

As with all plastic materials, acrylic should not be allowed to come into contact with chemicals such as paint remover, fly spray, acetone, dishwasher detergent and car cleaning detergent.



Never polish with a dry cloth. During high sun do not close the window blinds completely and open the windows into the ventilation position. While the caravan is in motion please ensure that the windows are fully closed.

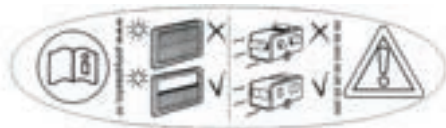

Dependent upon the temperature inside the caravan compared to outside, condensation may be experienced between the window panes. This is a perfectly normal occurrence as the windows are not sealed units. To disperse condensation, remove the bungs using a pair of blunt end tweezers in the corners of the window unit (preferably on a warm day) until the condensation disperses and then replace the bungs.

## WINDOW CATCHES AND STAYS

### OPENING

- Depress centre to release lock (if fitted)  
Turn catch arm to the vertical position to open.
- A night vent position is available by depressing the locking knob and locating the catch into the middle catch plate slot.
- The windows are held open by an adjustable arm. Tightening the knob in a clockwise direction will hold the window open in the desired position.



Always ensure the knob is unscrewed before closing the window. Failure to do so may cause damage to the window stay arm. Always ensure that windows are fully closed during wet weather and not on night vent settings.

### HUMIDITY

Air contains moisture.

The higher the temperature of the air the more water it is able to hold. Air at 20°C can hold a lot more moisture than air at 10°C. The term "relative humidity" describes the amount moisture air contains at a given temperature. 100% relative humidity means the air is holding as much moisture as possible at the current temperature.

The more humid the air in your caravan, the more energy it takes to heat because the water in the air is also being heated.

A good range of indoor humidity for comfort and health is between 30% and 60% during cooler months of the year. Mould is likely to occur if the relative humidity indoors is 70% or more for long periods of time. Keeping humidity levels under 50% also helps to minimise or control dust mites.

### CONDENSATION

Water vapour condenses on cold surfaces when the humidity is high inside the van but it is cold outside.

Possible causes of condensation

- Lack of adequate heating or ventilation.
- Water ingress from the outside through leakage, seepage or open windows.
- High levels of moisture/water vapour being produced inside the caravan.

Humid air and condensation can also be generated by things people do on a daily basis.

- Cooking: up to 3 litres per day.
- Showers: 1.5 litres per person.
- Washing dishes: up to 1 litres per day.
- Breathing: active adult 0.2 litres an hour.
- Breathing, adult asleep: 0.02 litres an hour.

### HOW TO KEEP YOUR CARAVAN DRY AND AVOID CONDENSATION

There are lots of things you can do to minimise dampness and condensation in your caravan.

The key actions:

- Provide ventilation and/or reduce relative humidity of air, particularly in moisture prone periods of year.
- When the moisture is produced in the van (cooking, shower).
- Increase heating to raise the temperature of the air and the cold surfaces.
- On dry days open windows to allow humid air to ventilate out of the van. It is better to open a few windows a little throughout the whole caravan. This helps the air to move through the caravan.
- Try to do this as often as possible (at least once a week), but keep windows closed on wet days as damp air may increase indoor humidity.

### FURNITURE

Moisture in the air can cause damage to furniture as the wood expands or contracts with an increase or decrease in the relative humidity. A relative humidity of between 40% and 60% is tolerable. If values are maintained outside this range for a sustained period damage to the furniture may occur. The damage can be visible if the relative humidity is higher than 80% for a long time. To prevent damage, ventilate the van, using dehumidifiers or water absorbent substances.

When wood is wet, wipe it dry. Do not just wait for the sun to dry it. The longer the water stays on the surface, the more damage it can do. Defects caused by high temperature or high relative humidity of air will not be covered by your warranty.



Caution should be taken when operating fixed beds without the mattress in place

## WINTERIZATION & STORAGE

The following applies whenever your caravan is stored, particularly during winter months. If you do not intend on using your vehicle for a while it is an ideal time to arrange for your caravan to have its annual service at your appointed dealer.

- It is a good idea to store the caravan with the nose down; this will avoid any water pooling on the roof.
- Do not leave your vehicle near trees or latch-type gates due to possible wind damage.
- Keep any grass around the floor of the caravan short to maintain airflow and stop any possible damp getting into it.
- It is advised that the caravan is ventilated regularly throughout the storage period, opening windows, doors and rooflights where possible.
- All moving parts should be checked for free operation.
- Clean all cooking appliances and the refrigerator before parking up the vehicle.
- Charge up the on-board battery every 2 months.
- Leave the refrigerator door open.
- Leave the furniture and locker doors open to allow air to circulate fully.
- Ensure that the entire water system is thoroughly drained.
- Make sure that all plumbing pipes, drains, and water supply appliances within the caravan are properly drained.
- Remove the battery from the caravan to keep it warmer. If the battery cells were to freeze this could cause damage to the cells and decrease the life of the battery.
- Try to cover as much as possible of the underside of the caravan to prevent snow from collecting. This will help to prevent damage to the tyres due to weather conditions.
- Apply a lubricant to all locks; this will prevent freezing.

## MODIFICATIONS & DIY WORK

Owners need to be aware that carrying out DIY modifications to your caravan may, in certain circumstances, invalidate the warranty cover and could also affect the safety and structure of the vehicle.

## CARAVAN KEYS

Each caravan is supplied with 2 identical keys. In the event of both keys being lost these cannot be replaced. In this instance a new lock will have to be fitted with a fresh set of keys.

## SPARES & AFTERSALES

There are numerous parts and accessories available for your caravan either from your Bailey retailer or through the Bailey Parts website. You are more than welcome to contact the parts website for anything you may require. However, if it is a safety or warranty-critical item you will need to obtain it from your Bailey retailer who will fit the component for you.

[www.primaleisure.com](http://www.primaleisure.com)

**FRONT BED MAKE UP**

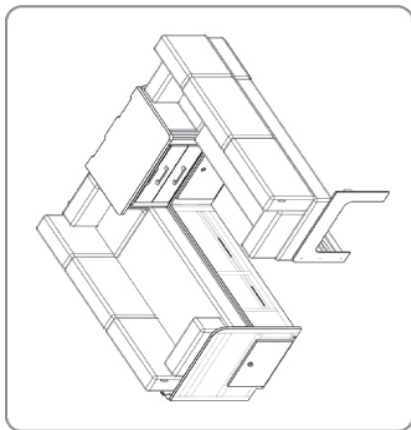

1 The lounge is shown in the day setting.

1

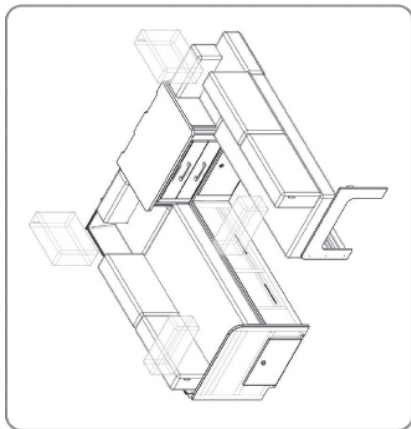

2 To change to night setting, firstly remove the four backrest cushions that are not needed.

2

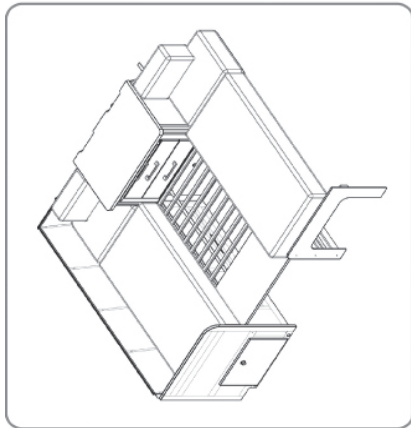

3 Pull out the leader board.

3

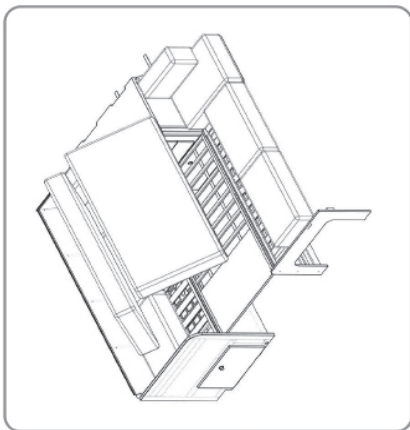

4 Place the back rests flat and press them up flush against the baffleboards.

4

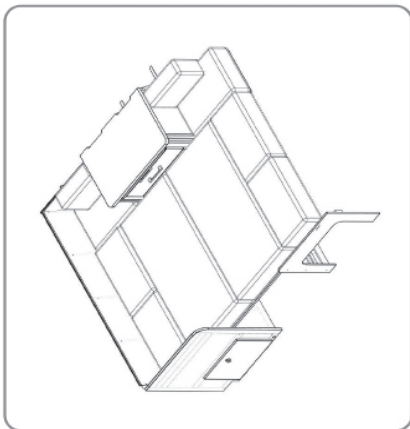

5 Turn over the seat bases and place on top of the leader board.

5

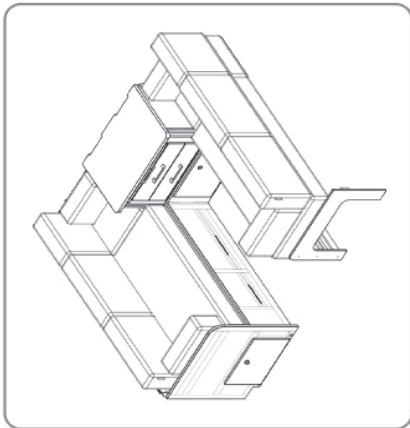

6 Reverse the process to return the lounge to its day setting.

6

## REAR DINETTE BED MAKE UP

## BED MAKE UP

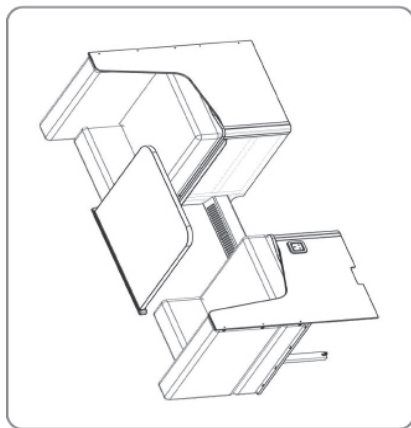

1 The Dinette is shown in the day setting.

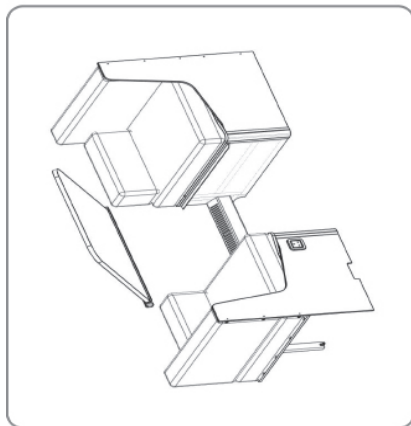

2 To change to night setting, firstly lift up the table top.

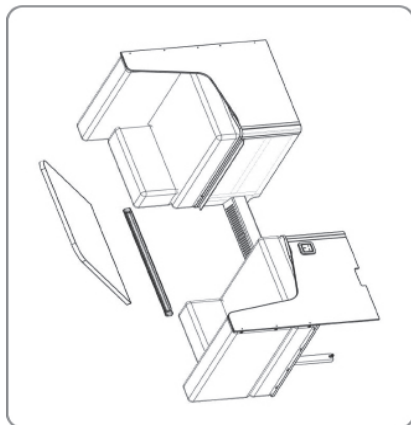

3 Remove the table top from the hinge.

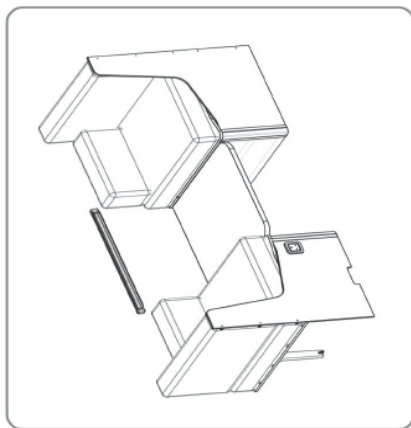

4 Place the table top on the plastic runners at the edge of the seat base.

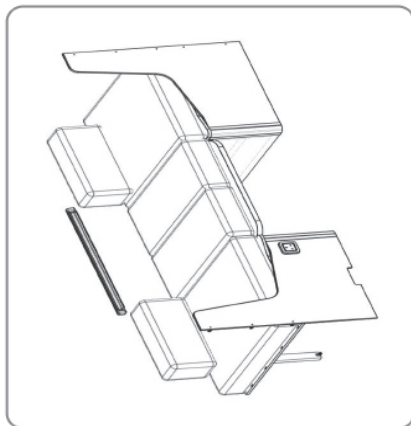

5 Place the two seat backs over the table top.

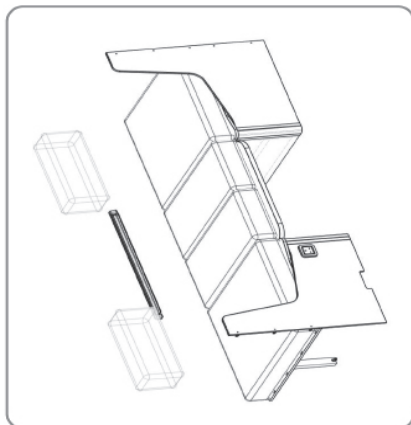

6 Remove the remaining two back rests to obtain the full width.

**GRANDE DINETTE BED MAKE UP**

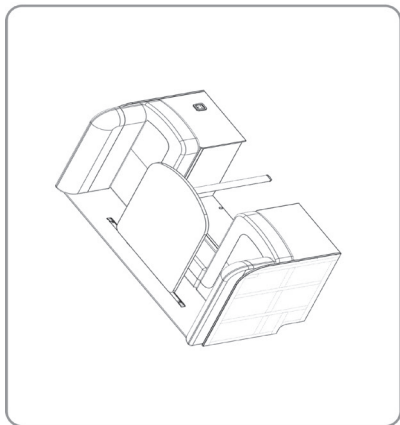

**1**

The lounge is shown in the day setting.

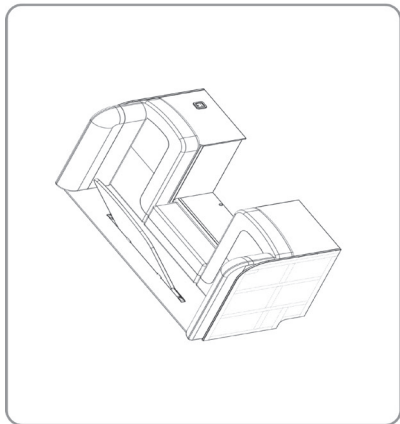

**2**

To change to night setting, firstly remove the table from the side wall and bend the leg into the storage position.

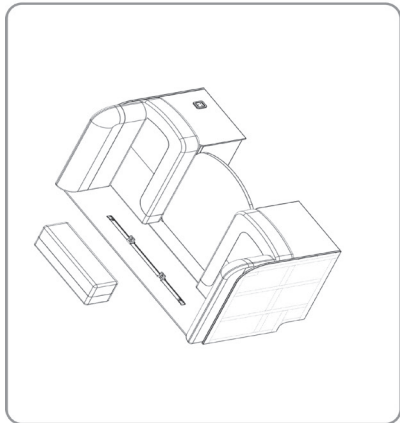

**3**

Remove and store the infill cushion and place the table flat on the plastic runners.

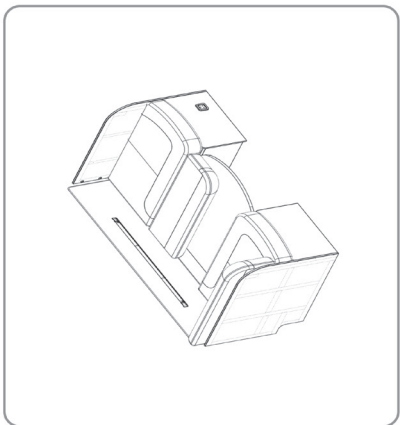

**4**

Place the back rest face down on top of the table.

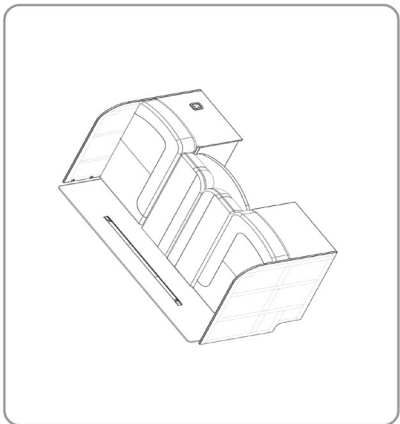

**5**

Repeat the previous process with the other back rest.

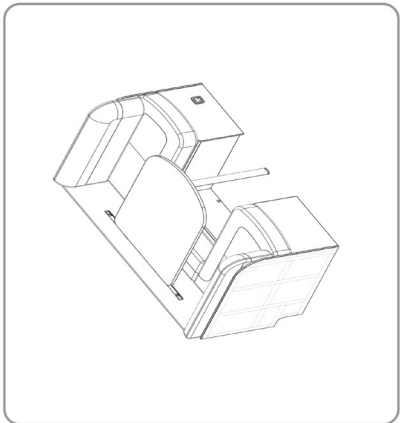

**6**

Reverse the process to return the lounge to its day setting.

## RETRACTABLE REAR BED

## ADDITIONAL FOLD OUT REAR BED

### BED MAKE UP

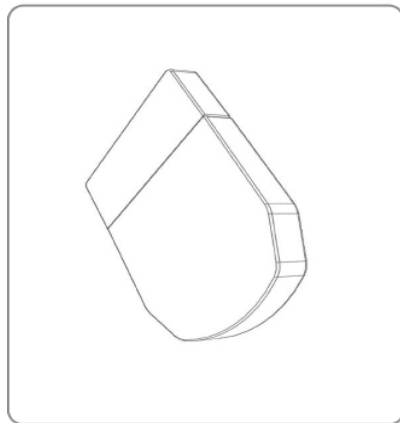

**1** The rear fixed bed in certain models is retractable.

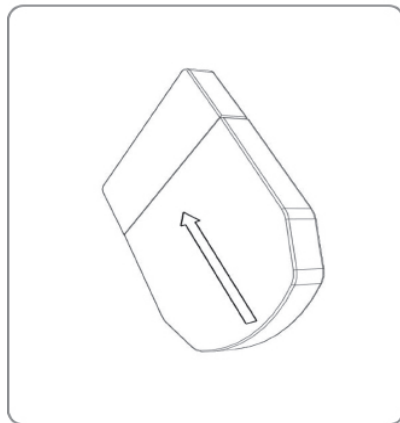

**2** To retract the bed. Kift the foot of the bed up and then push towards the head.

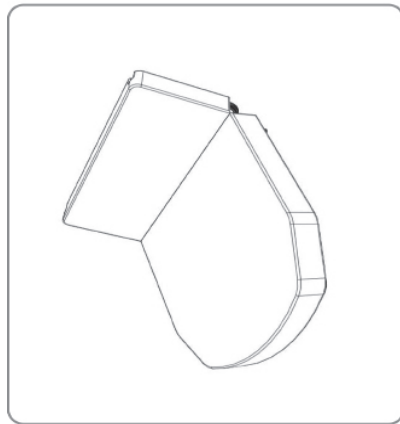

**3** The locking system below the bed frame will lock into place in various positions. Above is the retracted position.

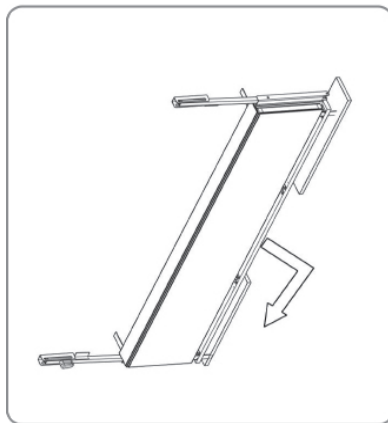

**1** The additional bunk should be pulled from the bottom away from the side wall.

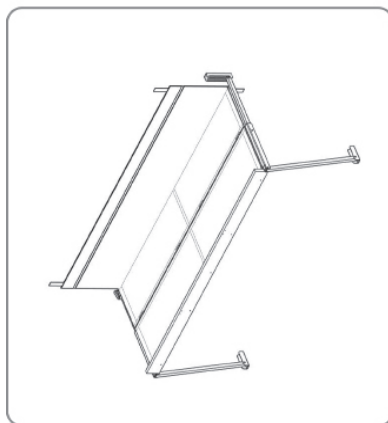

**2** The bunk will rotate and open out to form the bed. Ensure you lock the bed in position.

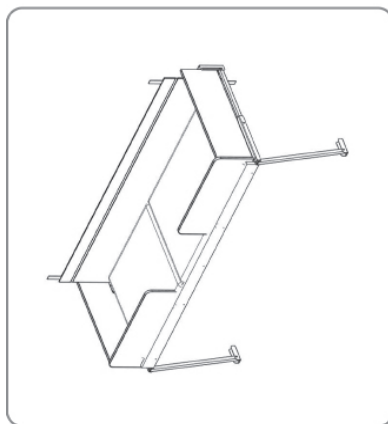

**3** Once open position the mattress/cushions and secure the fall out panels in their correct position.



FREE STANDING TABLE



Dependant upon caravan model you may have been supplied a free standing table. (Tables designs may differ slightly dependant on the age of your caravan).



1. The table should be laid upside down on a flat surface.



2. Raise the leg to its vertical position until the securing bar locks in place.



3.Repeat the process with the other leg.



Always erect the table upside down due to a finger trap hazard being present at the base of the hinge/leg (Fig 1/2). When erected the right way up the weight of the legs will cause them to fall into place. This action poses a finger trap hazard in and around the hinge.



fig .1



fig .2



# Caravan Service Manual

April 2022



ALICANTO GRANDE



PEGASUS  
GRANDE SE



UNICORN



PHOENIX<sup>+</sup>

DISCOVERY



©BAILEY OF BRISTOL 2022. ALL RIGHTS RESERVED

No part of this document may be reproduced or transmitted in any form or by any means, electronic or mechanical, for any purpose, without the express permission of Bailey of Bristol Ltd.

If the caravan is sold before the end of the original warranty the remaining period can be transferred to the new owner using the warranty transfer form. There is a fee charged for this service of £35 including VAT. Please send a copy of the Service Handbook, Proof of the purchase date along with this sheet and a copy of the service sheets from this service guide along with a cheque for £35 to Bailey of Bristol, South Liberty Lane, Bristol, BS3 2SS. Please make your cheque payable to "Bailey Caravans Ltd". We are unable to accept any other form of payment. In order for the warranty to remain valid the caravan must have been serviced annually by an authorised Bailey Service Centre prior to the transfer of ownership. Failure to do so will invalidate any further warranty cover. Failure to request this transfer within 3 months of acquisition by the new owner will invalidate the remaining warranty.

Terms and Conditions apply.

MODEL	_____
VIN NUMBER	_____
PURCHASE DATE	_____
PREVIOUS OWNER	_____
NEW OWNER	_____
NEW OWNER'S ADDRESS	_____
	_____
NEW OWNER'S TELEPHONE NUMBER	_____
NEW OWNER'S EMAIL ADDRESS	_____
I have read and understood the terms and conditions of the warranty, including the servicing requirements, as applicable to this vehicle.	
Signed:	_____
	Date: _____



If the caravan is sold before the end of the original warranty the remaining period can be transferred to the new owner using the warranty transfer form. There is a fee charged for this service of £35 including VAT.

Please send a copy of the Service Handbook, Proof of the purchase date along with this sheet and a copy of the service sheets from this service guide along with a cheque for £35 to Bailey of Bristol, South Liberty Lane, Bristol, BS3 2SS. Please make your cheque payable to "Bailey Caravans Ltd". We are unable to accept any other form of payment.

In order for the warranty to remain valid the caravan must have been serviced annually by an authorised Bailey Service Centre prior to the transfer of ownership. Failure to do so will invalidate any further warranty cover.

Failure to request this transfer within 3 months of acquisition by the new owner will invalidate the remaining warranty.

Terms and Conditions apply.

MODEL	_____
VIN NUMBER	_____
PURCHASE DATE	_____
PREVIOUS OWNER	_____
NEW OWNER	_____
NEW OWNER'S ADDRESS	_____
	_____
NEW OWNER'S TELEPHONE NUMBER	_____
NEW OWNER'S EMAIL ADDRESS	_____

I have read and understood the terms and conditions of the warranty, including the servicing requirements, as applicable to this vehicle.

Signed: \_\_\_\_\_ Date: \_\_\_\_\_



If the caravan is sold before the end of the original warranty the remaining period can be transferred to the new owner using the warranty transfer form. There is a fee charged for this service of £35 including VAT. Please send a copy of the Service Handbook, Proof of the purchase date along with this sheet and a copy of the service sheets from this service guide along with a cheque for £35 to Bailey of Bristol, South Liberty Lane, Bristol, BS3 2SS. Please make your cheque payable to "Bailey Caravans Ltd". We are unable to accept any other form of payment.

In order for the warranty to remain valid the caravan must have been serviced annually by an authorised Bailey Service Centre prior to the transfer of ownership. Failure to do so will invalidate any further warranty cover.

Failure to request this transfer within 3 months of acquisition by the new owner will invalidate the remaining warranty.

Terms and Conditions apply.

MODEL	_____
VIN NUMBER	_____
PURCHASE DATE	_____
PREVIOUS OWNER	_____
NEW OWNER	_____
NEW OWNER'S ADDRESS	_____
	_____
NEW OWNER'S TELEPHONE NUMBER	_____
NEW OWNER'S EMAIL ADDRESS	_____
<p>I have read and understood the terms and conditions of the warranty, including the servicing requirements, as applicable to this vehicle.</p>	
Signed:	_____
	_____
Date:	_____





If the caravan is sold before the end of the original warranty the remaining period can be transferred to the new owner using the warranty transfer form. There is a fee charged for this service of £35 including VAT. Please send a copy of the Service Handbook, Proof of the purchase date along with this sheet and a copy of the service sheets from this service guide along with a cheque for £35 to Bailey of Bristol, South Liberty Lane, Bristol, BS3 2SS. Please make your cheque payable to "Bailey Caravans Ltd". We are unable to accept any other form of payment. In order for the warranty to remain valid the caravan must have been serviced annually by an authorised Bailey Service Centre prior to the transfer of ownership. Failure to do so will invalidate any further warranty cover. Failure to request this transfer within 3 months of acquisition by the new owner will invalidate the remaining warranty.

Terms and Conditions apply.

MODEL	_____
VIN NUMBER	_____
PURCHASE DATE	_____
PREVIOUS OWNER	_____
NEW OWNER	_____
NEW OWNER'S ADDRESS	_____
NEW OWNER'S TELEPHONE NUMBER	_____
NEW OWNER'S EMAIL ADDRESS	_____
I have read and understood the terms and conditions of the warranty, including the servicing requirements, as applicable to this vehicle.	
Signed:	_____
Date:	_____



If the caravan is sold before the end of the original warranty the remaining period can be transferred to the new owner using the warranty transfer form. There is a fee charged for this service of £35 including VAT.

Please send a copy of the Service Handbook, Proof of the purchase date along with this sheet and a copy of the service sheets from this service guide along with a cheque for £35 to Bailey of Bristol, South Liberty Lane, Bristol, BS3 2SS. Please make your cheque payable to "Bailey Caravans Ltd". We are unable to accept any other form of payment.

In order for the warranty to remain valid the caravan must have been serviced annually by an authorised Bailey Service Centre prior to the transfer of ownership. Failure to do so will invalidate any further warranty cover.

Failure to request this transfer within 3 months of acquisition by the new owner will invalidate the remaining warranty.

Terms and Conditions apply.

MODEL	_____
VIN NUMBER	_____
PURCHASE DATE	_____
PREVIOUS OWNER	_____
NEW OWNER	_____
NEW OWNER'S ADDRESS	_____
	_____
NEW OWNER'S TELEPHONE NUMBER	_____
NEW OWNER'S EMAIL ADDRESS	_____
I have read and understood the terms and conditions of the warranty, including the servicing requirements, as applicable to this vehicle.	
Signed:	_____
	Date: _____



If the caravan is sold before the end of the original warranty the remaining period can be transferred to the new owner using the warranty transfer form. There is a fee charged for this service of £35 including VAT.

Please send a copy of the Service Handbook, Proof of the purchase date along with this sheet and a copy of the service sheets from this service guide along with a cheque for £35 to Bailey of Bristol, South Liberty Lane, Bristol, BS3 2SS. Please make your cheque payable to "Bailey Caravans Ltd". We are unable to accept any other form of payment.

In order for the warranty to remain valid the caravan must have been serviced annually by an authorised Bailey Service Centre prior to the transfer of ownership. Failure to do so will invalidate any further warranty cover.

Failure to request this transfer within 3 months of acquisition by the new owner will invalidate the remaining warranty.

Terms and Conditions apply.

MODEL	_____
VIN NUMBER	_____
PURCHASE DATE	_____
PREVIOUS OWNER	_____
NEW OWNER	_____
NEW OWNER'S ADDRESS	_____
	_____
NEW OWNER'S TELEPHONE NUMBER	_____
NEW OWNER'S EMAIL ADDRESS	_____
I have read and understood the terms and conditions of the warranty, including the servicing requirements, as applicable to this vehicle.	
Signed:	_____
	Date: _____



If the caravan is sold before the end of the original warranty the remaining period can be transferred to the new owner using the warranty transfer form. There is a fee charged for this service of £35 including VAT. Please send a copy of the Service Handbook, Proof of the purchase date along with this sheet and a copy of the service sheets from this service guide along with a cheque for £35 to Bailey of Bristol, South Liberty Lane, Bristol, BS3 2SS. Please make your cheque payable to "Bailey Caravans Ltd". We are unable to accept any other form of payment.

In order for the warranty to remain valid the caravan must have been serviced annually by an authorised Bailey Service Centre prior to the transfer of ownership. Failure to do so will invalidate any further warranty cover.

Failure to request this transfer within 3 months of acquisition by the new owner will invalidate the remaining warranty.

Terms and Conditions apply.

MODEL	_____
VIN NUMBER	_____
PURCHASE DATE	_____
PREVIOUS OWNER	_____
NEW OWNER	_____
NEW OWNER'S ADDRESS	_____
	_____
NEW OWNER'S TELEPHONE NUMBER	_____
NEW OWNER'S EMAIL ADDRESS	_____

I have read and understood the terms and conditions of the warranty, including the servicing requirements, as applicable to this vehicle.

Signed: \_\_\_\_\_ Date: \_\_\_\_\_





If the caravan is sold before the end of the original warranty the remaining period can be transferred to the new owner using the warranty transfer form. There is a fee charged for this service of £35 including VAT. Please send a copy of the Service Handbook, Proof of the purchase date along with this sheet and a copy of the service sheets from this service guide along with a cheque for £35 to Bailey of Bristol, South Liberty Lane, Bristol, BS3 2SS. Please make your cheque payable to "Bailey Caravans Ltd". We are unable to accept any other form of payment. In order for the warranty to remain valid the caravan must have been serviced annually by an authorised Bailey Service Centre prior to the transfer of ownership. Failure to do so will invalidate any further warranty cover. Failure to request this transfer within 3 months of acquisition by the new owner will invalidate the remaining warranty.

Terms and Conditions apply.

MODEL	_____
VIN NUMBER	_____
PURCHASE DATE	_____
PREVIOUS OWNER	_____
NEW OWNER	_____
NEW OWNER'S ADDRESS	_____
	_____
NEW OWNER'S TELEPHONE NUMBER	_____
NEW OWNER'S EMAIL ADDRESS	_____
I have read and understood the terms and conditions of the warranty, including the servicing requirements, as applicable to this vehicle.	
Signed:	_____
	Date: _____



If the caravan is sold before the end of the original warranty the remaining period can be transferred to the new owner using the warranty transfer form. There is a fee charged for this service of £35 including VAT. Please send a copy of the Service Handbook, Proof of the purchase date along with this sheet and a copy of the service sheets from this service guide along with a cheque for £35 to Bailey of Bristol, South Liberty Lane, Bristol, BS3 2SS. Please make your cheque payable to "Bailey Caravans Ltd". We are unable to accept any other form of payment. In order for the warranty to remain valid the caravan must have been serviced annually by an authorised Bailey Service Centre prior to the transfer of ownership. Failure to do so will invalidate any further warranty cover. Failure to request this transfer within 3 months of acquisition by the new owner will invalidate the remaining warranty.

Terms and Conditions apply.

MODEL	_____
VIN NUMBER	_____
PURCHASE DATE	_____
PREVIOUS OWNER	_____
NEW OWNER	_____
NEW OWNER'S ADDRESS	_____
	_____
NEW OWNER'S TELEPHONE NUMBER	_____
NEW OWNER'S EMAIL ADDRESS	_____
I have read and understood the terms and conditions of the warranty, including the servicing requirements, as applicable to this vehicle.	
Signed:	_____
	Date: _____



If the caravan is sold before the end of the original warranty the remaining period can be transferred to the new owner using the warranty transfer form. There is a fee charged for this service of £35 including VAT.

Please send a copy of the Service Handbook, Proof of the purchase date along with this sheet and a copy of the service sheets from this service guide along with a cheque for £35 to Bailey of Bristol, South Liberty Lane, Bristol, BS3 2SS. Please make your cheque payable to "Bailey Caravans Ltd". We are unable to accept any other form of payment.

In order for the warranty to remain valid the caravan must have been serviced annually by an authorised Bailey Service Centre prior to the transfer of ownership. Failure to do so will invalidate any further warranty cover.

Failure to request this transfer within 3 months of acquisition by the new owner will invalidate the remaining warranty.

Terms and Conditions apply.

MODEL	_____
VIN NUMBER	_____
PURCHASE DATE	_____
PREVIOUS OWNER	_____
NEW OWNER	_____
NEW OWNER'S ADDRESS	_____
	_____
NEW OWNER'S TELEPHONE NUMBER	_____
NEW OWNER'S EMAIL ADDRESS	_____
I have read and understood the terms and conditions of the warranty, including the servicing requirements, as applicable to this vehicle.	
Signed:	_____
	_____ Date: _____



If the caravan is sold before the end of the original warranty the remaining period can be transferred to the new owner using the warranty transfer form. There is a fee charged for this service of £35 including VAT. Please send a copy of the Service Handbook, Proof of the purchase date along with this sheet and a copy of the service sheets from this service guide along with a cheque for £35 to Bailey of Bristol, South Liberty Lane, Bristol, BS3 2SS. Please make your cheque payable to "Bailey Caravans Ltd". We are unable to accept any other form of payment.

In order for the warranty to remain valid the caravan must have been serviced annually by an authorised Bailey Service Centre prior to the transfer of ownership. Failure to do so will invalidate any further warranty cover.

Failure to request this transfer within 3 months of acquisition by the new owner will invalidate the remaining warranty.

Terms and Conditions apply.

MODEL	_____
VIN NUMBER	_____
PURCHASE DATE	_____
PREVIOUS OWNER	_____
NEW OWNER	_____
NEW OWNER'S ADDRESS	_____
	_____
NEW OWNER'S TELEPHONE NUMBER	_____
NEW OWNER'S EMAIL ADDRESS	_____
I have read and understood the terms and conditions of the warranty, including the servicing requirements, as applicable to this vehicle.	
Signed:	_____
	Date: _____







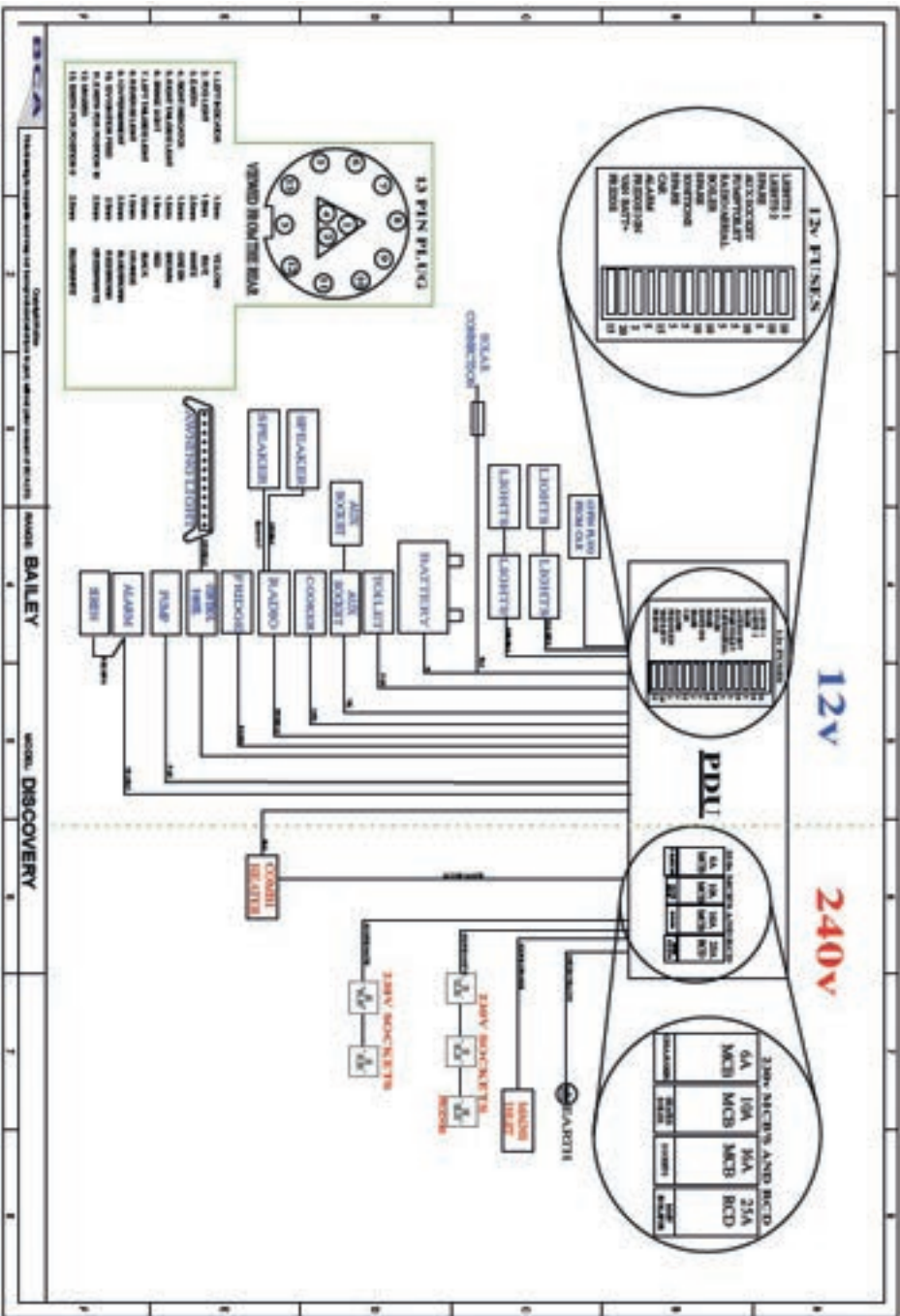

Discovery Electrical System



# PDU-RELAYS

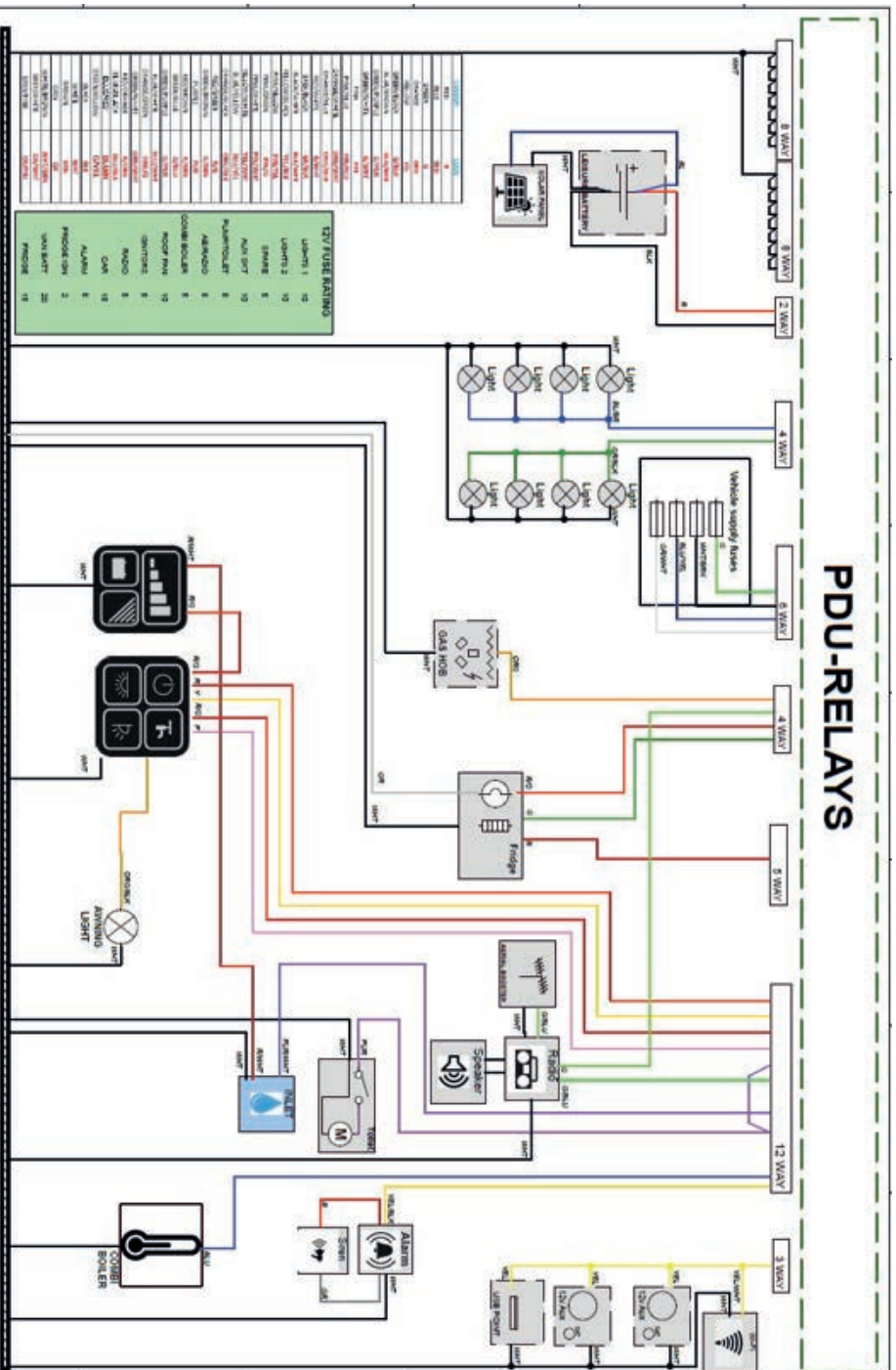

Unicorn Single Axle Electrical System

# PDU-RELAYS

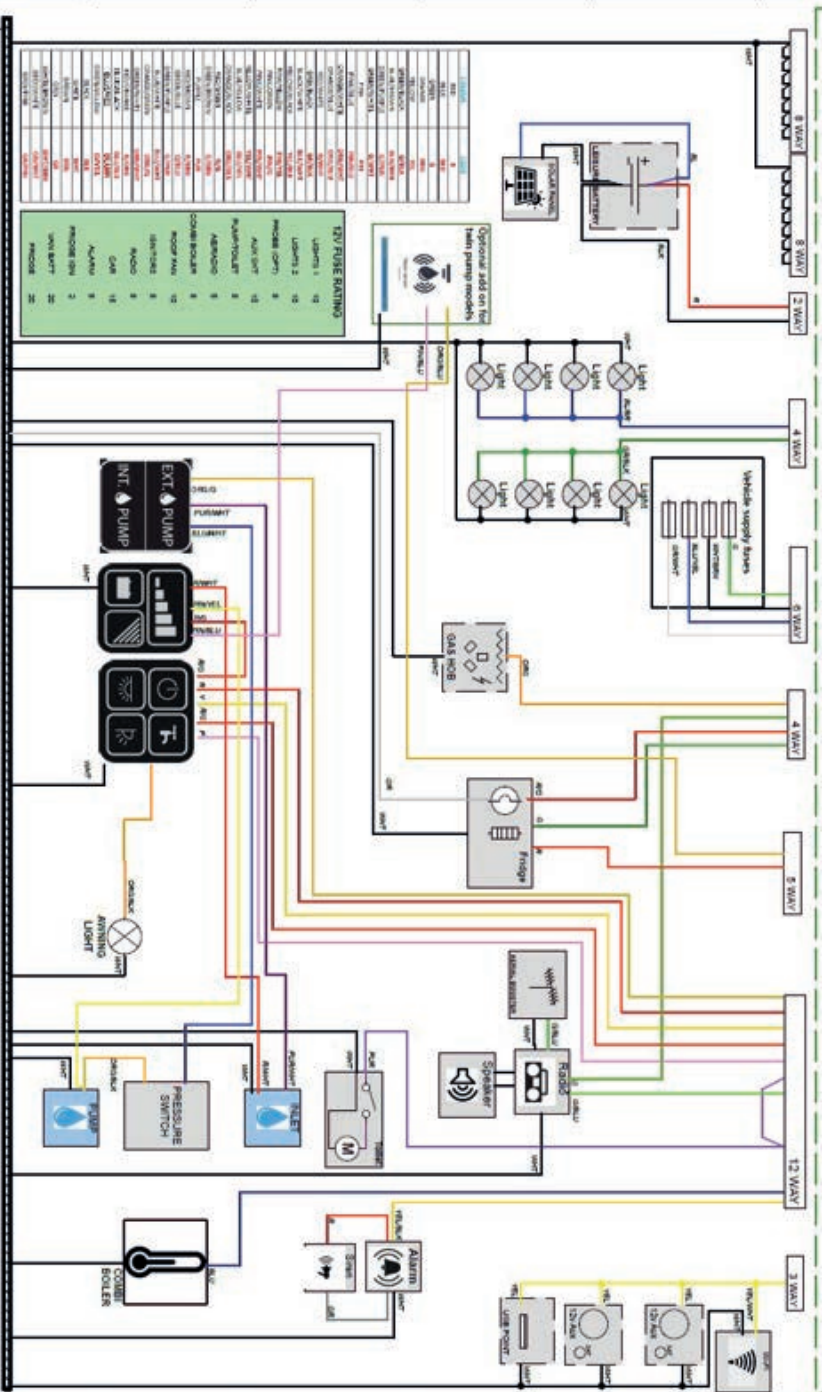

Unicorn Twin Axle Electrical System



# PDU-RELAYS

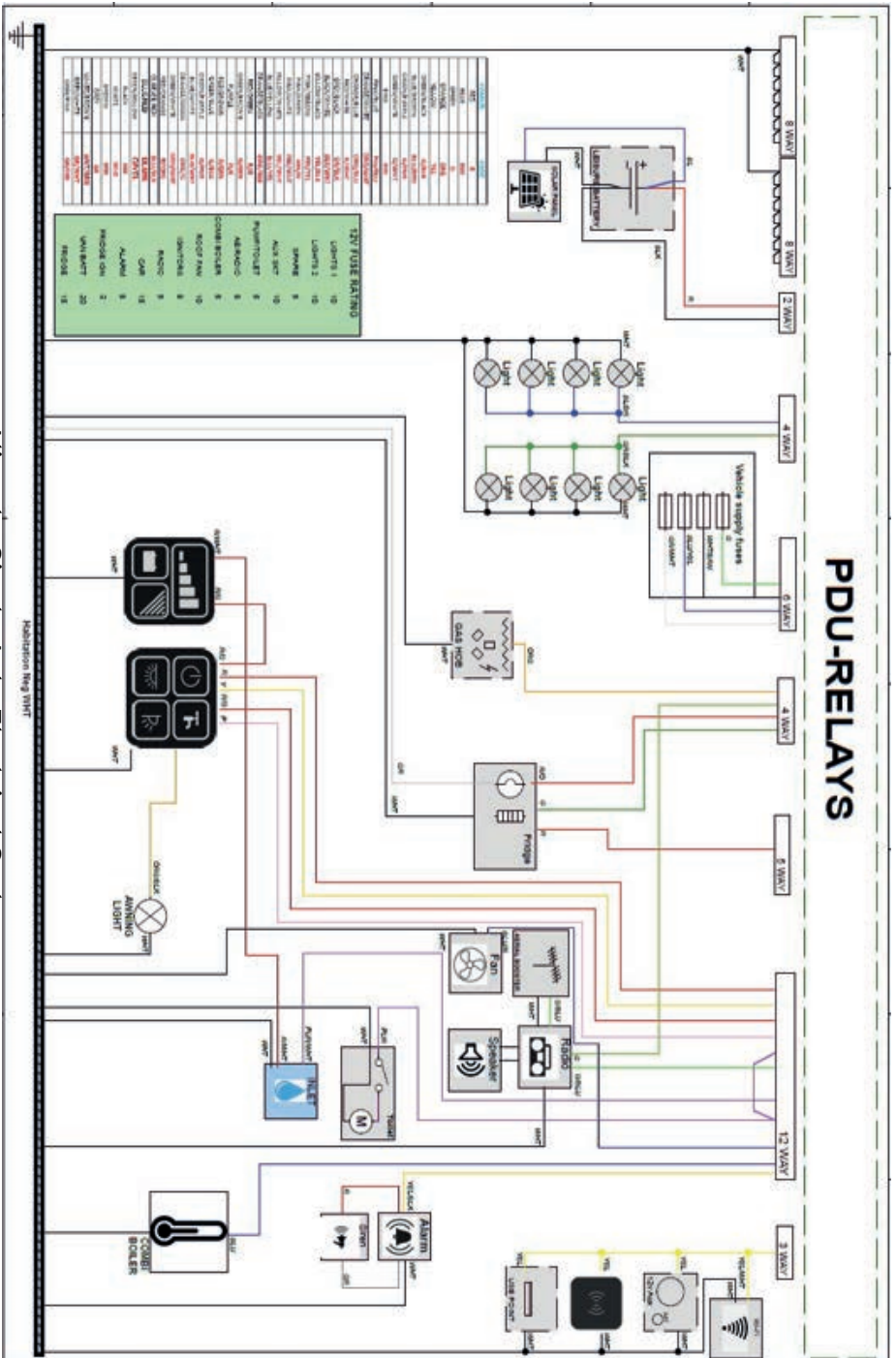

NO.	DESCRIPTION	AMPERE	CURRENT	VOLTS	WATT
1	IGNITION	15	15A	12V	180W
2	IGNITION	15	15A	12V	180W
3	IGNITION	15	15A	12V	180W
4	IGNITION	15	15A	12V	180W
5	IGNITION	15	15A	12V	180W
6	IGNITION	15	15A	12V	180W
7	IGNITION	15	15A	12V	180W
8	IGNITION	15	15A	12V	180W
9	IGNITION	15	15A	12V	180W
10	IGNITION	15	15A	12V	180W
11	IGNITION	15	15A	12V	180W
12	IGNITION	15	15A	12V	180W
13	IGNITION	15	15A	12V	180W
14	IGNITION	15	15A	12V	180W
15	IGNITION	15	15A	12V	180W
16	IGNITION	15	15A	12V	180W
17	IGNITION	15	15A	12V	180W
18	IGNITION	15	15A	12V	180W
19	IGNITION	15	15A	12V	180W
20	IGNITION	15	15A	12V	180W
21	IGNITION	15	15A	12V	180W
22	IGNITION	15	15A	12V	180W
23	IGNITION	15	15A	12V	180W
24	IGNITION	15	15A	12V	180W
25	IGNITION	15	15A	12V	180W
26	IGNITION	15	15A	12V	180W
27	IGNITION	15	15A	12V	180W
28	IGNITION	15	15A	12V	180W
29	IGNITION	15	15A	12V	180W
30	IGNITION	15	15A	12V	180W
31	IGNITION	15	15A	12V	180W
32	IGNITION	15	15A	12V	180W
33	IGNITION	15	15A	12V	180W
34	IGNITION	15	15A	12V	180W
35	IGNITION	15	15A	12V	180W
36	IGNITION	15	15A	12V	180W
37	IGNITION	15	15A	12V	180W
38	IGNITION	15	15A	12V	180W
39	IGNITION	15	15A	12V	180W
40	IGNITION	15	15A	12V	180W
41	IGNITION	15	15A	12V	180W
42	IGNITION	15	15A	12V	180W
43	IGNITION	15	15A	12V	180W
44	IGNITION	15	15A	12V	180W
45	IGNITION	15	15A	12V	180W
46	IGNITION	15	15A	12V	180W
47	IGNITION	15	15A	12V	180W
48	IGNITION	15	15A	12V	180W
49	IGNITION	15	15A	12V	180W
50	IGNITION	15	15A	12V	180W
51	IGNITION	15	15A	12V	180W
52	IGNITION	15	15A	12V	180W
53	IGNITION	15	15A	12V	180W
54	IGNITION	15	15A	12V	180W
55	IGNITION	15	15A	12V	180W
56	IGNITION	15	15A	12V	180W
57	IGNITION	15	15A	12V	180W
58	IGNITION	15	15A	12V	180W
59	IGNITION	15	15A	12V	180W
60	IGNITION	15	15A	12V	180W

- FUSE BOARD**
- LIGHTS 1 - 15
  - LIGHTS 2 - 15
  - BRAKE - 15
  - AUX SECT - 15
  - IGNITION 1 - 15
  - IGNITION 2 - 15
  - IGNITION 3 - 15
  - IGNITION 4 - 15
  - IGNITION 5 - 15
  - IGNITION 6 - 15
  - IGNITION 7 - 15
  - IGNITION 8 - 15
  - IGNITION 9 - 15
  - IGNITION 10 - 15
  - IGNITION 11 - 15
  - IGNITION 12 - 15
  - IGNITION 13 - 15
  - IGNITION 14 - 15
  - IGNITION 15 - 15

Alicanto Single Axle Electrical System

Installation Ring 13477

# PDU-RELAYS

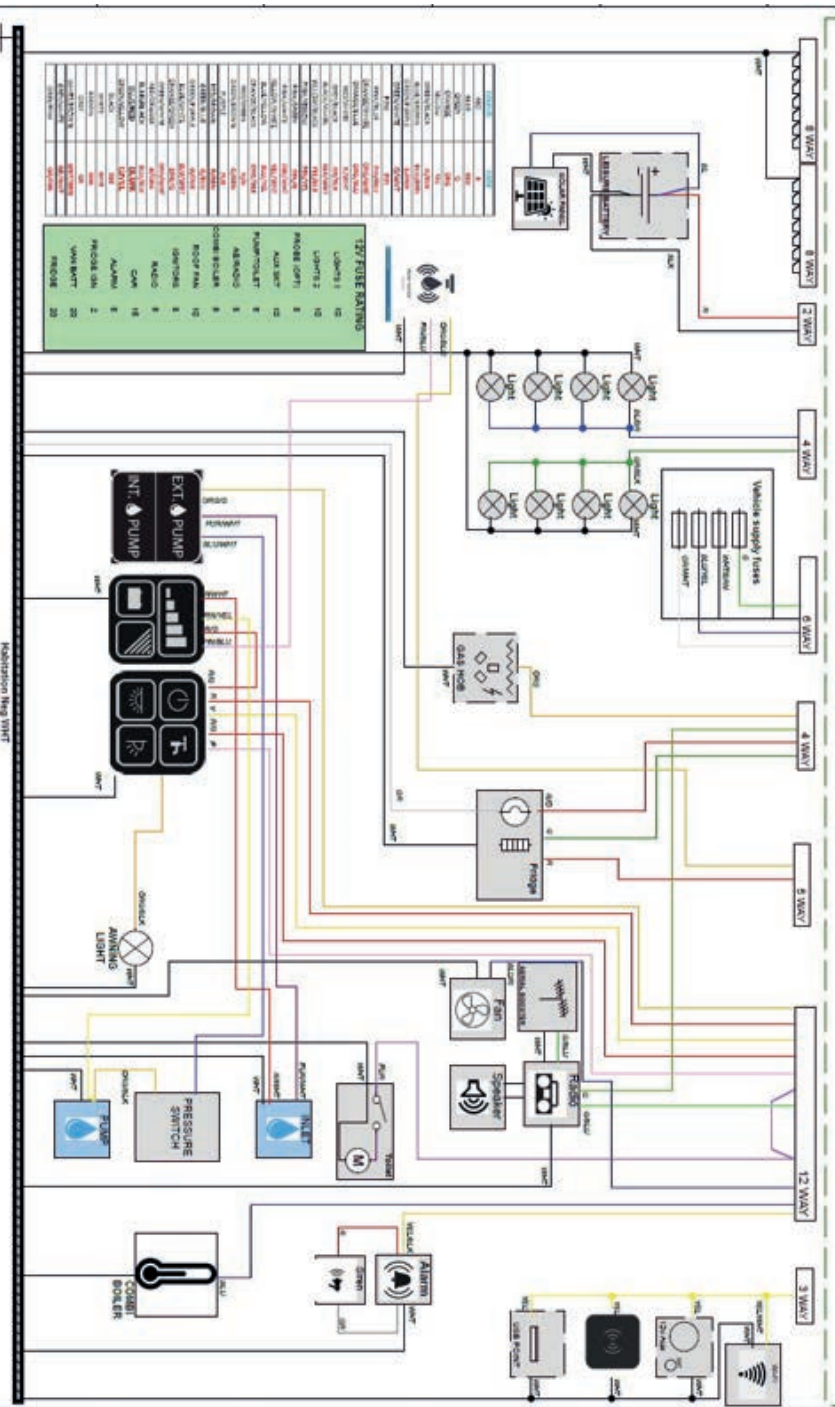

Alicanto Twin Axle Electrical System

Installation: Ring 31117

# ROAD LIGHTS

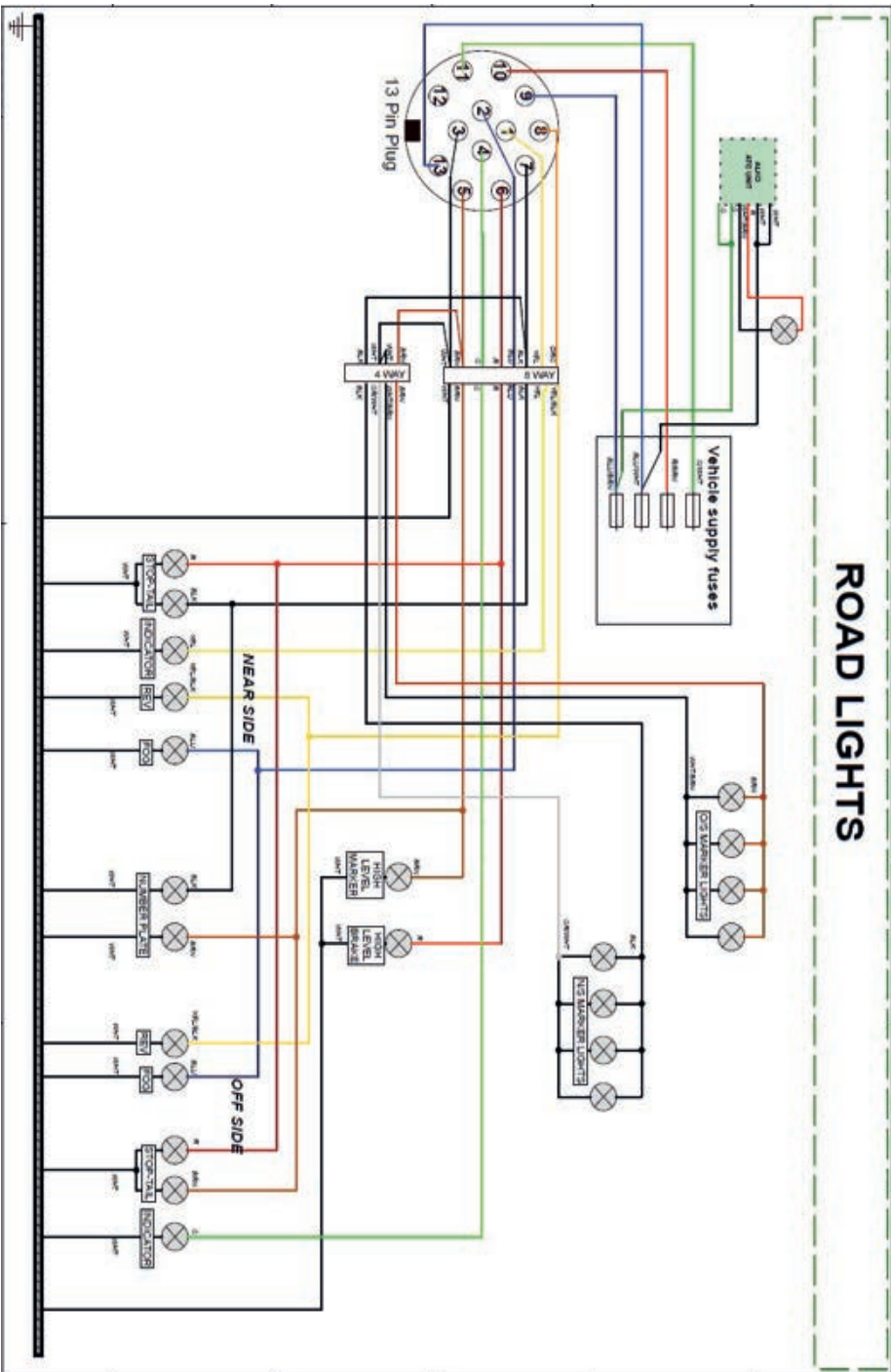

Road Light System



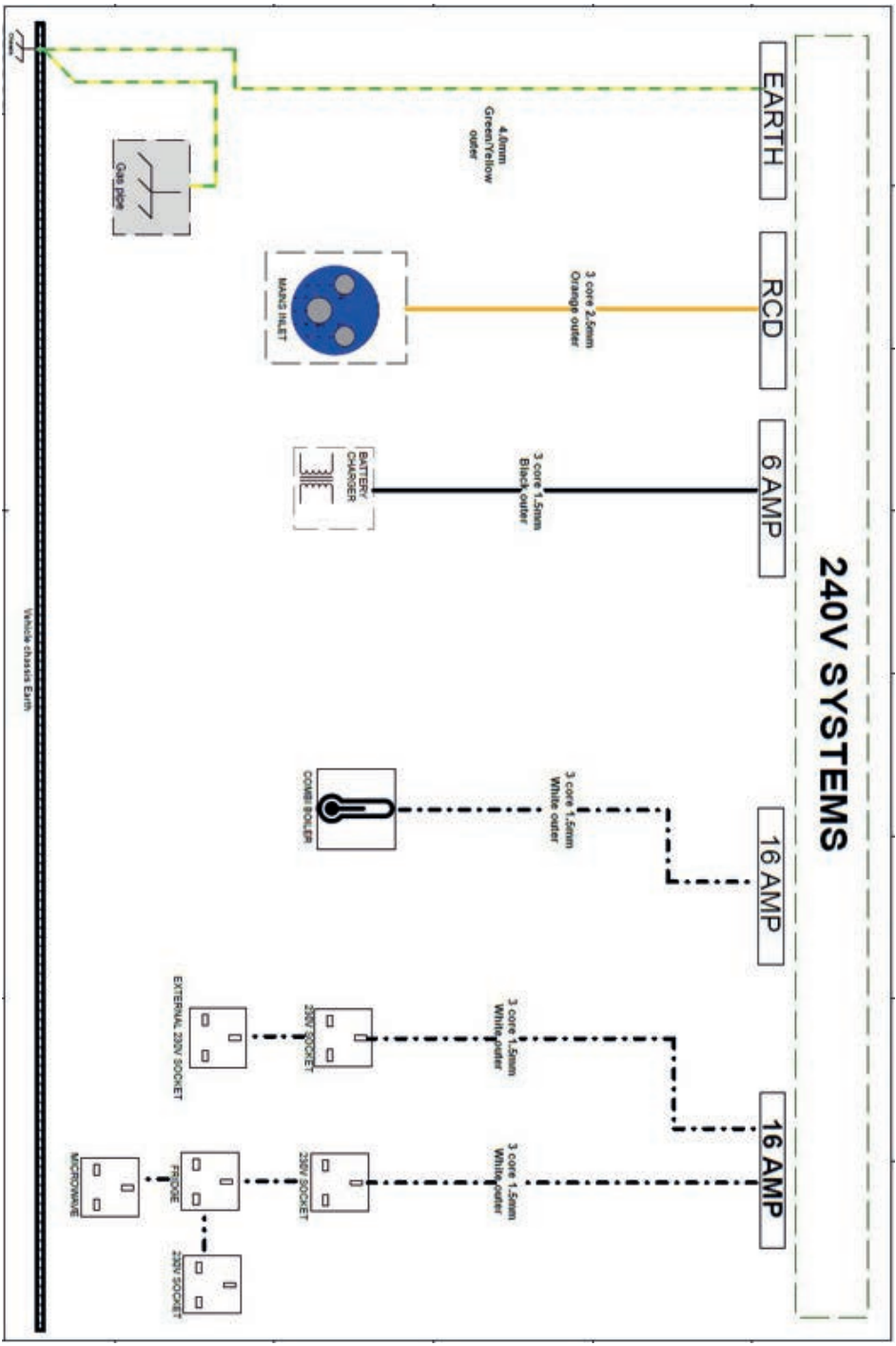

Unicorn and Alicanto 240 Volt System

Fuse MCB Specification Chart

CIRCUIT	FUSE RATING
LIGHTS 1	10A
LIGHTS 2	10A
AUX SOCKET	10A
PUMP	5A
RADIO/AERIAL	5A
BOILER	5A
ROOF FAN	5A
IGNITIONS	5A
SPARE	5A
CAR	15A
ALARM	5A
FRIDGE IGN	5A
VAN BATTERY +	20A
FRIDGE	20A

### Service Schedule

In order to validate the factory backed warranty package, your caravan must be serviced by an approved Bailey Service centre every 12 months (or within 6 weeks of each anniversary of purchase) in accordance with the NCC recommended service schedule.

A full listing of the current Approved Bailey Centres can be found on the Retailer Network pages of our website [www.bailey-caravans.co.uk](http://www.bailey-caravans.co.uk).

In no circumstances should the body shell fixings be tampered with or adjusted by the caravan owner. In instances where this has occurred the warranty will be automatically invalidated.

Standard Moisture survey for Alu-tech construction caravans

A moisture survey must be carried out using a calibrated moisture meter every 12 months by an Approved Bailey Service Centre.

Readings should be taken on the floor section of the vehicle in positions where the holes created by the meter's probes are not visible i.e. behind seals, in bed boxes or in cupboard bases. It is important to make sure that the probes are free from moisture and the surface of the floor is free from condensation.

Readings below 20% are considered acceptable. Readings greater than 20% will identify areas that need further investigation and possible remedial work. All other parts of the Alu-Tech caravan should be checked visually for moisture ingress.

### Thermal Insulation Grade

All Alu-Tech Bailey Caravans are manufactured and approved by the NCC to EN1645 thermal grade III. This has been approved using the caravan heating system on both electric and gas.

Grade III is classified as being able to achieve an average temperature difference of 35°C between inside the caravan and outside when the exterior temperature is 15°C.

### Weight Plates

Please note there are two different weight plates on your caravan. One in the gas locker and one to the side of your habitation door.

The Gas locker plate is for EWVTA purposes and shows the following:

Manufacturer  
Type Approval Number  
VIN Number  
MTPLM

0 - MTPLM NOSE WEIGHT  
1 - MTPLM AXLE 1 WEIGHT  
2 - MTPLM AXLE 2 WEIGHT

**BAILEY CARAVANS**  
 61372007/46\*1206  
 SGBSE6BYHP103183  
 1150 kg  
 0 - 100 kg  
 1 - 1150 kg  
 2 - N/A

The habitation door plate is for NCC purposes and should be referenced by the customer for caravans weights. The MTPLM and MRO on this plate should be observed and adhered to by the customer when loading or towing the caravan. Any values shown should not be exceeded without express permission from the manufacturer.





Pegasus Grande	Messina	Bologna	Rimini	Brindisi	Palermo	Turin	Ancona
Front Double	7'3" x 4'3"	7'3" x 4'3"	7'3" x 4'0"	7'3" x 4'0"	7'1" x 4'9"	7'1" x 4'9"	7'3" x 4'9"
Front nearside Single	6'2" x 2'1"	6'2" x 2'1"	N/A	N/A	N/A	N/A	6'2" x 2'1"
Front Offside Single	5'10" x 2'1"	5'10" x 2'1"	5'8" x 2'1"	5'8" x 2'1"	6'2" x 2'1"	6'2" x 2'1"	6'2" x 2'1"
Fixed Bed	6'1" x 4'7"	6'3" x 4'7"	N/A	6'3" x 4'7"	N/A	6'1" x 4'6"	5'11" x 5'2"
Rear Offside Single	N/A	N/A	6'2" x 2'6"	N/A	N/A	N/A	N/A
Rear Nearside Single	N/A	N/A	6'2" x 2'6"	N/A	6'1" x 2'6"	N/A	N/A
Middle Dinette	N/A	N/A	N/A	N/A	6'6" x 3'8"	6'6" x 3'8"	N/A
Rear Upper Bunk	N/A	N/A	N/A	N/A	6'1" x 2'6"	N/A	5'10" x 1'11"

Phoenix	420	440	640	642	644	650
Front Double	6'2" x 4'9"	6'2" x 3'7"	6'2" x 4'7"	6'2" x 4'7"	6'2" x 4'7"	6'2" x 4'7"
Front nearside Single	6'1" x 2'1"	4'11" x 2'1"	5'11" x 2'1"	5'11" x 2'1"	5'11" x 2'1"	5'11" x 2'1"
Front Offside Single	6'1" x 2'1"	4'11" x 2'1"	5'11" x 2'1"	5'11" x 2'1"	5'11" x 2'1"	5'11" x 2'1"
Rear Fixed Bed	N/A	6'3" x 4'4"	6'2" x 4'6"	N/A	6'2" x 4'6"	N/A
Rear Offside Single	N/A	N/A	N/A	6'2" x 2'2"	N/A	N/A
Rear Nearside Single	N/A	N/A	N/A	6'2" x 2'2"	N/A	6'2" x 2'3"
Upper Rear Bunk	N/A	N/A	N/A	N/A	N/A	6'1" x 2'2"

## BED SIZES

Discovery	D4-2	D4-3	D4-4
Front Double	6'2" x 5'8"	6'2" x 3	6'2" x 4'6"
Front nearside Single	6'7" x 2'1"	3'11" x 2'1"	5'5" x 2'1"
Front Offside Single	6'7" x 2'1"	4'10" x 2'1"	5'5" x 2'1"
Rear Fixed Bed	N/A	6'6" x 4'	6'1" x 4'4"
Rear Offside Single	N/A	N/A	N/A
Rear Nearside Single	N/A	N/A	N/A
Upper Rear Bunk	N/A	N/A	N/A
Lower Bunk	N/A	N/A	N/A

Discovery	D4-2	D4-3	D4-4
Berths	2	3	4
Axes	1	1	1
Shipping Length	5615mm	6112mm	7141mm
Internal Length	3866mm	4354mm	5398mm
Overall Width	2228mm	2228mm	2228mm
Overall Height (including aerial)	2605mm	2605mm	2605mm
Maximum Headroom	1960mm	1960mm	1960mm
Body Length (excluding hitch)	4119mm	4620mm	5649mm
Tyre Sizes	185R14C	185R14C	185R14C
Awning Dimension	10041mm	10558mm	11557mm
Tyre Pressure	55psi	55psi	55psi
MRO	884kg	946kg	1059kg
MTPLM	995kg	1082kg	1206kg
Opt Equipment Payload	0	0	0
Total User Payload	111kg	116kg	146kg
Max Static Load on the Coupling Head	100kg	100kg	100kg
Wheel Bolt Torque	130N	130N	130N
Gas Locker Capacity	6kg x2	6kg x2	6kg x2

BED SIZES

Alicanto Grande II	Porto	Lisbon	Evora
Front Double	7` x 4`	7` x 3` 9"	7` x 4`
Front nearside Single	6` x 2` 1"	5` 9" x 2` 1"	6` x 2` 1"
Front Offside Single	6` x 2` 1"	5` 8" x 2` 1"	6` x 2` 1"
Rear Fixed Bed	6` 3" x 5`	6` 3" x 5`	6` 3" x 5`

Unicorn V	Seville	Madrid	Vigo	Cadiz	Cabrera	Cartagena	Pamplona
Front Double	6` 4" x 4` 11"	6` 4" x 5`	6` 4" x 4` 3"	6` 4" x 4` 3"	6` 4" x 4` 3"	6` 4" x 4` 10"	6` 4" x 4` 10"
Front N/S Single	6` 5" x 2`	6` 5" x 2`	5` 9" x 2`	5` 9" x 2`	5` 9" x 2`	5` 9" x 2`	6` 5" x 2`
Front O/S Single	6` 5" x 2`	6` 5" x 2`	5` 9" x 2`	5` 9" x 2`	5` 9" x 2`	5` 9" x 2`	6` 5" x 2`
Rear Fixed Bed	N/A	N/A	6` 5" x 4` 8"	N/A	6` 5" x 4` 8"	6` 5" x 4` 8"	6` 5" x 4` 8"
Rear O/S Single	N/A	6` x 2` 1"	N/A	6` 4" x 2` 4"	N/A	N/A	N/A
Rear N/S Single	N/A	N/A	N/A	6` 4" x 2` 4"	N/A	N/A	N/A
Side Dinette Bunk	N/A	5` 10" x 1` 11"	N/A	N/A	N/A	N/A	N/A

Pegasus Grande SE	Messina	Bologna	Rimini	Brindisi	Palermo	Turin	Ancona
Berths	4	4	4	4	6	6	5
Axles	2	2	1	1	2	2	1
Shipping Length	7863mm	7863mm	7381mm	7381mm	7863mm	7863mm	7381mm
Internal Length	6334mm	6334mm	5904mm	5904mm	6334mm	6334mm	5904mm
Overall Width	2450mm	2450mm	2450mm	2450mm	2450mm	2450mm	2450mm
Overall Height (including aerial)	2583mm	2583mm	2608mm	2608mm	2583mm	2583mm	2608mm
Maximum Headroom	1960mm	1960mm	1960mm	1960mm	1960mm	1960mm	1960mm
Body Length (excluding hitch)	6989mm	6989mm	6496mm	6496mm	6989mm	6989mm	6496mm
Tyre Sizes	185/65R14	185/65R14	195/70R15C	195/70R15C	185/65R14	185/65R14	195/70R15C
Awing Dimension	10772mm	10772mm	10332mm	10332mm	10772mm	10772mm	10332mm
Tyre Pressure	40psi	40psi	60psi	60psi	40psi	40psi	60psi
MRO	1538kg	1496kg	1401kg	1384kg	1535kg	1544kg	1435kg
MTPLM	1698kg	1656kg	1556kg	1539kg	1715kg	1724kg	1600kg
Opt Equipment Payload	0kg	0kg	0kg	0kg	0kg	0kg	0kg
Total User Payload	160kg	160kg	155kg	155kg	180kg	180kg	165kg
Max Static Load on the Coupling Head	120kg	120kg	100kg	100kg	120kg	120kg	100kg
Wheel Bolt Torque	130nm	130nm	130nm	130nm	130nm	130nm	130nm
Gas Locker Capacity	2x6kg	2x6kg	2x6kg	2x6kg	2x6kg	2x6kg	2x6kg



Phoenix +	420	440	640	642	644	650
Berths	2	4	4	4	4	5
Axles	1	1	1	1	1	1
Shipping Length	5564mm	6883mm	7370mm	7370mm	7370mm	7370mm
Internal Length	4032mm	5351mm	5841mm	5841mm	5841mm	5841mm
Overall Width	2212mm	2212mm	2212mm	2212mm	2212mm	2212mm
Overall Height (including aerial)	2624mm	2624mm	2624mm	2624mm	2624mm	2624mm
Maximum Headroom	1960mm	1960mm	1960mm	1960mm	1960mm	1960mm
Body Length (excluding hitch)	4694mm	6033mm	6499mm	6499mm	6499mm	6499mm
Tyre Sizes	185R14C	185R14C	185R14C	185R14C	185R14C	185R14C
Awning Dimension	8571mm	9959mm	10350mm	10350mm	10350mm	10350mm
Tyre Pressure	48psi	60psi	60psi	60psi	60psi	60psi
MRO	1029kg	1197kg	1257kg	1255kg	1240kg	1244kg
MTPLM	1146kg	1347kg	1411kg	1410kg	1395kg	1409kg
Opt Equipment Payload	0	0	0	0	0	0
Total User Payload	117kg	150kg	155kg	155kg	155kg	165kg
Max Static Load on the Coupling Head	100kg	100kg	100kg	100kg	100kg	100kg
Wheel Bolt Torque	130N	130N	130N	130N	130N	130N
Gas Locker Capacity	6kg x2	6kg x2	6kg x2	6kg x2	6kg x2	6kg x2

Alicanto Grande II	Porto	Lisbon
Berths	4	4
Axles	2	1
Shipping Length	7902mm	7363mm
Internal Length	6603mm	6066mm
Overall Width	2454mm	2454mm
Overall Height (including aerial)	2582mm	2582mm
Maximum Headroom	1959mm	1959mm
Body Length (excluding hitch)	6960mm	6418mm
Tyre Sizes	185/65R14	195/70R15
Awning Dimension	10781mm	10444mm
Tyre Pressure	40psi	60psi
MRO	1687kg	1546kg
MTPLM	1847kg	1700kg
Opt Equipment Payload	0kg	0kg
Total User Payload	160kg	154kg
Max Static Load on the Coupling Head	120kg	120kg
Wheel Torque	130N	130N
Gas Locker	6kg x2	6kg x2

Unicorn V	Seville	Madrid	Vigo	Cadiz	Cabrera	Cartagena	Pamplona
Berths	2	4	4	4	4	4	4
Axles	1	1	1	1	1	2	2
Shipping Length	6474mm	6881mm	7340mm	7340mm	7340mm	7815mm	7815mm
Internal Length	5214mm	5667mm	6067mm	6067mm	6067mm	6379mm	6379mm
Overall Width	2264mm	2264mm	2264mm	2264mm	2264mm	2264mm	2264mm
Overall Height (including aerial)	2611mm	2669mm	2611mm	2611mm	2611mm	2589mm	2589mm
Maximum Headroom	1960mm	1960mm	1960mm	1960mm	1960mm	1960mm	1960mm
Body Length (excluding hitch)	5558mm	6011mm	6410mm	6410mm	6410mm	6944mm	6944mm
Tyre Sizes	195/70R15	195/70R15	195/70R15	195/70R15	195/70R15	185/65R14	185/65R14
Awing Dimension	9443mm	10032mm	10230mm	10230mm	10230mm	10763mm	10763mm
Tyre Pressure	60psi	60psi	60psi	60psi	60psi	40psi	40psi
MRCO	1289kg	1348kg	1430kg	1423kg	1439kg	1566kg	1596kg
MTPLM	1415kg	1500kg	1600kg	1600kg	1600kg	1725kg	1755kg
Opt Equipment Payload	0kg	0kg	0kg	0kg	0kg	0kg	0kg
Total User Payload	126kg	150kg	154kg	154kg	154kg	159kg	159kg
Max Static Load on the Coupling Head	100kg	100kg	100kg	100kg	100kg	120kg	120kg
Wheel Torque	130N	130N	130N	130N	130N	130N	130N
Gas Locker	6kg x2	6kg x2	6kg x2	6kg x2	6kg x2	6kg x2	6kg x2

11th Year Service				
12th Year Service				
13th Year Service				
14th Year Service				
15th Year Service				



From the 2011 season the method of calculating the Mass in Running Order (MRO) and user payload figures has changed in order to bring it in line with European Vehicle Directives. Although the method of calculation has changed, the overall effect is that the amount of payload available to the customer has remained the same.

The following items are included in the MRO:

LPG - The mass of the recommended gas storage tank(s) when filled to 100% of the permissible maximum capacity. A mass of 10 kg per cylinder is assumed.

Fluids - The mass of the liquids normally remaining in the systems:

Water heater system = 100% of the manufacturer stated travelling capacity **(Bailey state 0%)**

Central heating system = 100% of the mass of fluid in the system

Freshwater = 100% of the manufacturer stated travelling capacity (you must travel with all water tanks empty) **(Bailey state 0%)**

Waste water holding tank = Empty

Toilet system flushing tank = 100% of the manufacturer stated travelling capacity **(Bailey state 0%)**

Toilet system holding tank = Empty

Essential fluids for the use of any other items of standard or factory fitted optional equipment = 100% of the manufacturer stated travelling capacity **(Bailey state 0%)**

Pitch Lead = 4kg for the low voltage connection cable

**Part of the MRO can be utilised as additional payload if you wish to travel without any of the above. The saved weight will = additional payload.**



Your caravan should be fully drained down prior to being in Transit. All fluid levels should be at 0% (excluding Glycol heating fluid contained within wet heating systems). The fluid travelling capacity of Bailey caravans is 0%. Any fluids contained within the caravan during transit should be deducted from your payload.

Typical masses consist of:

Kettle	0.5kg	Aquaroll (empty)	5kg
Bed Linen	6kg	Waste Bin	1kg
Crockery	5kg	Toilet Fluid	2.5 kg
Saucepans	3kg	Cutlery	2 kg
Wastemaster	6kg	Battery	25 kg



All dimensions are approximate due to slight variations in suspension heights, loading conditions and tyre pressures. Customers should verify the actual dimensions of their touring caravan before committing to anything that could be impacted by these dimensions. Any Retailer fit options will reduce the overall payload available to the user of the caravan. If you require additional payload it is possible to upgrade the MTPLM on some vehicles. Please contact your Bailey Caravan Retailer for more information. Awning sizes are ground to ground dimensions through the awning channel. Dimensions are issued as a guideline only.

Scheduled Service Type	Service Agent	Retailer Stamp	Technician's Name	Date
Retailer - Pre-Delivery Inspection				
1st Year Service (necessary to ensure warranty cover in the second year)				
2nd Year Service (necessary to ensure warranty cover in the third year)				
3rd Year Service (necessary to ensure warranty cover in the fourth year)				
4th Year Service (necessary to ensure warranty cover in the fifth year)				

## THE SERVICE MANUAL

5th Year Service (necessary to ensure warranty cover in the sixth year)					
6th Year Service					
7th Year Service					
8th Year Service					
9th Year Service					
10th Year Service					



Nearly 50 years ago, Bailey Owners Club was built on a foundation of friendship, fun and freedom.

The Club is run by and for members and is dedicated to the hobby of rallying with Bailey caravans and motorhomes.

Rallies are held across the UK, with a diverse range of activities suitable for all ages. Biennially Bailey open the factory exclusively for Bailey Owners Club members.

The Club fundraises for a range of charities throughout the year.

It couldn't be easier to join - simply go to [www.baileyownersclub.org](http://www.baileyownersclub.org) for details on how to become a member.









# Caravan Service Manual

October 2022

